

Learning and Information Services
Adsetts Centre, City Campus
Sheffield S1 1WD

27410

102 105 852 1

Sheffield Hallam University
Learning and Information Services
Adsetts Centre, City Campus
Sheffield S1 1WD

REFERENCE

ProQuest Number: 10700909

All rights reserved

INFORMATION TO ALL USERS

The quality of this reproduction is dependent upon the quality of the copy submitted.

In the unlikely event that the author did not send a complete manuscript and there are missing pages, these will be noted. Also, if material had to be removed, a note will indicate the deletion.



ProQuest 10700909

Published by ProQuest LLC (2017). Copyright of the Dissertation is held by the Author.

All rights reserved.

This work is protected against unauthorized copying under Title 17, United States Code
Microform Edition © ProQuest LLC.

ProQuest LLC.
789 East Eisenhower Parkway
P.O. Box 1346
Ann Arbor, MI 48106 – 1346

Cost Benefit Analysis of Computer Aided Engineering Implementation in
Bespoke Engineering Business

Karthik Ramakrishnan

A thesis submitted in partial fulfilment of the requirements of
Sheffield Hallam University
for the degree of Master of Philosophy

December 2012

Collaborating Organization: Joseph Rhodes Limited, Wakefield

PREFACE

This report presents the research, findings and recommendations resulting from a Knowledge Transfer Partnership project between Sheffield Hallam University and Joseph Rhodes Limited of Wakefield.

The idea of this particular study came from a customer presentation given by Joseph Rhodes Limited, Wakefield in 2006. The company lost its marketing opportunity for an order worth about £3 million to the competitor by not having a 3D visualisation and/or animation of its product. This made the company realise how important is advanced Computer Aided Engineering (CAE) to their future business.

A dedicated period of two years from June 2007 to June 2009 was allocated to fulfill the company's requirements with £56K funding from the UK DTI to the main objective which was to implement CAE techniques such as 3D modeling, finite element analysis, dynamic simulation, 3D animation and assess the costs and benefits achieved.

This report and the project's associated research work, provide a wealth of knowledge to the reader about the CAE implementation in a bespoke engineering business and the usage of different techniques available in the market with respect to cost related benefits. Report appendices include the proof of CAE influence such as customer satisfaction letter, company catalogues, poster presentations and 3D drawings for the business before and after the project.

ABSTRACT

Advanced Computer Aided Engineering (CAE) is a field that expands continuously, concurrently with technology growth. Exceptional benefits are available by implementing the techniques in the business activities. Design capability is the biggest asset to any engineering organisation and it is more important to maintain and update constantly. It is evident that during 1990 to 2010, the pace of technology growth reached its peak value and contributes to rapidly improving business growth patterns. Despite many limitations, it is interesting to see a bespoke engineering firm improve in performance and their benefits coming from the implementation of these advanced CAE techniques.

The thesis describes a two year partnership project between Sheffield Hallam University and Joseph Rhodes Limited, Wakefield in which 3Dimensional Computer Aided Design (CAD) modelling, dynamic simulation, Finite Element Analysis (FEA) and 3D CAD animation were applied to four company machines i.e. rubber die press, knuckle joint press, HME Coining press and clay extrusion machine to enhance both pre- and post order processes. Direct cost savings of £114,000 were achieved due to savings in designer's time and materials for major components as a consequence of improved stress analysis.

The project transformed the company's traditional method of 2D drawing methods to 3D methods with massive improvement in design standards. It also helps the designers to develop innovative design ideas with greater confidence and reliability. In addition to direct savings, improvements in tendering and quotation documentation due to 3D CAD were instrumental in increasing the overall company turnover by 300% from £7 million in 2007 to £21 million in 2010 with net profit averaged about £3 million. On conclusion of the project 6 designers were regularly using advanced CAE tools and techniques.

ACKNOWLEDGEMENTS

This will be my best opportunity to record my journey in Knowledge Transfer Partnership project between Sheffield Hallam University and Joseph Rhodes Limited. This particular period is the best part of my life, as I have personally noticed my confidence level increased.

I would like to say a special thanks to Professors Graham Cockerham and Dr. Syed Hasan for their wise support and exceptional patient during the Knowledge Transfer Project and in my thesis writing. I have learnt so many things technically and personally from the day one I met them and still learning. Without them this thesis would not be fulfilled.

I am extremely grateful to the board of directors at Joseph Rhodes Limited Mr. Ian Ridgway (Chairman), Mr. Mark Ridgway (Managing Director), Mr. Barry Richardson (Sales Director) and Mr. Alistair Nichol (Finance Director) for giving me a wonderful platform like KTP in my career and supporting me throughout my research activities.

I also like to thank my mentor Mr. Peter Anderton (Technical Director, Joseph Rhodes Limited) for teaching details of mechanical engineering concepts and guiding me with some practical examples in day to day activities. The lessons learnt from working with him direct me towards a clear career path.

I also like to thank my grandfather, mom and uncle for supporting me all these days to complete the thesis. Without their support, I won't able to cross this stage in my career and in life.

Finally, I must convey a special thanks to my wife for the patience shown in taking care of proof reading numerous drafts of the thesis and corrected my language and mistakes.

CONTENTS

Preface	
Abstract	
Acknowledgements	
PREFACE	i
ABSTRACT	ii
Contents.....	iv
CHAPTER 1 – INTRODUCTION.....	1
1.1 Introduction	1
1.2 Research Aim	1
1.3 Research Outline	1
1.4 Research Value.....	3
1.5 Research Activities.....	4
1.6 Knowledge Transfer Partnership.....	4
1.7 Thesis Synopsis by Chapter	7
CHAPTER 2 – DESIGN PROCESS.....	9
2.1 Introduction	9
2.2 Design.....	9
2.3 Engineering Design	10
2.4 Design Criteria	11
2.5 Design Process / Cycle.....	11
2.6 Design Evaluation	16
2.7 Design Standards.....	16
2.8 Conclusion.....	18
CHAPTER 3 – FINANCIAL PROCESS (CAE).....	19
3.1 Introduction	19
3.2 Investment Appraisal.....	19
3.3 Investment Appraisal Criteria	19

3.4 Investment Appraisal Methods.....	20
3.5 Conclusion.....	27
CHAPTER 4 – COMPUTER AIDED ENGINEERING	28
4.1 Introduction	28
4.2 Computer Aided Engineering (CAE).....	28
4.3 CAE Advantages	29
4.4 CAE Application	30
4.4.3 Computer Aided Animation	36
4.5 Selection of CAE Software	37
4.6 Conclusion.....	40
CHAPTER 5 – DESIGN OF RUBBER DIE PRESS	42
5.1 Introduction	42
5.2 Background of Rubber Die Press	42
5.3 Principle of Operation	46
5.4 Types of Rubber Die Press.....	47
5.5 10,600 Tonne Rubber Die Press.....	48
5.6 Development of Rubber Die Press.....	49
5.7 Cost Matters	52
5.8 FEA of Rubber Die Press	56
5.9 MWP Awards	86
6.0 Conclusion.....	87
CHAPTER 6 –DESIGN OF KNUCKLE JOINT PRESS AND MINTING PRESS	89
5.9 Introduction	89
6.2 Knuckle Joint Press (or) Horizontal Impact Knuckle Joint Press	91
6.3 Her Majesty Elizabeth Minting (HME) Press	95
6.4 Business Need	98
6.5 Dynamic Simulation (DS).....	99
6.6 Sample Stress Calculation – HME Minting Press.....	108

6.7 Benefits Achieved (Time and Cost)	115
6.8 Conclusion.....	116
CHAPTER 7 – DESIGN OF CENTEX EXTRUDER.....	118
7.1 Introduction	118
7.2 Extruder	118
7.3 2D to 3D CAD Modelling	120
7.4 Development of Centex Extruder.....	122
7.5 Conclusion.....	123
CHAPTER 8 - DISCUSSION AND CONCLUSION	124
8.1 Discussion	124
8.2 Conclusion.....	126
References:	128
Appendix -1	133
Appendix -2.....	134
Appendix -3.....	135
Appendix - 4.....	136

List of Figures

Figure 1: KTP Structure	5
Figure 2: Group Rhodes Structure (Rhodes, 2009)	6
Figure 3: The traditional and familiar ‘inventor’s’ approach to design: (Childs, 1998)	10
Figure 4: Typical design process vs. One-off design process	15
Figure 5: Rate of Return	20
Figure 6: Internal Rate of Return	24
Figure 7: Computer Aided Engineering – Application	30
Figure 8: Major Functional Elements of CAD System: (Hsu and Sinha, 1991)	32
Figure 9: Rubber Die Press (1965 and 2008) - John Shaw and Joseph Rhodes Limited	42
Figure 10: Guerin Process (Technology, 2005)	44
Figure 11: Verson - Wheelon Process (Technology, 2005)	45
Figure 12: Marform Process (Technology, 2005)	45
Figure 13: Principle of Operation - Loading	46
Figure 14: Principle of Operation - Forming	46
Figure 15: Principle of Operation - Blank holder Effect	47
Figure 16: Principle of Operation - High Pressure Calibraion	47
Figure 17: Testing of 10600 Ton Rubber Die Press	48
Figure 18: On site - 10600 Ton Rubber Die Press	49
Figure 19: Rubber Die Press - 3D CAD	53
Figure 20: Rubber Die Press - Animation	54
Figure 21: Cylinder Dimensions	55
Figure 22: Rubber Die Press- Hydraulic cylinder	56
Figure 23: Hydraulic cylinder - Geometry and Mesh	59
Figure 24: Hydraulic cylinder - Loads and Constraints	61
Figure 25: Hydraulic cylinder - Equivalent Stress	62

Figure 26: Hydraulic cylinder - Max. Principle Stress.....	62
Figure 27: Hydraulic cylinder - Min. Principle Stress	63
Figure 28: Hydraulic cylinder - Deformation.....	63
Figure 29: Hydraulic cylinder - Safety Factor.....	64
Figure 30: Rubber Die Press - Press frame	65
Figure 31: Frame plate - Geometry and Mesh	66
Figure 32: Frame plate - Equivalent Stress	69
Figure 33: Frame plate - Max. Principle Stress.....	70
Figure 34: Frame plate - Min. Principle Stress	71
Figure 35: Frame plate - Deformation.....	72
Figure 36: Frame plate - Safety Factor.....	73
Figure 37: Rubber Die Press - Pad holder with backing plate	74
Figure 38: Pad holder - Load schematics	75
Figure 39: Pad holder - Equivalent Stress -View 1	78
Figure 40: Pad holder - Equivalent Stress -View 2	78
Figure 41: Pad holder - Deformation	79
Figure 42: Rubber Die Press - Moving table.....	79
Figure 43: Moving Table - Load schematics.....	82
Figure 44: Moving table: Equivalent Stress - View 1	83
Figure 45: Moving table - Load distribution curve across piston circumference	84
Figure 46: Moving table: Equivalent Stress - View 2	84
Figure 47: Moving table - Displacement distribution curve across piston circumference	85
Figure 48: Typical Knuckle Joint Press	89
Figure 49: Time and Displacement Diagram	90
Figure 50: Knuckle Joint Press – Products.....	91

Figure 51: 3D CAD - Horizontal Knuckle Joint Press.....	92
Figure 52: View 1 - Typical Joseph Rhodes Knuckle Joint Press.....	93
Figure 53: View 2 - Typical Joseph Rhodes Knuckle Joint Press.....	93
Figure 54: KJ Press - Linkage Assembly	94
Figure 55: Knuckle Joint Press - Link configuration	94
Figure 56: View 1: HME Minting Press: Joseph Rhodes Limited.....	96
Figure 57: View 2: HME Minting Press: Joseph Rhodes Limited.....	96
Figure 58: 3D CAD - HME Minting Press.....	97
Figure 59: Typical Dynamic Simulation Workflow: Joseph Rhodes Limited.....	101
Figure 60: KJ Balancing - Vertical Out of Balance (Theoretical)	103
Figure 61: KJ Balancing - Vertical Out of Balance (Dynamic Simulation)	103
Figure 62: Horizontal Out of Balance (Theoretical)	104
Figure 63: KJ Balancing - Horizontal Out of Balance (Dynamic Simulation)	104
Figure 64: KJ Balancing - Total Inertial Force (Theoretical)	105
Figure 65: KJ Balancing - Total Inertial Force (Dynamic Simulation)	105
Figure 66: Linkage Assembly - HME Minting Press.....	109
Figure 67: Load Faces	111
Figure 68: Constraints	112
Figure 69: Von-Mises Stress	113
Figure 70: 1st Principal Stress.....	113
Figure 71: 3rd Principal Stress	114
Figure 72: Displacement	114
Figure 73: Safety Factor	115
Figure 74: 3D CAD - Craven Fawcett - Centex Extruder.....	119
Figure 75: Extruder Worms.....	121

Figure 76: Pressure and Velocity profiles during extrusion [Picture Courtesy of Saravana Kumar Kandasamy].....	123
Figure 77: Velocity and Temperature profiles during steam injection in autoclaves [Picture Courtesy of Saravana Kumar Kandasamy].....	123
Figure 78: KTP AWARDS.....	126

List of Tables

Table 1: Joseph Rhodes Design Standards (Roy, 2006)	17
Table 2: Sample spreadsheet from Expert CAD Management: The complete guide (Green, 2007).....	21
Table 3: Cost comparison between Inventor and Solid works done in 2007 at Joseph Rhodes. (Ramakrishnan, 2007)	40
Table 4: Cost Saving in terms of Time and Material - Before and After CAE Implementation.....	50
Table 5: Time Plan - CAE activities (Rubber Die Press).....	51
Table 6: Hydraulic Cylinder Statistics	58
Table 7: Hydraulic cylinder - Material Properties: Cast Steel	59
Table 8: Hydraulic cylinder - Loads and Constraint Definitions	60
Table 9: Hydraulic cylinder - Constraint Reaction	60
Table 10: Hydraulic cylinder - Structural Results.....	61
Table 11: Frame Plate Statistics	67
Table 12: Frame plate - Material Properties: EN 50 B.....	67
Table 13: Frame plate - Load and Constraint definition	68
Table 14: Frame plate - Constraint Reaction.....	68
Table 15: Frame plate - Structural Results.....	68
Table 16: Pad holder Statistics	76
Table 17: Pad holder - Material Properties: EN 50B	76
Table 18: Pad holder - Structural Results.....	77
Table 19: Moving table Statistics.....	81
Table 20: Pad holder - Material Properties: EN 50B	81
Table 21: Moving Table: Boundary Conditions.....	83
Table 22: Moving Table - Structural Results	83

Table 23: Benefits of CAE Application - Rubber Die Press.....	88
Table 24: Result Comparison.....	106
Table 25: Material Savings - Designing KJ Press.....	107
Table 26: Time Plan and Saving - Designing KJ Press.....	108
Table 27: Physical Properties.....	109
Table 28: Analysis Settings.....	110
Table 29: Advanced Settings.....	110
Table 30: Material Properties.....	110
Table 31: Boundary Conditions.....	111
Table 32: Reaction Force and Moment on Constraints.....	111
Table 33: Result Summary.....	112
Table 34: Benefits of CAE Application - Knuckle Joint Press and HME Minting Press	117
Table 35: Extruder - Sub-Contract cost Vs Actual Cost.....	119
Table 36: Cost Benefits - Joseph Rhodes.....	125

CHAPTER 1 – INTRODUCTION

1.1 Introduction

The whole investigation is based on the development work carried out as a part of a KTP project between Sheffield Hallam University and Joseph Rhodes Limited. The main goal of the project was to service the growing market of bespoke engineering design by introducing advanced Computer Aided Engineering (CAE) techniques and to support new product development with minimum lead-time and cost.

Examples are taken from Joseph Rhodes Limited, to investigate cost effective ways and uses for implementing CAE techniques in a bespoke engineering business. The works furnished in this chapter detail the research aim, research objectives, and outlines the study and the partners involved in the project. In addition, use of advanced techniques and its needs to the current bespoke engineering business is explained with an example.

1.2 Research Aim

The aim of the research was to evaluate the cost effectiveness of the application of advanced CAE techniques in a design to order manufacturing business.

1.3 Research Outline

Since the arrival of CAE on the engineering scene in the mid-1980s, there has been much speculation regarding the benefits to be gained from the use of Computer Aided Engineering Methods.

Early case study work by Wainright, (1995) clearly identified a minimum of 130% of design lead time savings in manufacturing industries, achieved by changing traditional design processes to advanced processes via a case study conducted within a medium-sized and multi-product batch manufacturing company. At the same time 160% savings were made from moving traditional design processes to modified advanced processes.

This shows the benefits for design by using CAD and its vital role in achieving those benefits. He also states only product design determines the market uncertainty and complexity of the product. Therefore, it is evident that by using CAD system, a considerable amount of design lead time (i.e., cost) can be saved and maximum benefits can be achieved in manufacturing industries.

Although a survey conducted with 115 companies in 1990's by Short, (2001), concluded that training and other human factor limitations were preventing most of the companies in the survey from achieving their target benefits, he implies, companies from industries such as glass ware, hand tools, roofing construction, masonry grills and scientific instrumentation have indicated problems stemming from a lack of management support for use of the system, communication problems and lack of direction from senior staff. His survey also indicated that the effective utilisation of both 3D and 2D CAD systems were only in large scale industries.

Around the same time, Maylor, (1997) investigated the key factors in successful new product development (NPD) and the application of tools and techniques in an organisation. His findings towards new product development and its intensity of use (IOU) within a firm implied that computer-aided tools only has 52.8% IOU , whereas project management is known to be most important with 87.2% followed by design for manufacture with 72%. He concluded that CAD/CAM technology is not in itself sufficient for a successful NPD strategy; there are many other factors like quality function deployment, project management and implementation issues which are needed for successful NPD.

Similar conclusions were drawn by Tantoush, et al., (2001) by a case study approach from two UK medium sized manufacturing companies with a turnover of £15 to £25 million, suggesting that many of the problems in adopting CAD/CAM are political within organizations seeking to gain benefit from CAD/CAM systems.

Recently, there appears to have been a step-change in the benefits achieved by companies, as evidenced from an Aberdeen Research Group, (2006) which arose from companies which migrated from 2D systems to 3D modelling and onto finite element analysis (FEA). Replacing physical prototypes with virtual prototypes is one of the main benefits for the people who migrated. For example, manufactures of complex products that have migrated from 2D to 3D had released their products an average of 41 days earlier than their competitor with average savings of \$15,000, due to fewer prototypes. This was based upon surveys in the automotive and related industries where mass production is common and costs for CAD usage can be amortized over large volumes of product sales. For companies involved in one-off large scale projects, these benefits may not be available and it would be generally beneficial to a wider audience to be able to model the economic benefits for these types of company.

Joseph Rhodes Limited is a very good example with orders for single pieces of equipment well in excess of £1 million and hundreds of man-hours of design time required. Recent studies by Reid, (2007) have concluded that knowledge management in these types of companies' present uniquely different problems to those in mass production organization, which is likely to be the same for advanced CAE.

1.4 Research Value

This research shows the extent to which Joseph Rhodes selection and implementation into the business of CAE techniques such as 3D CAD, FEA and 3D animation has benefited productivity as well as cost effectiveness. The complete research findings would be helpful to transform a bespoke engineering business from its old traditional system to modern computer-aided-techniques. These findings are explained through market analysis and some case study examples from Joseph Rhodes Limited, Wakefield, UK.

1.5 Research Activities

The work program proceeded as follows:

1. Review company requirements for the application of 3D CAD modelling and FEA.
2. Identify suitable systems to satisfy requirements.
3. Use advanced CAD/FEA to support company design activities and designers across a number of projects
4. Monitor time and costs incurred when using advanced CAD/FEA and compare with non-CAD/FEA costs
5. Model costs and benefits from using advanced CAD/FEA in the bespoke manufacturing environment.

1.6 Knowledge Transfer Partnership

Knowledge Transfer Partnership (KTP) is a government funded programme to encourage relationships between universities and companies (Figure 1), was established in 1975 and is renowned as one of the world's leading knowledge transfer mechanisms. The main aim of the KTP is to facilitate transfer of knowledge and technology through university partner and multiply the company skills. As a start the company approaches local universities and submits their proposals as a structured project. On the success of the application, the company contribute 40-67 % of the total project cost and the remainder is contributed by the government. KTP between Sheffield Hallam University and Joseph Rhodes, Wakefield was formed to introduce a project to implement advanced CAE techniques and innovative design methods.

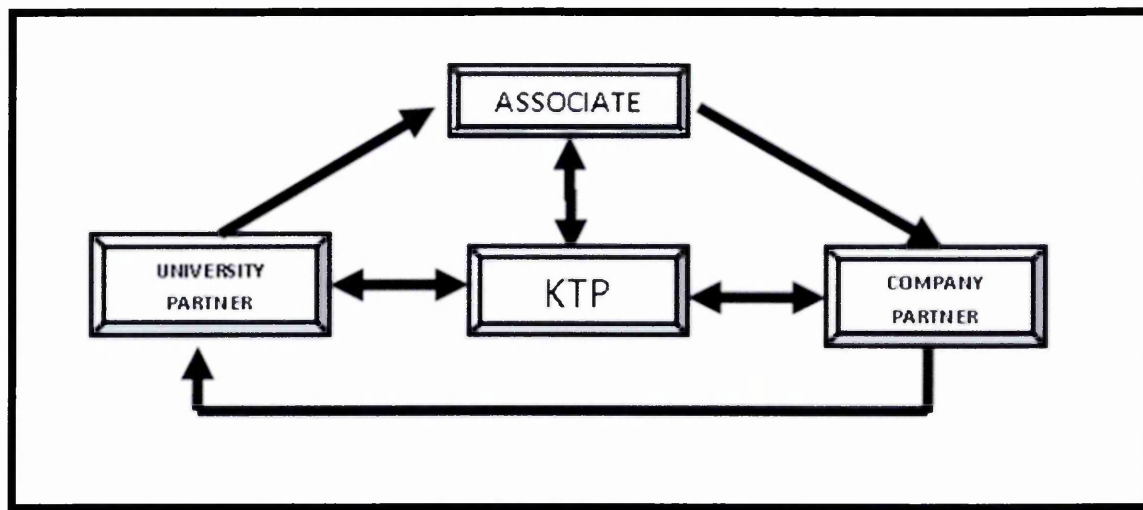

Figure 1: KTP Structure

1.6.1 Company- Joseph Rhodes Limited

Joseph Rhodes Limited was founded in 1824 and is one of Europe's largest manufacturers of metal forming machinery and specialises in bespoke mechanical and hydraulic pressing machines.

The company is renowned for supplying high quality, state of the art machinery. Standard models of Mechanical and Hydraulic presses, offered in both Open Front and Double Sided designs sit alongside highly specialized machinery in the Rhodes portfolio. From 2003 to 2011, the company has acquired three businesses operating in different market sectors. These business strands retain some of their former identities for branding purpose as shown in Figure 2, and are presented to the outside world as Rhodes Interform - (Aerospace metalworking equipment), Craven Fawcett Limited (Clay preparation and concrete working equipment) and Beauford Engineers (Structures for sub-sea oil exploration). The whole businesses are named as Group Rhodes and operate from an eight acre single site in Wakefield, UK. The company had 180 employees with an average turnover of around £7 million a year in 2007.

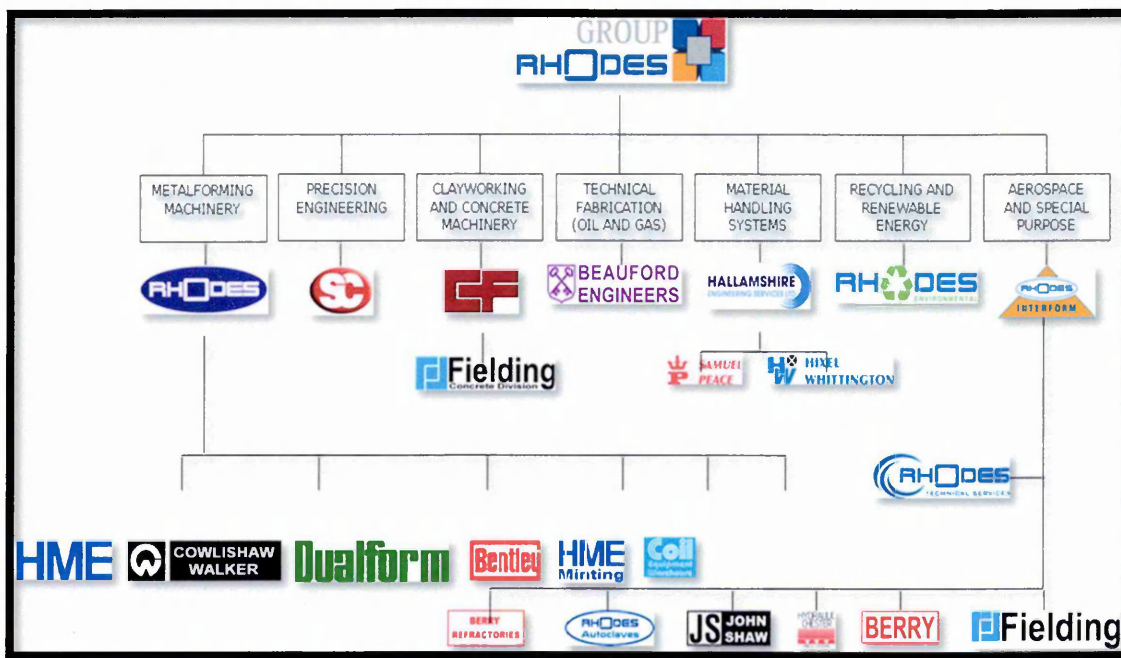

Figure 2: Group Rhodes Structure (Rhodes, 2009)

1.6.2 Sheffield Hallam University

Sheffield Hallam University is one of the UK's most progressive and innovative universities (University, 2010). The university has specialized expertise in e-learning and offers a variety of distance learning courses. The main vision of the university is to be renowned as forward thinking, enterprising and business engaged. The university is situated in the heart of the Sheffield and its suburbs with world class resources and research facilities.

1.6.3 Partnership Strategy – Example

A significant fraction of company turnover is based on bespoke design of high performance capital equipment. Even though Joseph Rhodes Limited has a strong reputation for high quality design, the modern commercial environment demands concept designs to be produced with some evidence of machine performance to prove its reliability, stability, and performance. Prior to the KTP programme, the company design department had predominately completed the designs using manual calculation

with 2D drafting. This approach can result in over-conservative designs, which are uneconomical and have long lead times in the proposal and final design stages. To change the current situation and to maximize order winning, the company is keen to explore the implementation of in-house advanced CAE facilities. By implementing these facilities, the company can keep a strong position among the competitors and maintain themselves in the current trend.

1.7 Thesis Synopsis by Chapter

CHAPTER 1-Introduction

This chapter explains the Knowledge Transfer Partnership between Sheffield Hallam University and Joseph Rhodes Limited, which helps to contextualise this research. A brief account of CAE techniques and typical advantages are included. The main aim of chapter 1 is to give a clear view of the research outline, aim and the activities undertaken.

CHAPTER 2- Design

This chapter defines the design process in a typical manufacturing environment. A typical comparison is also discussed between tradition design process system and advanced design system following CAE implementation.

CHAPTER 3- Financial Process (CAE)

Finance is one of the important aspect in a business. This chapter provides a small literature review on investment appraisal methods associated with implementation of CAE applications inside the business.

CHAPTER 4- Computer Aided Engineering (CAE)

This chapter gives a complete view of the CAE family and its application in a bespoke engineering business. CAD management and selection of CAD software is briefly explained for an engineering business dealing in one-off large scale projects.

CHAPTER 5- Design of Rubber Die Press

This chapter describes the background and origins of the rubber die press and its design process. The chapter focuses on problems developed in manufacturing a one-off large project and how CAE solid modelling and FEA applications were beneficial to solve and develop a commercial rubber die press and its components.

CHAPTER 6- Design of Knuckle Joint Press and HME Minting Press

One of the Advanced CAE technique called Dynamic Simulation is explained in detail with the help of an analysis carried out for a Knuckle Joint Press and Her Majesty Elizabeth Minting Press. Sample dynamic simulation calculations are included to illustrate how out of balance forces are balanced, followed by a full process chart explaining where exactly dynamic simulation fits in the design process.

CHAPTER 7- Design of Centex Extruder

The main theme explained in this chapter is about cost benefits and its implication in implementing CAE techniques in a bespoke engineering business. One particular group of machines from Joseph Rhodes was taken into account for the detail study. The study involves complete 3D modelling with animation and determines the time and cost required to do it in-house. At the same time the calculated cost and time was compared to a supplier quotation, to identify the benefits.

CHAPTER 8- Discussion and Conclusion

Details the overall benefits of the CAE implementation and outcome of the Knowledge Partnership (KTP), project. Also gives an overview of the KTP Awards and winning partnership (Joseph Rhodes Limited and Sheffield Hallam University) benefits.

CHAPTER 2 – DESIGN PROCESS

2.1 Introduction

A simple definition of design is an ‘activity which solves problems’ Braha and Maimon, (1998) concludes in their chapter ‘Design as scientific problem – solving’ as Design begins with the acknowledgement of needs and dissatisfaction with the current state of affairs and realization that some action must be taken place in order to solve the problem. In a bespoke engineering organisation the design activity starts from creating concept sketches (pre-order stage) to the final manufacturing and assembling of the product. This particular chapter describes the nature of the company design process and the associated activities for an engineering business with one-off large scale projects. Also a typical design cycle for Joseph Rhodes and its associated cost and time are explained. It is concluded with a detail cost analysis of the current system compared to the CAE techniques implemented system.

2.2 Design

Design is an essential creative stage in a product development cycle. It generally originates when a need or requirement for the work arises in the marketplace. Childs, (1998) indicates the word design originates from the Latin word *designare*, meaning to designate or limit. He also states that mechanical design refers to the design of products and it can be engines, machines tools and precision instruments.

Bronikowski, (1986) defines design as creative ideas which are being converted into a finished product of some type. Design can be achieved through many stages like conception, visualization, calculation, analysis, often following standards and sometimes including optimisation. These stages are the major functional element of the design activity and without these elements, a good design cannot be generated. Sherwin,

(1982) and Childs, (1998) suggests it is difficult to break up the design stages as they are very much inter-linked to each other. However, they also mentioned that businesses need to find possible solution and evaluations of those solutions are the three basic steps of the traditional design activity to achieve the solution as shown in the Figure 3. Since the availability of the computer and its application, design has become more sophisticated for the designer by overcoming the traditional ways of working and saving time and money. All the key elements are achieved more accurately with less possibility of human errors. This achievement stands as a big milestone in the engineering business. As the technology develops, the need for the business to get more focused obtains, which in turn requires more powerful equipment to solve complex analytical problems.

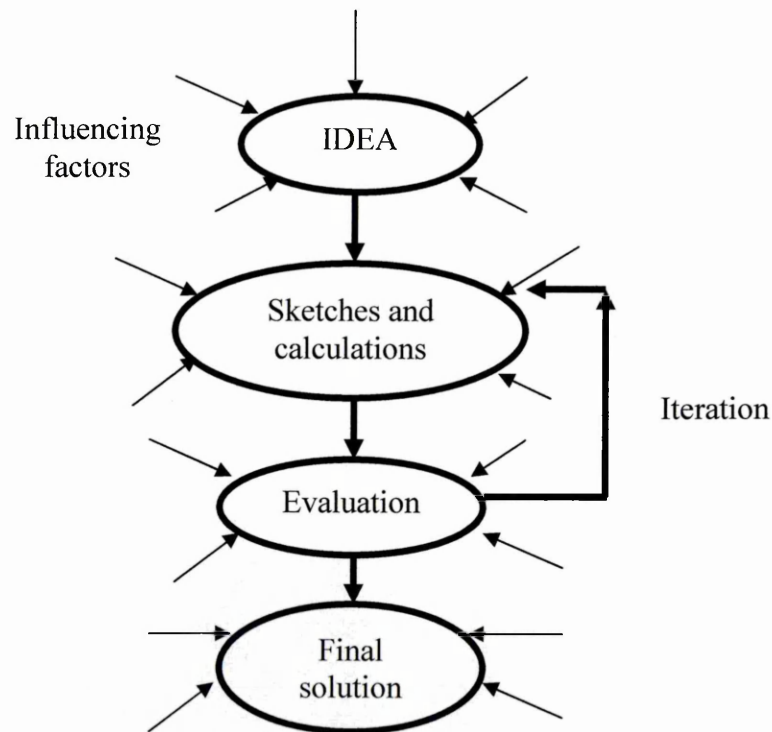

Figure 3: The traditional and familiar ‘inventor’s’ approach to design: (Childs, 1998)

2.3 Engineering Design

Design is the soul of the engineering sector. Parameswaran, (2004) defines design in engineering as a utilization of available resources which transforms abstract concepts

into discrete details with physical realisation. Eder and Hosnedl, (2007) describes the Design engineering as solving technical problems, finding suitable and preferably optimal solutions for the given task. Also, Engineering design is the field where all the study, experience and practice are applied together to produce a quality product.

2.4 Design Criteria

A design criterion defines performance and varies from product to product and industry to industry. As the thesis represents heavy duty machines and their components, the requirement criteria are very simple and design is an easy process based to a large extent on technical function. Eide, et al., (2001) states that cost is the only factor which is heavily weighted when looking after design criterion. However, it also depends on company needs whether it is going for a brand new design or re-design. Brand new design always have to go through the design process /cycle before being released. If re-design work is possible, then the design process is a more straight forward and cheaper task but still it has to be tested to the optimised condition.

2.5 Design Process / Cycle

Armstrong, (2008) describes, the design process is a course of actions used to define and solve problems. The process starts with the creation of detail product specification followed by design and implementation. The design process has remained the same over the past three to four decades but the technology governing the design grows faster at the same time.

Since this particular project is focused on one-off large scale productions, the process time is reduced by half with the help of advanced technologies in computers. The following describes each phase of the company design process.

2.5.1 Concept Sketch Phase

This is the first step in Joseph Rhodes process and is also called ‘check phase’. In early stages concept sketches are created by pencil and paper. This is the phase where all the ideas are generated and the product specification is reviewed for compliance. At least three to four concept sketches are needed to generate a more critical review and go through final approval. Computer generated concept sketches can make life easier and quicker. The generated sketches are then taken to an analysing cycle where the concept gets confirmed. 3D animation and all other computer graphics can be included to check the interaction of the products and to understand the system performance. After being critically analysed the concept sketch is then taken into an experimental phase where the sketch gets its original shape (product). Concept sketches always add more value to the design and the product nature.

2.5.2 Preliminary Design Phase

This entails a detailed study of the machine specifications to find the best solution from possible conceptual alternatives. This is classically described by Bronikowski, (1986) as a project consisting of designing, drafting, building samples and testing them. All the sketches from the concept are developed to a defined shape and structure. Then the shape (product) goes under critical analysis and reviews, where the product turns into its optimum shape before it passes to final manufacturing. Once the product is defined, it has to be tested for functionality, safety margins and design constraints.

2.5.3 Detail Design Phase

Immediately after the preliminary design, the detail design phase comes into force. This phase mainly involves creating manufacturing drawings and detailing the product by giving appropriate tolerances, using standard symbols, providing various sectional and

Isometric views. This gives the machinist a greater confidence and less error in manufacturing the product.. Therefore 2D drawings are used as the best way to provide a simple and clear view of the product to be manufactured. In Joseph Rhodes, the draftsman gathers the details from the preliminary design and checks the interference between the products. After thorough verification, dimensions and tolerances were made according to the British Standards and finally the drawing is catalogued with a unique Joseph Rhodes number.

2.5.4 Prototype Phase

This is the most exciting phase where the sketches or models are transformed into defined physical shape and is an extension of the experimental phase however Raymond Bronikowski, (1986)states that the prototype test will provide more comprehensive details about the product than the experimental phase. The prototype phase is where the product can be tested for its compatibility with other components. Costly mistakes in design are eradicated by re-designing at this stage. However this practice can be expensive and may be replaced to some extent by computer software applications, like CAE modelling and analysis, thus reducing the time and money consuming processes.

2.5.5 Testing

At this point, the product strengths and weaknesses are determined and validated against appropriate industry standards and also by taking account of appropriate equations for appropriate material. This will then provide an estimated life and reliability for the product. If the product fails the testing phase, then it is returned to the preliminary design phase for modifications. In the past within Joseph Rhodes, calculations were done theoretically on paper. However, as part of the KTP programme, it has been largely converted into analysis by the use of based computer programs. This will save

the company a considerable amount of time and money in redesign when testing identifies malfunctions and is particularly important for the company where complete machines are built in-house and subjected to acceptance trials.

2.5.6 Production and Assembly

This is the final phase of product development, where the product is ready for dispatch. Previously it is one of the longest phases in the process because of immature machines and more hands-on processing. These days, advanced machines are capable of producing faster, more accurate, highly reliable and fully automated processes. This increases the production efficiency to the greater extent which in turn increases the profit.

Figure 4 shows the difference between the typical batch design process and one-off design process. A typical batch design process will have the prototype phase which eliminates the errors in the design process before going to first line production. Then the product goes under another checking phase before going to second line production stage. But for the one-off design process typical of Joseph Rhodes' business, there are no prototypes or checking phase because of its unique and complex design. Therefore, in reality if there are any errors in design this will directly affect the production and assembly phase immensely.

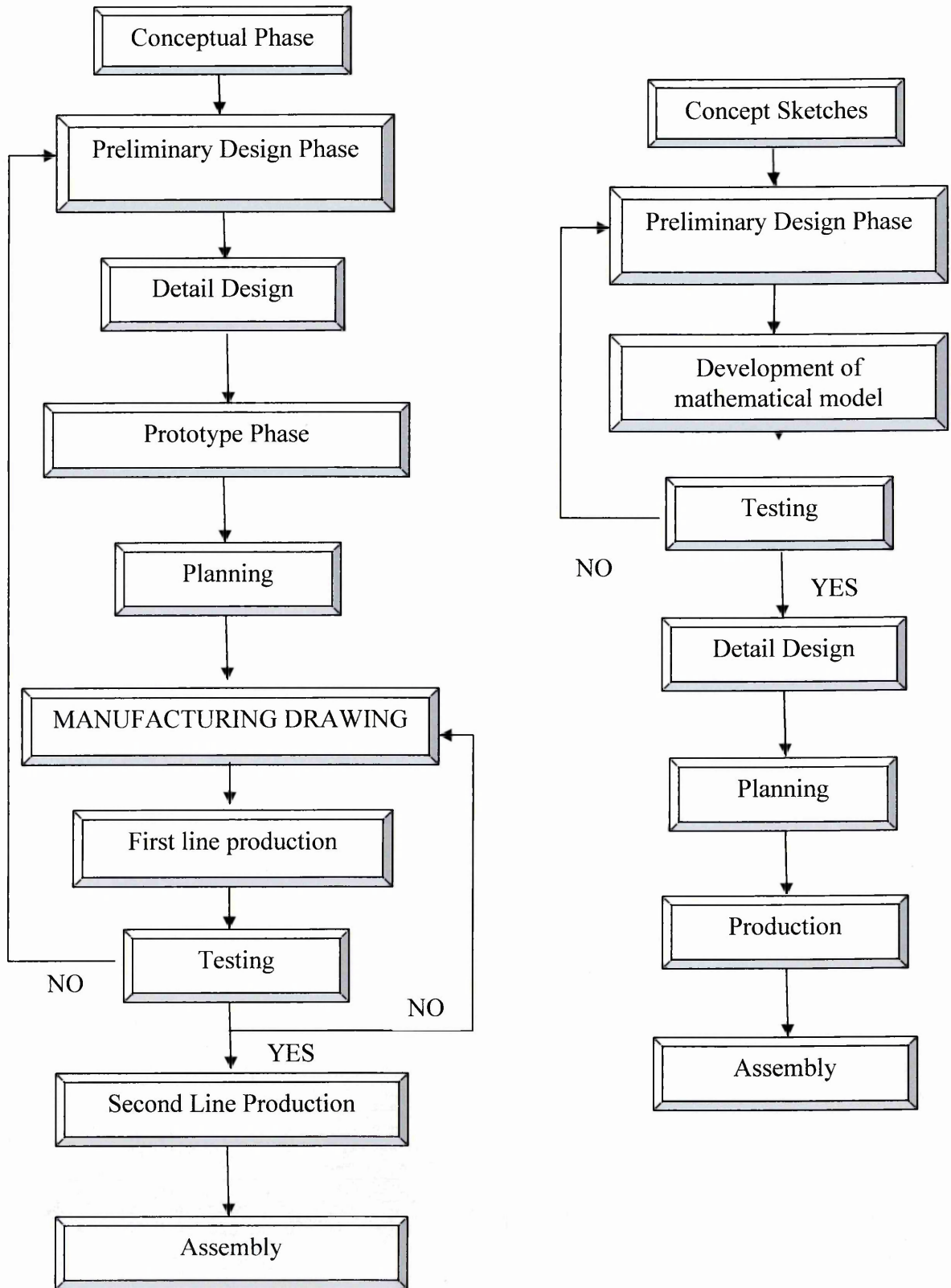

Figure 4: Typical design process vs. One-off design process

2.6 Design Evaluation

Design evaluation can either take place at the starting stage of the design as formulated or it can take part at the end of the design cycle as a summative process. Evaluation can be termed in different ways such as cost based, time based and technical calculation based. All the three terms are most popular among the design people because it helps to make decisions. In the case of calculation based, repeat analysis (theoretical or computational) with different case scenarios helps the designer to decide the best surroundings (constraint and load case) in the given parameter. Both time and cost based analyses are given high priority activity because it tends to reflect in the final cost estimation of the product. A huge difference in this activity, leads the business into a critical situation. Simon, (1975) points out mistakes in evaluation can be found by checking and re-checking the habit of the designer.

2.7 Design Standards

Dym and Little, (2004) defines the benefits of design standards as “standards explicitly articulate the best current engineering practices in routine or common design situations”. All the design activities should be carried out within the standards and within the limitations of the product. Design standards may vary from product to product and industry to industry. For example Joseph Rhodes Limited, Wakefield follows four different industry standards such as metal forming and hydraulic presses, sub-sea structure, clay working and waste management related British Standards to maintain health and safety and quality of the product. The following Table 1 are some of the examples of standards used to design machinery at Joseph Rhodes Limited.

Table 1: Joseph Rhodes Design Standards (Roy, 2006)

1	BS 8888:2002	Technical product documentation (TPD). Specification for defining, specifying and graphically representing products
2	BS ISO 128-20:1996	Technical drawings. General principles of presentation. Basic conventions for lines
3	BS ISO 128-21:1997	Technical drawings. General principles of presentation. Preparation of lines by CAD systems
4	BS ISO 128-22:1999	Technical drawings. General principles of presentation. Basic conventions and applications for leader lines and reference lines
5	BS ISO 128-24:1999	Technical drawings. General principles of presentation. Lines on mechanical engineering drawings Current 20 pgs.
6	BS ISO 406:1987	Technical drawings. Tolerancing of linear and angular dimensions.
7	BS4500/ BS EN20286	ISO Limits and Fits
8	BS EN ISO 4287:2000	Geometrical product specification (GPS). Surface texture. Profile method. Terms, definitions and surface texture parameters Current 40 pgs.
9	BS308 :Parts 1-Withdrawn	Engineering Drawing Practice : General Principles
10	BS308 :Parts 2-Withdrawn	Engineering Drawing Practice : Dimension and Tolerance
11	ISO9001(1994)	Quality Systems - specifications for design, development, production, installation and servicing.
12	BS 5760:Pt 0: 1993	Introductory guide to reliability
13	BS 7373:1998	Guide to the preparation of specifications
14	BS 5760:Pt 6: 1993	Guide to Fault Tree Analysis
15	BS EN 292 Pt 1 and Pt 2	Safety of Machinery Basic concepts , general principles for design

2.8 Conclusion

Design is the heart of a bespoke engineering business. As discussed in the above sections, every step in the design cycle starting from concept to manufacture is very important to the bespoke engineering business because any mismatch in the process and failure to perform to the standards will result in huge catastrophes. Therefore maintaining the principles of design and its activity is very important for a bespoke engineering business in order to achieve the target, being competitive in the market.

CHAPTER 3 – FINANCIAL PROCESS (CAE)

3.1 Introduction

Cost targets and control are very important in a bespoke business and the effectiveness of CAE purely depends on good practice and consumption. Based on the available information, a thorough investigation is required of the market and a preliminary estimation such as return on investment, sensitivity analysis and rate of return needs to be calculated in careful consideration.

3.2 Investment Appraisal

Investment in a project is an initial turning point which gives more power to the project by providing the necessary financial basis for an effective outcome. In such cases, a few strategies like rate of return, discounted cash flow payback period can be used for the detailed analysis in order to place the company in a strong position and to eliminate the financial risk involved. Also some strategic analyses need to be planned before commencing and appraising a project. In recent days, plenty of tools have become available to conduct these kinds of analysis effectively and efficiently. For an engineering business, the uses of these advanced techniques are required to survive and to get a strong lead in the current dynamic and competitive market.

3.3 Investment Appraisal Criteria

According to the editors Idowu and Louche, (2011) to appraise an investment project, the appraiser must have information about the following areas:

1. Cost of Investment
2. Estimated life cycle
3. Estimated cash inflows

4. Estimated residual value of the project at the end of its life if applicable
5. Cost of capital
6. Taxation implications of project
7. Inflation rates and effect on project
8. Degree of risk involved

By taking into account the above listed criteria, an appraiser can make an affirmative decision on the project. McCosker, (1996) also implies before making decision concerning investment in any projects, an organization needs to consider the above listed criteria. He further states, in order to assist with investments and minimize the risk of selecting a project with a low or negative rate of return, it is essential for an organization to have an awareness of the main financial evaluation techniques used to evaluate projects.

3.4 Investment Appraisal Methods

3.4.1 Rate of Return (ROR)

As a well known factor in finance, **rate of return (ROR)**, also known as **return on investment (ROI)**, is the money ratio gained or lost to the amount of money invested. The amount of money invested refers to the asset, capital, principal, or the cost basis of the investment to the business and often is proportional to the risk associated with the project as shown in Figure 5. Also Green, (2007) indicates most analyst/investors points

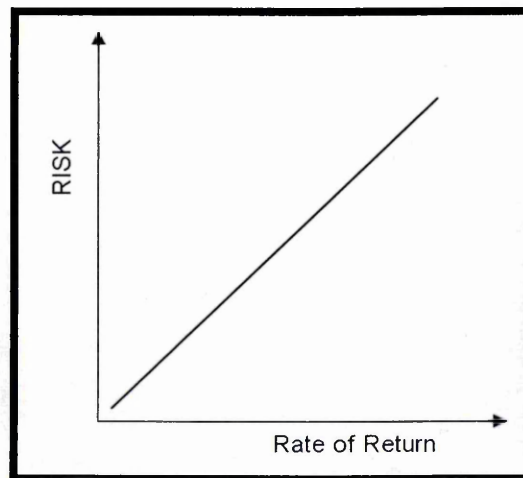

Figure 5: Rate of Return

out the golden economic rule and the sample spreadsheet presented in Table 2. (Higher the rate of return is required to be charged for higher risk and vice versa).

$$\text{Rate of Return} = ((\text{Return} - \text{Capital}) / \text{Capital}) \times 100\%$$

ROR is usually expressed in terms of percentage towards contribution and is measured with metrics like profitability. The ROR is directly proportional to the risk involved, therefore the higher the contribution, the higher the profit. Also according to Solutionmatrix.com, (2010) most forms of ROR compare investment returns and cost by constructing a ratio, or percentage. In most ROR methods, if ROR is ratio greater than 0 then the investment returns more than its costs.

Table 2: Sample spreadsheet from Expert CAD Management: The complete guide (Green, 2007)

Cost Saving Idea	Time Saved (hrs/month)	Labour rate (£ /hr)	Annual Savings (£)	Costs	ROI (%)	Payback (Yrs)
Replace manual symbol insertion with automated, menu driven routines.	50	21.5	12900.00	4750.00	272	0.37
Eliminate problems with initial drawing setups by conducting custom training	20	21.5	15160.00	2000.00	258	0.39
Automate file cleanup and export via implementation of Visual Basic routines	70	21.5	18060.00	7200.00	251	0.40
Make work harder by implementing bureaucratic processes that make users undertake more steps to get the same task done.	-20	21.5	15160.00	2000.00	-258	-0.39
This is the cost saving idea	This is the time savings you can achieve each month by putting your cost saving idea in to effect. Don't forget to compute saved hours for all people who's time you actually save!	This value is simply the labor cost of the person who's time your saving. Therefore, if you will save drafting time with your cost saving idea you should put the labor rate for a drafter in this column.	This value is simply the time savings of your idea multiplied by the labor rate and adjusted for an entire year.	This is the total cost of implementing your idea. Don't forget software, hardware, warranties, training time, subscriptions, etc, when you compute the total cost.	Savings divided by costs displayed as a percentage. The higher the number the better.	The number of years it'll take for your idea to pay for itself. The lower the number the better.

Drawbacks of ROR

Spiewak and Weiss, (1954) states that ROR does not take into account the cash flow timing and the calculation is only based on accounting concepts. To add to this, Shim et al. imply ROR by itself says nothing about the risk of an investment, It simply shows how returns are compared to cost invested. They further go on to state that ROR does not indicate future cash flow and it assumes static indicators. Therefore, ROR method should be utilized along with the other investment appraisal methods, in order to receive a better outline of the investment.

3.4.2 Discounted Cash Flow (DCF)

Discounted cash flow (DCF) is one of the simplest methods used in investment appraisal. The DCF shows how quickly (time) the cash flows arising in the project is equal to the initial investment.

Bolt, (2005) states that DCF is a tool that is used to decide:

1. Which of several possible projects is the most financially appealing.
2. Whether a proposed capital project will be worthwhile.

He also states that the essence of investment is that money is spent now to produce benefits in the future; assuming those benefits can be quantified in monetary terms, we need to ask what their present value worth is. In order to calculate this, the net cash flow that the project will generate over each year of its life and convert this to a present day value. This will then add up to get the Net Present Value (NPV). Twiss, (1926) says “Money has a time dimension and it cannot be ignored”. In addition, he added, DCF provides a valid basis of comparing projects with similar time frames.

By looking at different views, DCF is a tool which only depends on time (Interest and Discount rates) and it is the only analysis that can predict accurately future cash flows.

It is also the only model that it can be separately used in evaluating project and is more flexible in adapting two to three different projects simultaneously.

On the other hand Wright, (1973) pointed out, DCF cannot be used as a sole criterion where projects with wide different time frames are compared.

3.4.3 Net Present Value (NPV)

Net Present Value (NPV) is the method which mainly deals with the duration of the project, as in this method, the value of t money changes with respect to time i.e., what is the money value worth today in comparison to the money value worth this time next year

DeFusco, et al., (2007) outline the following simple rules to calculate NPV of a project

1. Identify all the cash flow associated with the investment (both inflows and outflows).
2. Determine appropriate discount rate.
3. Using the discount rate, find the present value of each cash flow.
4. Sum up all the present values as NPV
5. Apply NPV rule: if the NPV is positive, an investor should undertake it and vice versa.

Biz/ed provides the following NPV formula:

$$\text{Future Value}$$

$$\text{PV} = \frac{\text{Future Value}}{(1 + i)^n}$$

Where i = interest rate

n = number of years

- The PV of £1 @ 10% in 1 years time is 0.9090

- If you invested 0.9090p today and the interest rate was 10% you would have £1 in a year's time
- Process referred to as: '**Discounting Cash Flow**'

According to Baker and Powell, (2005) NPV is the only method that provides an objective criterion for making decisions that maximize shareholders wealth. NPV approach provides theoretically correct "accept-reject" decisions for both independent and mutually exclusive projects based on their effect on shareholders wealth.

Drawbacks of NPV

From the research work, NPV method mostly depends on the discount rates and these rates and may vary according to the market fluctuation. Therefore due to its sensitivity this method is not as useful for comparing to other methods.

3.4.4 Internal Rate of Return (IRR)

Internal rate of return (IRR) is an investment measure that closely works with NPV. McAllister and Editors, (2009) explains when the future cash flows of an investment are discounted using the IRR, their present value will be exactly equal to the initial investment amount.

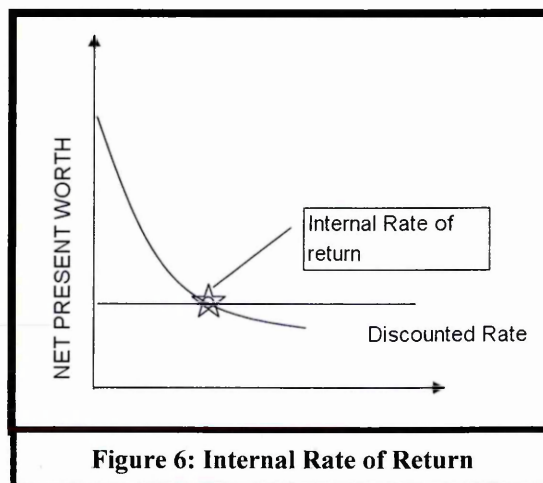

Figure 6: Internal Rate of Return

IRR analysis begins with cash flow stream and use some predetermined social discount rates to discount future benefits and costs.

$$\sum_t \frac{B_t}{(1+i)^t} = K_0$$

Where i is the rate of discount which solves the equation

In order to decide whether or not to include IRR in a business case summary, the following points should be considered

1. At any time the IRR should be higher, which in turn reduces risk
2. Investment value assessment (increasing or decreasing)
3. Timing of cash flow
4. Tiny investment or expenditure may lead to a magnificent IRR
5. Large cash outflow. (sometimes it can be misled, if there is no large cash outflow)

Drawbacks of IRR

According to Dasgupta and Pearce, (1972) the only drawback of the IRR approach is that the solution rate cannot be computed quickly. The reason is simply the IRR is the solution to a polynomial equation. Geddes, (2002) also agrees IRR cannot be calculated using a simple calculator and present value tables. It requires a scientific calculator or a computer spread sheet with the capacity to run iterative operation. In addition he states, IRR takes no account of the size of the project under analysis.

3.4.5 Payback Method

The payback method is the number of years required to recover the cost invested in a project or how long does it take to get the original investment back. Any project that falls short of the standard payback period (negative slope) should be rejected. A project can be accepted when adding the project's cash in-flow to its cost, until the cumulative cash flow turns positive. With reference to Idowu and Louche, (2011), the method stands that the shorter the payback period, the better the investment. He also states that the method is widely used where products get outdated quickly such as fashion and computer industries. In many situations this method is used for an initial screening

process because it is easy to use and to understand. One of the biggest advantages is that, it gives clear indication of project risk and liquidity issues.

Total Investment Cost

Payback in years = -----

Annual Benefit

Bolt, (2005) and Idowu and Louche, (2011) agree, one of the main important disadvantages of this method is that it ignores the time value of money. It also ignores profitability of the project but stresses the importance of liquidity. In common Frank Bolt, (2005) and Idowu and Louche, (2011) claims, whether this is an advantage or not will depend on the area of interest to the individual concerned.

3.4.5 Risk and Uncertainty

Knight, (1921) describes an eminent characteristic between "risk" and "uncertainty". In the view of Knight's, "*risk*" refers to situations where the decision-maker can assign mathematical probabilities to the randomness which he is faced with. In comparison, Knight's "*uncertainty*" refers to situations when this randomness "cannot" be expressed in terms of specific mathematical probabilities. In later stages there are many versions of definition for risk and uncertainty and is one of the most long running debates between researchers in financial management.

Risk is a common factor in any form of investments in business. In logic if you have more uncertainty, the risk is higher and vice versa. Twiss, (1926) describes "None of the evaluation techniques explicitly takes account of uncertainty with its associated risk". Uncertainty is particularly often high in engineering projects because of various deciding elements in the market.

3.5 Conclusion

After the detailed study about investment appraisal and its methods from various authors' perspectives, the conclusion is that investment in any major project in a business has to undergo a financial evaluation by taking expected cost and benefits, time, budget, risk and uncertainty. In an engineering business certain procedures and logical framework should be calculated because Twiss, (1926) says it has more residual ignorance. Therefore a meticulous financial evaluation has to be carried out before making investments in a bespoke engineering business to get a comprehensible outline of the investment.

CHAPTER 4 – COMPUTER AIDED ENGINEERING

4.1 Introduction

The need for rapid development in engineering businesses arises in the modern world. Updating and utilising the latest technology gives the solution to the business needs. This technology flavours in the name of computer and its related accessories. Design and drawing is the heart of any engineering business. To make the heart run fast and efficient with full brain power computer aided drawing and technology came in to engineering businesses. This helps to a great extent in better utilising time and maximising the efficiency of the product. Evolution of computer into engineering business made so many people's life easier and effortless.

4.2 Computer Aided Engineering (CAE)

CAE is a group of techniques used to develop or engineer a product with the aid of a computer. In the last century and in the present century, the world has undergone drastic and exceptional changes in human lifestyle. The reason behind the growth is an amazing impact of science and technology. People's lives are enriched with the increased amount of growth in the quality of living. The information era was born in the last decade, where connectivity and computer software products are driving the people and their economy. The information and knowledge gathered in this period is huge and is widely spread from agricultural, engineering to space science. The development of CAE technology has become more popular in this period and is growing day to day with the outside world.

As the marketplace is changing so rapidly, it has become indispensable for companies to merge with the new technologies as quickly as possible. To keep themselves ahead of their competitors, the companies are thirsting to implement the advanced techniques into

their business. Techniques such as modelling by CAE systems are extensively used around the world in different kinds of industries although this report is particularly focused on its uses in a Bespoke Engineering Businesses. According to Meguid, (1987) “CAE is a combination of techniques in which man and machine are blended into a problem solving team, intimately coupling the best characteristics of each.” Since the emergence of CAE in 1960s, the workload of the engineers has been reduced and an increase in productivity can be observed. A calculation that took a day for an engineer in those days can currently be solved within hours with the help of state of art techniques in CAE. However according to Schaefer, (2006) after second generation CAE invention, due to increased complexity in an engineering design project then lead time and productivity remains unchanged. He also states that new generation CAE systems are constantly developing with various key requirements like intelligent, interactive, automatic interfaces. Since its capabilities increased day to day, many companies are busily implementing it into their business. A Census by Jusko, (2007) in IndustrialWeek journal says 64.3% of companies who employ more than 500 people, implemented CAE compare to 43.1% of companies who employ less than 100 people. This also indicates overall 52.4% of companies have finished implementing these advanced techniques and shows the growth of CAE techniques in this modern world and how crucial it is to growing companies

4.3 CAE Advantages

CAE is about applying computer technology to all stages of product development. The main advantage of the use of CAE is the ability to test, simulate and possibly validate a product in a 3D context without having to physically build the machine, which in turn saves material, money and time.

The following points add more value to CAE and its implementation:

1. More realistic way of engineering products with minimum risk involved.
2. Highly sophisticated in performing multiple tasks and saves more time.
3. Optimum material usage leads to reduction in cost
4. Eliminates prototype in design to manufacturing phase. Hub Pages.,(2010).
5. Easy linking of Design and Manufacturing systems, this leads to minimum error in design and accurate finish of product.
6. Faultless data management system provides great support in re-engineering.
7. Animation or Simulation techniques help the end user to understand the product.

4.4 CAE Application

CAE and its application are most important in today's field of engineering. In detailed engineering business, the computer integrated product development cycle starts from the concept sketch to the final manufacturing definitions. Figure 7, gives details about the various techniques used to develop a product in a bespoke engineering business.

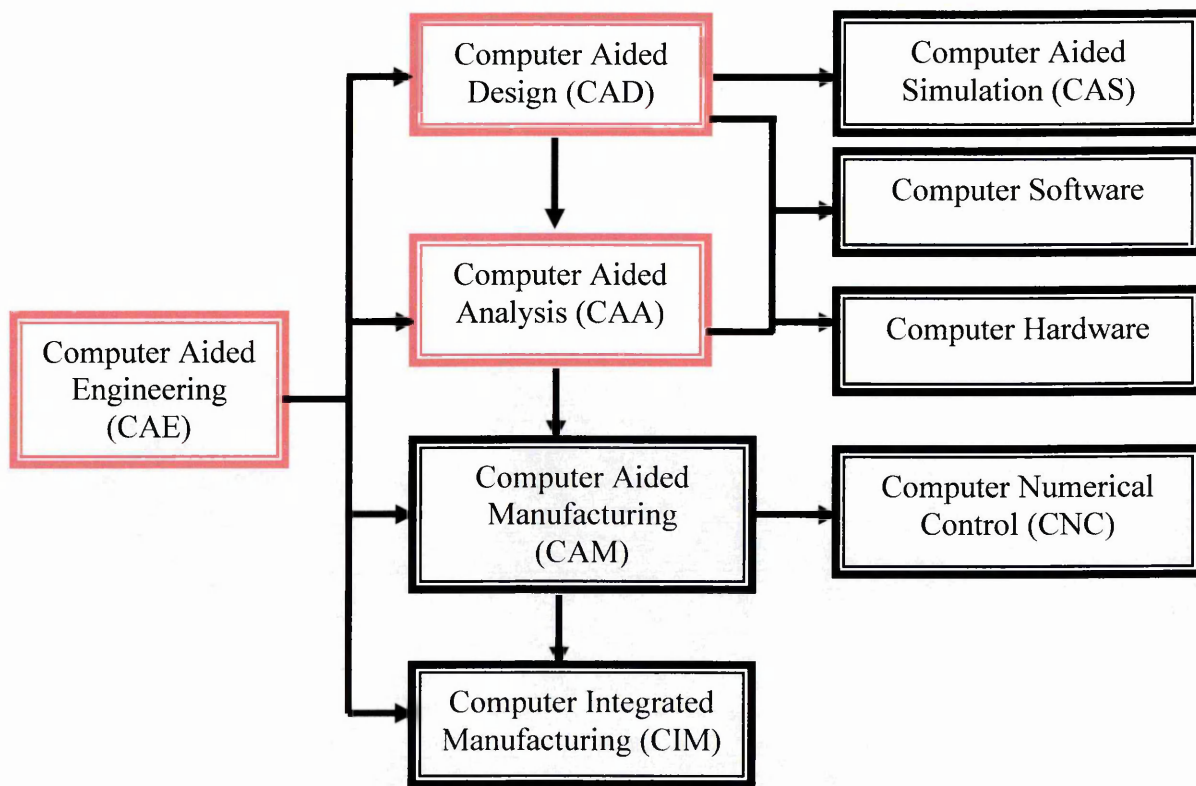

Figure 7: Computer Aided Engineering – Application

4.4.1 Computer Aided Design

Evolution of Computer Aided Design (CAD) was a phenomenal milestone achieved in the engineering sectors to perform geometric modelling. CAD originated when it became possible to turn paper drawings into computer files. After first step in CAD's invention in 1960's, it made life easier in terms of drawing and became more practical in usage for the designers and application engineers. Since its start, it is one of the evergreen techniques which are on the rise to make even more sophisticated and economical method used by engineering industries. Bone, (1994) and Alavala, (2008) explains, CAD uses computer to display graphic images on a mathematical co-ordinate system.

Hsu and Sinha, (1991) explains all the major functional elements of computer-aided-design (CAD) and its development as shown in Figure 8. He also states that CAD can enhance the quality of engineering design with excellence representation product geometrics. It also enables clear visualization of the product in different drawing angles and by integrating to other CAE system can eliminates big mistakes like dimensional error (tolerances and interferences), data storage and building prototypes. At the same time the success of CAD is purely depends on the software programs and hardware used to develop a design. A good software program with a decent hardware configuration could lead to significant improvement in design productivity, which in turn reflects in manufacturing improvements (fast-stream production cycle). Medland and Burnett, (1986) also describe how the speed and number crunching capacity of the computer could make feasible large amounts of design calculations. On the other hand, it also depends on the designer's capability and adaptability to that particular software. Therefore in order to achieve significant improvement in design and manufacturing the above mentioned points are to be carefully examined and implemented.

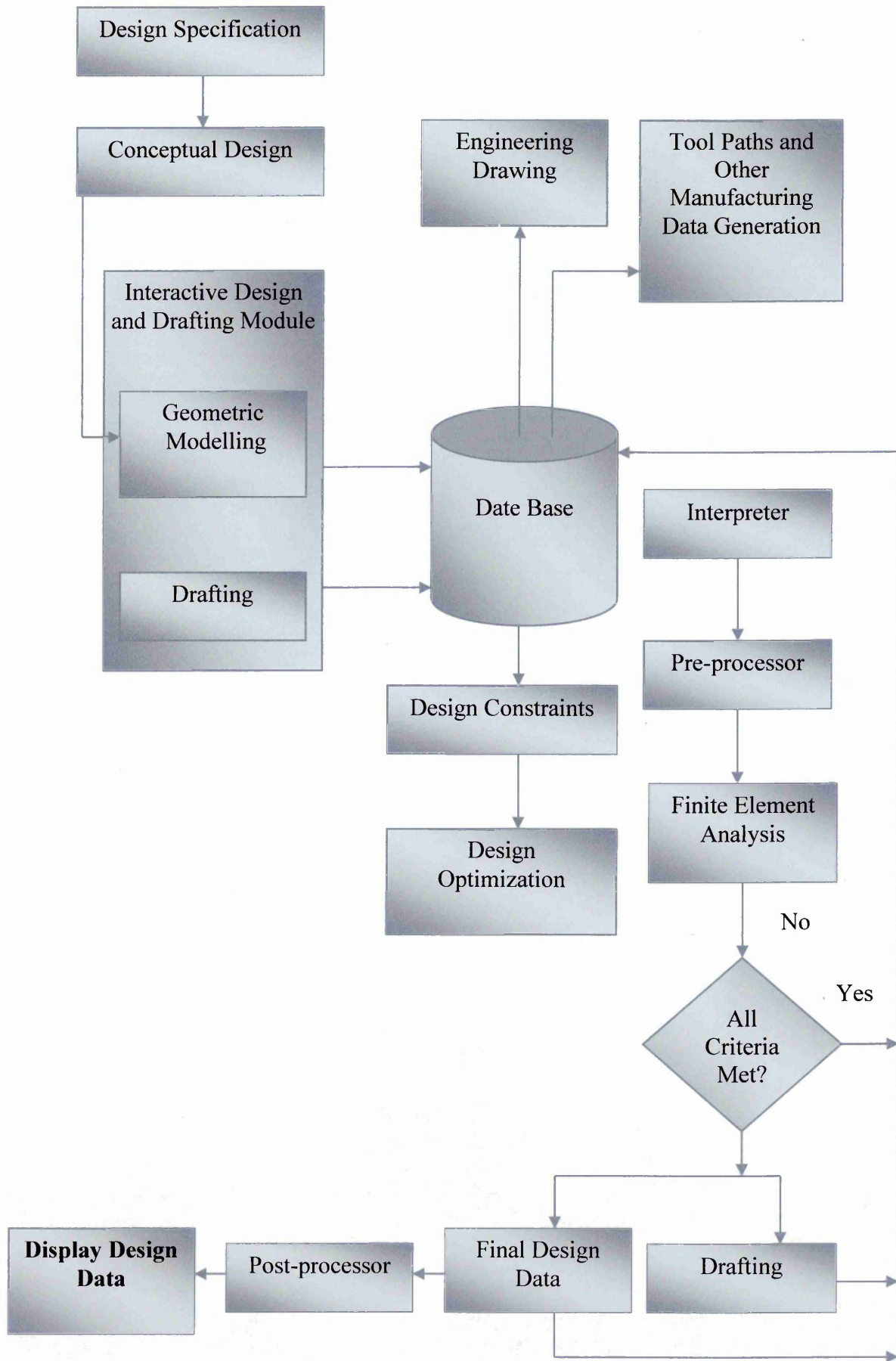

Figure 8: Major Functional Elements of CAD System: (Hsu and Sinha, 1991)

4.4.1.1 CAD Developments

Developments in CAD drive big manufacturing firms and OEM's in terms of usage (time) and potential savings in design, manufacturing, sales and after sales market. This make drastic changes signal the small scale industries and individual users to make investment. Cadazz., (2010) a website source indicates, the initial stages of CAD started with a program called SKETCHPAD in early 1960's. The same was discussed by Reid, (2007) as part of his PhD thesis, who explains as the technology grew, this was developed by several other companies according to their own use until mid-1970. The next stage starts with 3D complex curve options and continues towards 3D Solid Modelling. He also notified a Survey shows that after the invention of 3D CAD market the whole sector raises from \$25 Million to \$1 Billion in just four years. This shows the effect of cost benefits achieved and investor's interest towards the product.

4.4.1.2 3D CAD System

3D modelling is one of the fast growing technologies, which represent a physical component as a solid object. Simmons, et al., (2009) clearly points out that 3D or solid modelling is now used as the tool of choice for engineering design throughout the industry. He also states the whole process is driven by the race to shorten 'time to market' by the full exploitation of the benefits of using the 3D model as a master. Green, (2007) suggests industries should use 3D resources in the places where they can get the best possible payback.

The process starts with developing a mathematical, wireframe representation of any three-dimensional object via specialized software. The product is called a 3D model. It can be displayed as a two-dimensional image or improve visualisation through a process called 3D rendering and even can produce manufacturing drawing with automated dimension facilities

4.4.1.3 2D to 3D CAD

Converting 2- Dimensional to 3- Dimensional CAD has been and still is a huge growing market, where industries are gearing their facilities to top extent in order to acquire a place in the market and to decrease their design to manufacture time. But, Lamit, (2007) describes the key to success comes down to evaluation how effectively a 3D modeling system addresses the fundamental transition concerns:

- Productivity (usability and learn-ability)
- Legacy (2D designs data)
- Cost (total cost of ownership and cost of use)

The conversion is quite a long process which involves installing the new system (Hardware and Software), training, support and managing. The time consuming in these process are very crucial for production and its associated activities. Therefore the migration needs to be step by step process and needs to be very cautious in the move and selection. If there is any disturbance in the process, then it will be so difficult to manage the system.

4.4.2 Computer Aided Analysis

This is the phase immediately after the design cycle in a typical manufacturing environment. Analysis is a essential tool for the design process to achieve its maximum strength and reliability. A perfect design and its associated problem originate in various different environments and are subjected to various scenarios such as loading conditions and external forces. These variables are taken into account and analyse accordingly using computer simulation software programs as a mathematical model. Dukkipati, et al., (2007) explains the designer can make a choice of analytical method to solve the mathematical model from various methods available in market such as finite element method, finite difference method and transfer matrix method.

The typical analysis starts with a methodical environment (boundary conditions) study and selection of proper material. This gives accurate and reliable results with allowable safety factor towards the life of the structure. The final result gives indications for the design optimization and design risk assessment.

Design optimization is the major decisive factor in the engineering environment. Using CAA, the design can be optimized by shape, details and material. This gives vital edge to the cost factor 20-30% savings of the project cost. Dukkupati, et al., (2007) also points out the main objective may be to minimize the overall cost of the final product or minimize the overall weight of the product as in aerospace industries or maximize the strength and aesthetic appeal of the product. Design risk assessment is a process, which indicates the failure of the design under various circumstances. The main intention is to make the design safe and reliable to use with minimum cost and time.

4.4.2.1 Finite Element Analysis

Finite Element Analysis is a computer based simulation technique used to analyse the structure and describe the behaviour of the structure under various possible scenarios (load cases and boundary conditions).

Metal forming machines are best known for rigidity in the structure, because low rigidity will reduce the accuracy and definition of the formed component. Recent technologies in FEA have provided the capability to check the rigidity of the structure by taking all possible load cases, boundary conditions and material data. The results are then compared to the yield and tensile strength of the material with a allowable factor of safety to maintain the reliability of the product. On the other hand Bathe, (1996) says in his article under question of reliability “reliability means that in the solution of a well-posed mathematical model. Also Bathe, (1996) indicates, the finite element approaches two attributes: The finite-element solutions will converge to exact solution of the mathematical model as element size approaches 0 for any material data, displacement

boundary conditions and load applied: and for a reasonable finite element mesh, a reasonable finite element solution will be obtained. Furthermore, Bathe, (1996) describes the quality of finite element solution does not change drastically when the material data are changed”.

FEA also enables the performance of fatigue analysis in which the components are subjected to an alternating stress by repeated cycles of loading. This is quite important that Hancq, (Ansys) estimated that 50-90% of structural failures are due to fatigue. Therefore, by introducing quality fatigue design tool technique in developing Rubber Die Press and the associated product family will deliver significant improvement for the business.

4.4.3 Computer Aided Animation

Computer Aided Animation is the visual creation of objects in two dimensional or three dimensional. Wells, (1998) describes animation and the word developed from a Latin verb “animate” means “to give life to”. Basically animation gives life to the stationary object to form an illusion of movement. Animation software was originally developed in the 1980’s and were purely in the format of flash creations (mathematical code generated format) and as the technology developed the field animation tuned in to a huge market with the background of computers.

Computer generated animations becomes more prevalent in all industries starting from film making to manufacturing. The growth was enormous within the decade from 1990-2000, with the use of multifunctional computers ranges from small, medium sized to mainframe computers. The graphic displays developed from these computers are used to generate the video format of the animation.

In the field of the engineering/manufacturing, the virtual concepts of new products were developed into working model using animation to enhance marketing and sales. The

working model will then convert into live environment to facilitate the understanding of the behavior and constraint with respect the limitation.

4.5 Selection of CAE Software

Raphael and Smith, (2003) explain the answer to the question ‘what makes computer-aided-engineering software a good return on investment? In house engineering software is often written by engineers who have no formal training in computer science. Furthermore, development of the software often finishes before they adequately understand the business and tasks. Under such circumstances, for only a short period of time the software works and only in the presence of the developers. When the developers leave the software, the technology becomes obsolete and difficult to revise. This leaves the engineering firms and industries with a tremendous cost and not many of industries can afford to get distracted and loose all their time and money

In such cases, the use of commercial software package finds the best place inside the business. The development in commercial software picks up its peak in early 1996’s and this gives more security to the business and their development needs. Still industries are using their own developers but they have major contracts with the commercial software people for their backups.

Selection of commercial software plays a vital role in the business and contributing to the generation of its revenue. The major concepts between the software packages are quite similar but at the same of time there are lots of criteria which need to be analysed before making decision. The factors are mainly cost dependent and application based. After making a proper comparison in all basic aspects and thorough understanding about the package, the decision can be made because poor application can lead to drastic changes in business outcomes.

4.5.1 Selection Methods

CAE software selection is a growing problem in a bespoke engineering business. The companies have to make a detailed study about the business needs and about the impact of the changes in the business. By following the listed criteria below, the company is able to make a good selection:

A. Business aspects - The Company needs to have a clear and focussed idea of the software selection in order to avoid unnecessary consumption of time and financial strains. The following are some important guidelines considered in selecting the software for Joseph Rhodes Limited:

1. What is the current level of design usage?

The level of usage is purely dependant on day to day activities of the company. In order to determine the usage of a small industries or medium sized business, one must know the full detail of the company's nature and its products. In the event of finding level of usage for Joseph Rhodes, the products and day to day activities are extremely difficult because of the nature of the business as described in chapter 1.

2. What level of usage might be required in the future?

Requirements are completely based on the company growth chart, market trend and interviewing the user. In regards to Joseph Rhodes, Proper assessment of pre and post contract activities for at least 3 years and analysis of level of usage helped to identify the exact requirement.

3. What level of facilities is required in the current and future in terms of software and other hardware accessories?

Based on the requirements and benefits achieved from previous activities such as using trial software and reading user interface manual, will help to identify the levels in the software. Hardware needs to be updated constantly to suit the software versions.

4. How many licenses are required and will it increase in the future?

Number of licenses and its future requirement are only predictable through the company growth and market trend.

5. Will the product having capability of product data management?

Product data management is a tool capable of storing and retracting all the information generated during the design process. This reduces all the paper work carried out for production and quality process.

All the above listed guidelines will help the company to determine if there is a indispensable need to be bring up to date the software and to understand the present standing of the business in the market with cost effectiveness.

B. Market Analysis – To compare and contrast the various software available in the market to the company and thus determine the software that will satisfy all the business needs for the continuous development.

- a) What are the available software's in the market?
- b) How many users are operating in the market?
- c) What is the current and future position of the software developer?
- d) What software is used by the customer and supplier to ease the transfer of information?
- e) Are regular revisions (updates) given by the developer?
- f) Does the developer provide any add-ons like i.e. 3D software with FEA package?

C. Cost Comparison – Compare the following:

- a. The cost between software's, in terms of band new purchase and upgrades.
- b. The maintenance fees.
- c. The cost for training employees.
- d. The cost of upgrading hardware and other accessories.

Answering these questions led to a choice between two major PC systems; Autodesk., (2007), which are compared to Solidworks., (2007.) in the below Table 3. Eventually Inventor was selected due to compatibility with AutoCAD 2D drawing system available in-house and by many potential customers.

Table 3: Cost comparison between Inventor and Solid works done in 2007 at Joseph Rhodes. (Ramakrishnan, 2007)

SOLID WORKS (NEW LICENSE)				INVENTOR (NEW LICENSE)			
DESCRIPTION	QTY	UNIT PRICE	TOTALS £	DESCRIPTION	QTY	UNIT PRICE	TOTALS £
SOFTWARE	4	5500.00	22000.00	SOFTWARE	3	4700.00	14100.00
Subscription	4	1250.00	5000.00	Subscription	3	1250.00	3750.00
Training	4	1250.00	5000.00	Training	3	1250.00	3750.00
Hardware	3	1500.00	4500.00	Hardware	3	1500.00	4500.00
TOTAL			36500.00	TOTAL			26100.00

INVENTOR SUITE WHEN UPGRADE				INVENTOR SUITE + ANSYS (ANALYSIS)			
DESCRIPTION	QTY	UNIT PRICE	TOTALS £	DESCRIPTION	QTY	UNIT PRICE	TOTALS £
SOFTWARE	3	1650.00	4950.00	3D SOFTWARE	3	1650.00	4950.00
Subscription	3	1250.00	3750.00	Analysis Software	1	6500.00	6500.00
Training	3	1000.00	3000.00	Training	3	1000.00	3000.00
Hardware	3	1500.00	4500.00	Hardware	3	1500.00	4500.00
Subscription	3	1250.00	3750.00	Subscription	3	1250.00	3750.00
TOTAL			16200.00	TOTAL			22700.00

4.6 Conclusion

Computer Aided Engineering has its own merits and de-merits while using, developing and implementing into the business structure. As discussed in the above sections, the important criteria in implementing CAE techniques into the business is to have a proper plan, research work, market analysis and good selection methods will benefit the business to a greater extent. In the event of software selection for Joseph Rhodes, it was examined as per the selection methods mentioned earlier and concluded with the selection of Autodesk Inventor. This resulted in £20,300 savings in software selection as shown in the Table 3. Also by predicting and calculating return on benefits will reduce

the risk in technology transformation. Technology transformation plays a vital part in the growth of business; the transformation needs to be in stages/phases in a prolonged period not an over-night process. The stages and the period is completely depends the nature of business and their needs. For an example, a typical bespoke engineering firm like Joseph Rhodes will take a minimum of two years to complete the process and to taste the benefits.

CHAPTER 5 – DESIGN OF RUBBER DIE PRESS

5.1 Introduction

The work discussed in this chapter explains how advanced CAE applications contributed to one particular large scale project, Joseph Rhodes Rubber die press, which typically costs from one to two million pounds. This chapter also focuses on the benefits achieved by implementing CAE applications for designing a “state-of-the-art press”.

Throughout this chapter, typical CAE applications were utilized to determine the usage of advanced techniques in sales (winning orders) and training, material savings and improving the strength of the fabrication, is discussed and a typical example of CAE influence and technology change in manufacturing the rubber die press from 1965 to 2008 is shown in the below Figure 9.

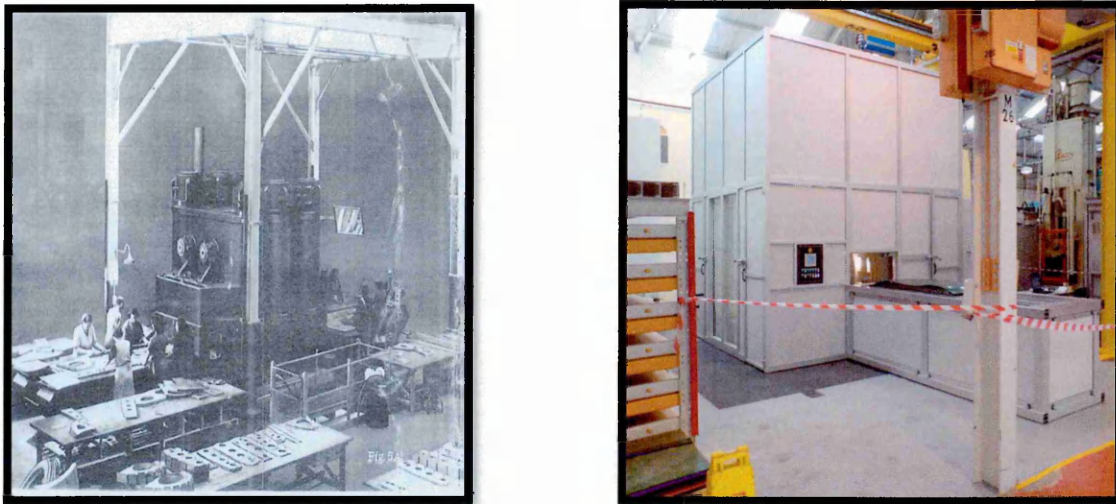

Figure 9: Rubber Die Press (1965 and 2008) - John Shaw and Joseph Rhodes Limited

5.2 Background of Rubber Die Press

Metal forming technology has existed for many centuries, however it has been industrialised in the 1980s. It became more prevalent during and after World War II, due to an increasing need for making aerospace components. Since then this technology has been serving all varieties of industries ranging from household to aerospace. Normally,

when producing large quantities of formed components (mass production) from sheet metal, conventional single acting, double acting or single acting press with pneumatic die cushions and hydraulic presses are used. In the same circumstances, the provision of high quality precision press tools involves considerable expenses for running and maintaining. However, the expense can usually be reduced to an acceptable 'cost per part' when bulk quantities of parts are required. On the other side, when production requirements are limited, the tooling cost cannot be justified and therefore alternative method of manufacture was needed. When these conditions prevail that the advantage of using a rubber die press became apparent.

Normally with the power press, the components are formed between a top and bottom die. In rubber pad forming press, the top die is replaced with a natural rubber.

Lascoe, (1998) states that the rubber dies is are on the ram of the press and the form block is on the platen. The metal component is contoured to the bottom die and forming a highly polished or plated sheet, ensuring that the metal is formed without being scratched.

Lascoe, (1998) also noted that there are many advantages to rubber die presses, where one rubber pad can be used to make many different components because it returns to its original shape, when the pressure is released. Also when compared to conventional tools, rubber die presses have fewer components and are made of easier-to-machine materials. Conventional dies have a fixed radius, while rubber die presses radius decreases progressively with each forming stroke. The worked metal does not thin in rubber die presses as it does in conventional deep drawing presses. A major disadvantage of rubber die presses are the rubber wears out quickly; the average life of rubber pad is about 20,000 pieces. Compared to the conventional dies, the definition of the component maybe less sharp because the rubber pad exerts less pressure, therefore special or ancillary equipments may be needed.

There are three types of processes in production of rubber-pad forming presses. The Guerin process is the oldest and most basic, where the press ram and the rubber pad are about the same size, however depends on machine specification and other influences either one can be smaller size. The main tools are the rubber pad, which is a soft, solid block of rubber, and form block can be made of wood, plastic, steel, or alloys of aluminium and more. From the Guerin process Figure 10, the Verson-Wheelon was developed. Mainly it is used for higher pressure and is primarily used for forming shallow parts, where the rubber die is used as either die or the punch. The Verson-Wheelon press (Figure 11) has a horizontal cylindrical steel housing, which contains a hydraulic fluid cell that can inflate or expand as fluid is pumped into the cell. This exerts a downward force on the rubber pad, causing it to flow over and around the form block, creating the component.

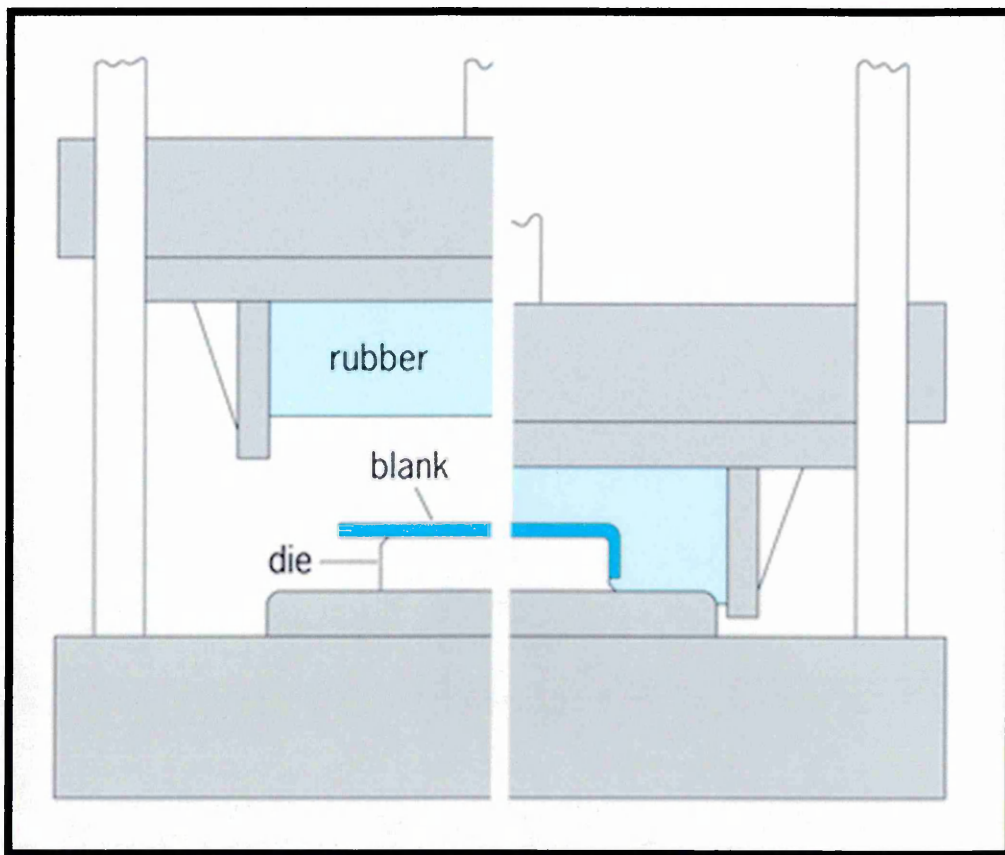

Figure 10: Guerin Process (Technology, 2005)

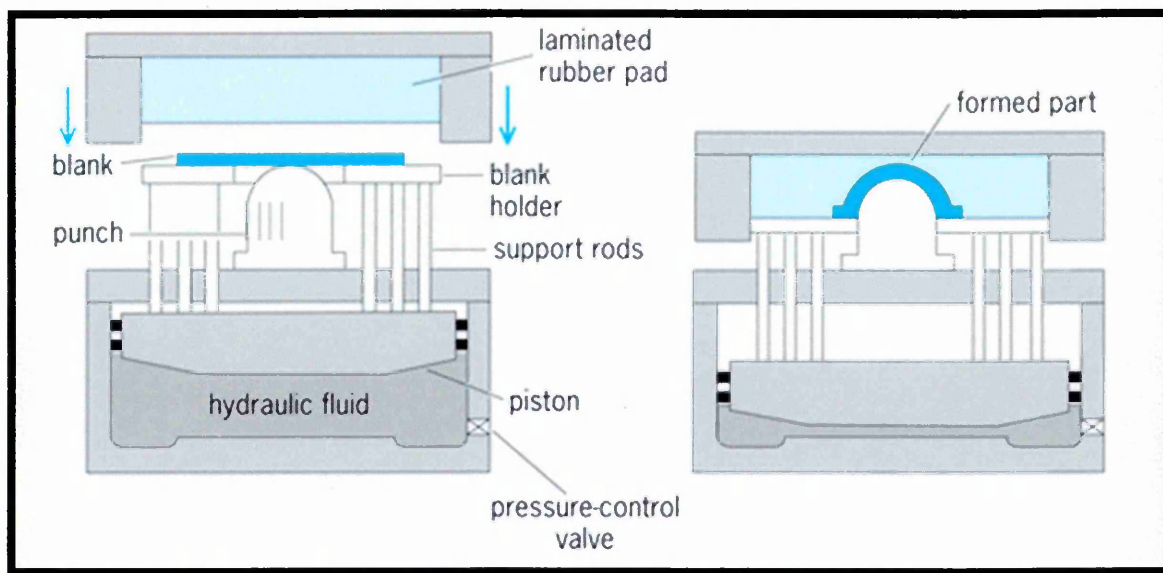

Figure 11: Verson - Wheelon Process (Technology, 2005)

The last process is Marform (Figure 12) which is an inexpensive alternative to the Guerin and Verson-Wheelon processes. It is best suited to a single-action hydraulic press, where the speed and pressure can be varied and controlled.

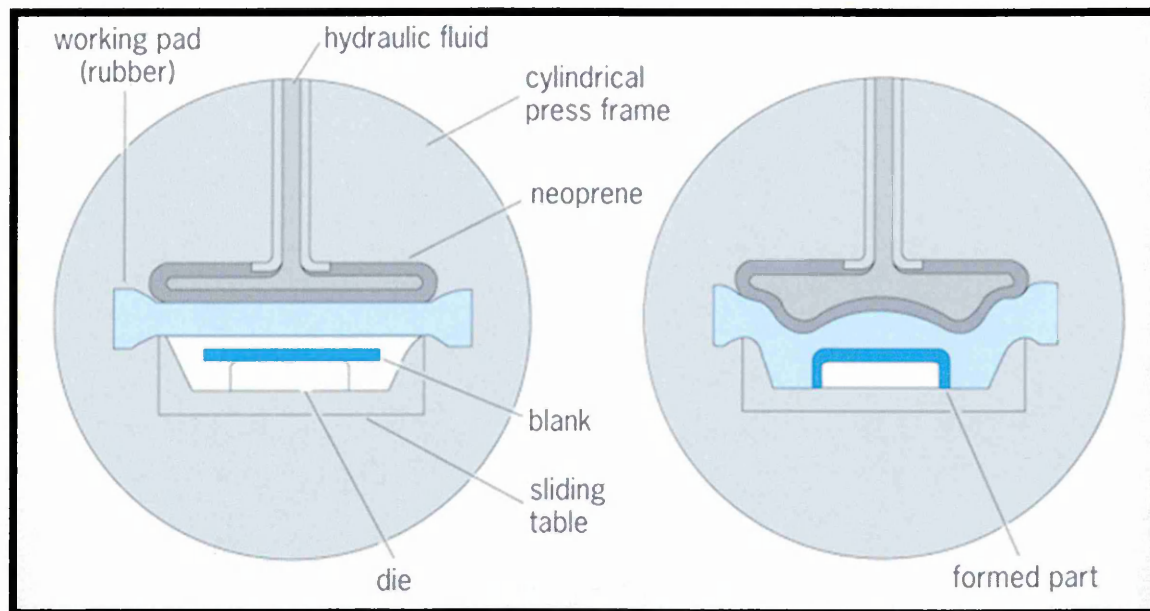

Figure 12: Marform Process (Technology, 2005)

In the pad forming press an attempt has been made to eliminate and replace the top die with a natural rubber of shore hardness of 65-80. The shore hardness of the rubber is selected by the force required for forming the component. The liquid rubber extracted

from the source is poured into a mould for solidification in different levels to form the required shape with accurate hardness.

5.3 Principle of Operation

Stage 1: Loading

The process of loading is when the blank to be formed is placed on top of the moving table for pressing. As shown in Figure 13, the bottom tool is built in as a male former that imprints the shape of the component to be formed. The rubber pad needs to be in good fit with the pad for safe operation. The Hydraulic cylinder is fitted to the moving table will give the vertical movement which then cause the blank to penetrate into rubber to form the required shape.

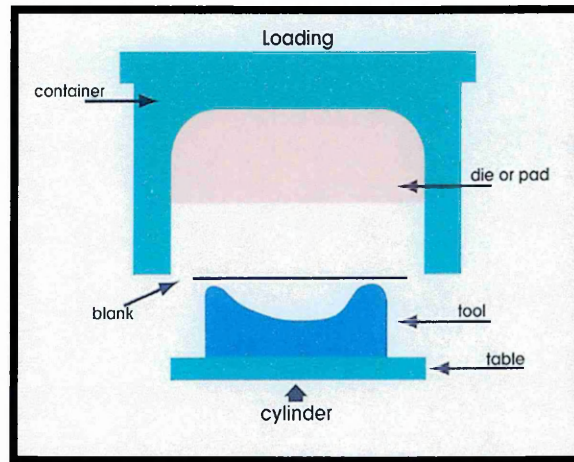

Figure 13: Principle of Operation - Loading

The required pressure is applied stage by stage by using the hydraulic cylinder according to the size and shape of the component (Figure 14). Depending on the tonnage the maximum surface pressure will be generated in the rubber to form the component. Sometimes, this causes damage to the rubber and rubber pad surface resulting in huge distortion and disintegrates into granules. To prevent the distortion on the surface of the pad, rubber slave sheets are employed which gives better shape for longer use and better rubber life. The slave sheets are separate slabs of rubber

Stage 2: Forming

The required pressure is applied stage by stage by using the hydraulic cylinder according to the size and shape of the component (Figure 14). Depending on the tonnage the maximum surface pressure will be generated in the rubber to form the component. Sometimes, this causes damage to the rubber and rubber pad surface resulting in huge distortion and disintegrates into granules. To prevent the distortion on the surface of the pad, rubber slave sheets are employed which gives better shape for longer use and better rubber life. The slave sheets are separate slabs of rubber

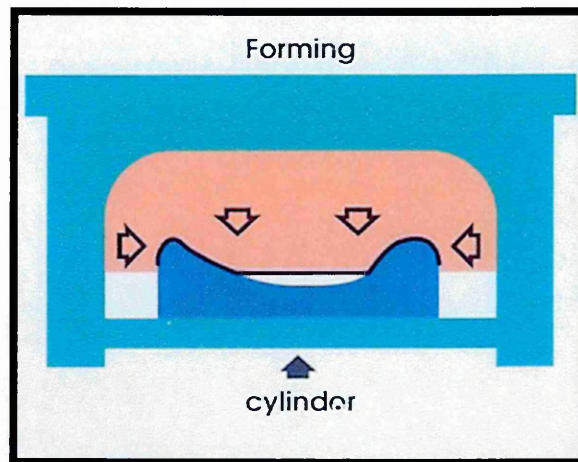

Figure 14: Principle of Operation - Forming

causes damage to the rubber and rubber pad surface resulting in huge distortion and disintegrates into granules. To prevent the distortion on the surface of the pad, rubber slave sheets are employed which gives better shape for longer use and better rubber life. The slave sheets are separate slabs of rubber

about two inch thick are interposed between the rubber block and the die during operation.

Stage 3: Blank Holder Effect

Blank Holder effect is the force exerted by the pad holder on the blank which supplies the restricting force that controls the metal flow (Figure 15). To minimise the blank holder effect, the pad holder needs to be carefully designed by having bigger radius on all the edges and enforcing the rubber pad depth to be at least 0.25 inches deeper than the flange which is to be formed on the component

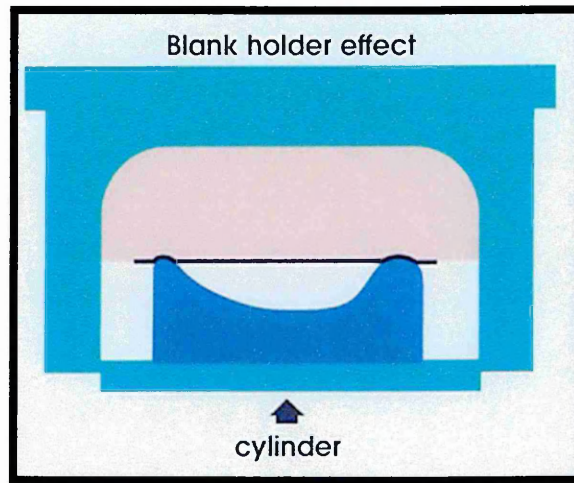

Figure 15: Principle of Operation - Blank holder Effect

component

Stage 4: High Pressure Calibration

This is the final stage of the forming process. Depending on the complexity of the components (Figure 16), the pressure is removed after the sustain condition, the bottom die releases slowly with the formed component. The rubber will then go back to its original form without any distortions.

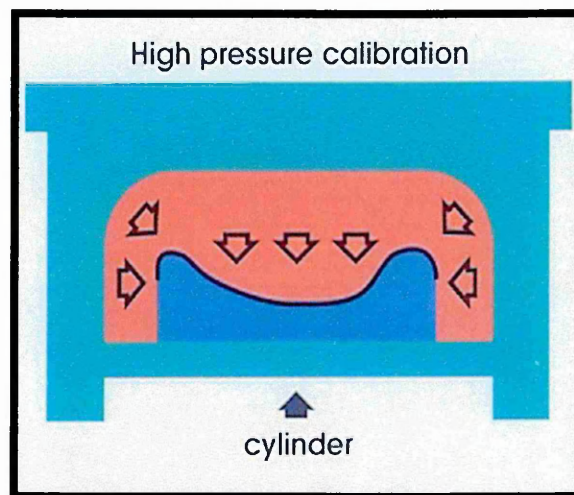

Figure 16: Principle of Operation - High Pressure Calibration

5.4 Types of Rubber Die Press

There are two distinct types of presses which are classified by using different tools for producing different products. Hard rubber with a surface pressure up to 1.5 tons per sq.

inch on the metal is described as the high-pressure presses. Soft rubber with very low surface pressure up to 0.5 tons per sq. inch is described as the low-pressure presses.

5.5 10,600 Tonne Rubber Die Press

Joseph Rhodes manufactured a high pressure rubber die press for the aerospace industry at a cost of £1.5 million in 2007. It is classified to be the world's largest rubber die press which has 10,600 ton capacity with a surface pressure of up to 454 Bar as shown in Figure 17 Figure 18 and 18. The press is constructed with an innovative multiple plate frame construction with a large stationary pad holder, while the moving platen can be moved up in contact with the rubber with one main hydraulic cylinder and two side cylinders. The completed press contains two-draw plates which offers double side production process in around 75 seconds cycle time with a fast and slow approach. The whole arrangement is made simple to have all working parts underneath the press without obstructing the working space. The press operates with a state-of-art hydraulic system and Siemens PLC controllers.



Figure 17: Testing of 10600 Ton Rubber Die Press



Figure 18: On site - 10600 Ton Rubber Die Press

5.6 Development of Rubber Die Press

5.6.1 Business needs

In recent days, there is an increase in demand for high tonnage forming presses in aerospace industries, which is well known for high quality and health and safety marks; However the higher the tonnage, the higher the risk in maintaining the standards. Therefore the basic press structure and its component have to undergo rigorous analyses and testing under various possible scenarios in order to prove its capability in terms of strength and rigidity. To achieve high standards in design and manufacture, the need for advanced CAE techniques like finite element calculations and 3D modelling arise. On the other hand, the company has to balance the cost between spending in implementing these techniques and the outcome achieved.

5.6.2 Implementation of CAE

This particular section details the CAE implementation, different phases, activities and the time required to execute those activities throughout the project. The work commenced with the customer specification and the requirements to satisfy their production schedules. The plan was prepared and achieved in 2008 at Joseph Rhodes Limited. The total time required from concept phase to analysis phase and preparing final manufacturing drawing was less than 25 working days as shown on Table 5, whereas before CAE implementation the process would have taken 50 to 60 working days. As of 2008, a mechanical design engineer is paid between £20 to £25 /hour and mild steel material approximately £900/tonne. A cost analysis was also made and is presented in Table 4, which explains a typical time based calculation before and after CAE implementation in Joseph Rhodes Limited. Also included is an estimate of material weight and cost savings due to FEA as a consequence of detailed analysis. These benefits are further detailed in subsequent sections.

Design Time

Table 4: Cost Saving in terms of Time and Material - Before and After CAE Implementation

Before CAE Implementation	Time required to finish= 60 day *7.5hr/ day = 450 hr	Total Cost = 450 *25 = £11,250.00
After CAE Implementation	Time required to finish= 20 day *7.5hr/ day = 150 hr	Total Cost = 150 *25 = £3,750.00
Difference	Hours Saved = 262.5	Cost Saving = £7,500.00

Material

Before CAE Implementation	Eg: Analysis of Press structure and Main Hydraulic Cylinder = 140 Tonne	Total Cost = 900 *140= £126,000.00
After CAE Implementation	Eg: Analysis of Press structure and Main Hydraulic Cylinder = 95 Tonne	Total Cost = 900 *95 = £85,500.00
Difference	Material Saved = 45 Tonne	Cost saving = £40,500.00

Table 5: Time Plan - CAE activities (Rubber Die Press)

1	ID	Project Name	Days	Start	End	9-Jul	16-Jul	23-Jul	30-Jul
2	1.0	10,600 Ton Rubber Die Press	27	9-Jul	5-Aug				
3									
4	1.1	Concept Sketch & Animation Phase	10	9-Jul	19-Jul				
5	1.1.1	Define Customer Specification	1	9-Jul	10-Jul				
6	1.1.2	Define constraints	2	10-Jul	12-Jul				
7	1.1.4	Determine scope of work & principle of operation	3	12-Jul	15-Jul				
8	1.1.5	Develop Concept sketch	1	15-Jul	16-Jul				
9	1.1.3	Develop Animation	3	16-Jul	19-Jul				
10									
11	1.2	Design Phase	10	19-Jul	29-Jul				
12	1.2.1	Develop concept sketch to working design	4	19-Jul	23-Jul				
13	1.2.2	Define Material Selection	1	23-Jul	24-Jul				
14	1.2.3	3D CAD Modelling	4	24-Jul	28-Jul				
15	1.2.4	Finalise Design	1	28-Jul	29-Jul				
16									
17	1.3	Analysis Phase	7	29-Jul	5-Aug				
18	1.3.1	Import 3D Model to FEA software	0.5	29-Jul	29-Jul				
19	1.3.2	Setup boundry conditions and constraints	1	29-Jul	30-Jul				
20	1.3.3	Perform Analysis	2	30-Jul	1-Aug				
21	1.3.4	Identy stress points and deflection points	2	1-Aug	3-Aug				
22	1.3.5	Instruct design change	0.5	3-Aug	3-Aug				
23	1.3.6	Perform Analysis & Confirm	1	4-Aug	5-Aug				

Therefore the table 4 shows the details of the use of CAE and the benefits to a bespoke engineering firm providing a time saving and material saving process.

Benefits of implementation can be clearly seen at the product development process and the rate of growth of the business. In this case, CAE applications are discussed in chapter 2 such as 3D CAD modeling, finite element stress analysis and 3D animation are implemented towards the design and manufacturing aspects of rubber die press. Selection of these applications has been an important factor in order to achieve the maximum benefits such as publishing in the company website and incorporating the same in the company catalogue which is attached in Appendix 1. Business needs, market analysis and financial process such as rate of return, payback period were analyzed to find out the appropriate package available in market for the job.

5.7 Cost Matters

As a result of changes in the design, the final outcome is reflected in cost. Budgeting, spending and saving are the three main properties to be considered in detail to make a good profit. The following are some of the important benefits (in terms of cost) achieved by implementing CAE techniques as discussed in chapter 2 and in the development of the rubber die press.

5.7.1 3D Modelling

1. Saves time in creating one or more concept sketches for sales purposes
2. Helps the customer (non –technical people and/or financial people) to visualise the product (Figure 19)
3. Easy creation of detail drawing and sub-assembly drawing by saving designer's time and cost.
4. Shorter Lead Time- Design to Manufacturing (Time saving)

5. Sub-assembly drawings available for the machine operating/maintenance manual and training documents
6. Publishing in company catalogues and websites increases the customer and supplier attraction (Appendix 1).
7. Representing concept sketches in sales and marketing meetings helps in winning orders.

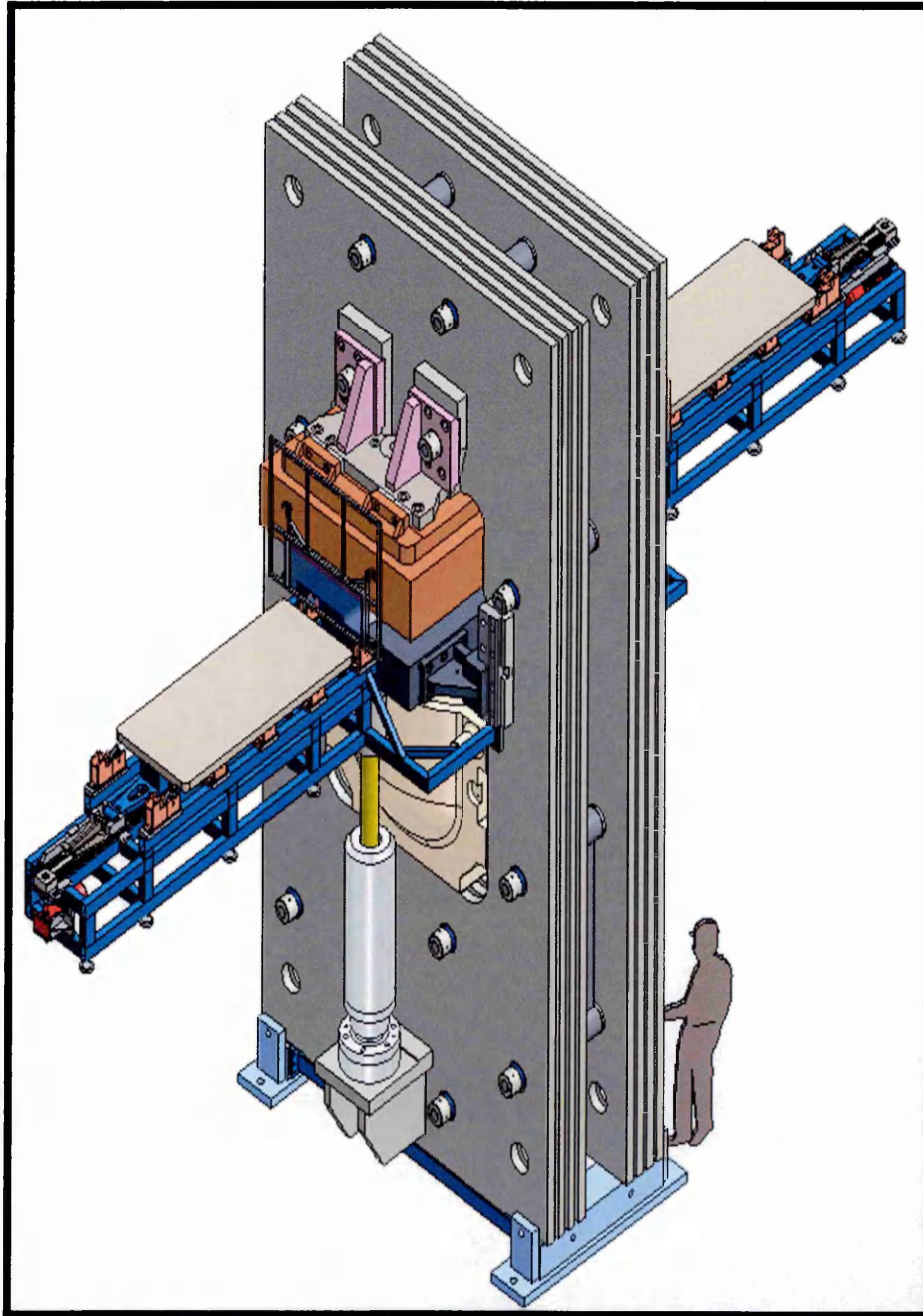

Figure 19: Rubber Die Press - 3D CAD

5.7.2 3D Animation

As described in Chapter 4, 3D Animation (Figure 20) is the tool used to define the virtual concepts of new products. A copy of animation are also provided in the Appendix 4

1. Useful for sales and marketing to a greater extent in winning orders.
2. Replaces 1000 words of explanation to customer's and supplier's question how exactly the machine works?
3. Useful in producing training and health and safety videos.
4. Displaying in exhibitions increases more attraction towards company product.

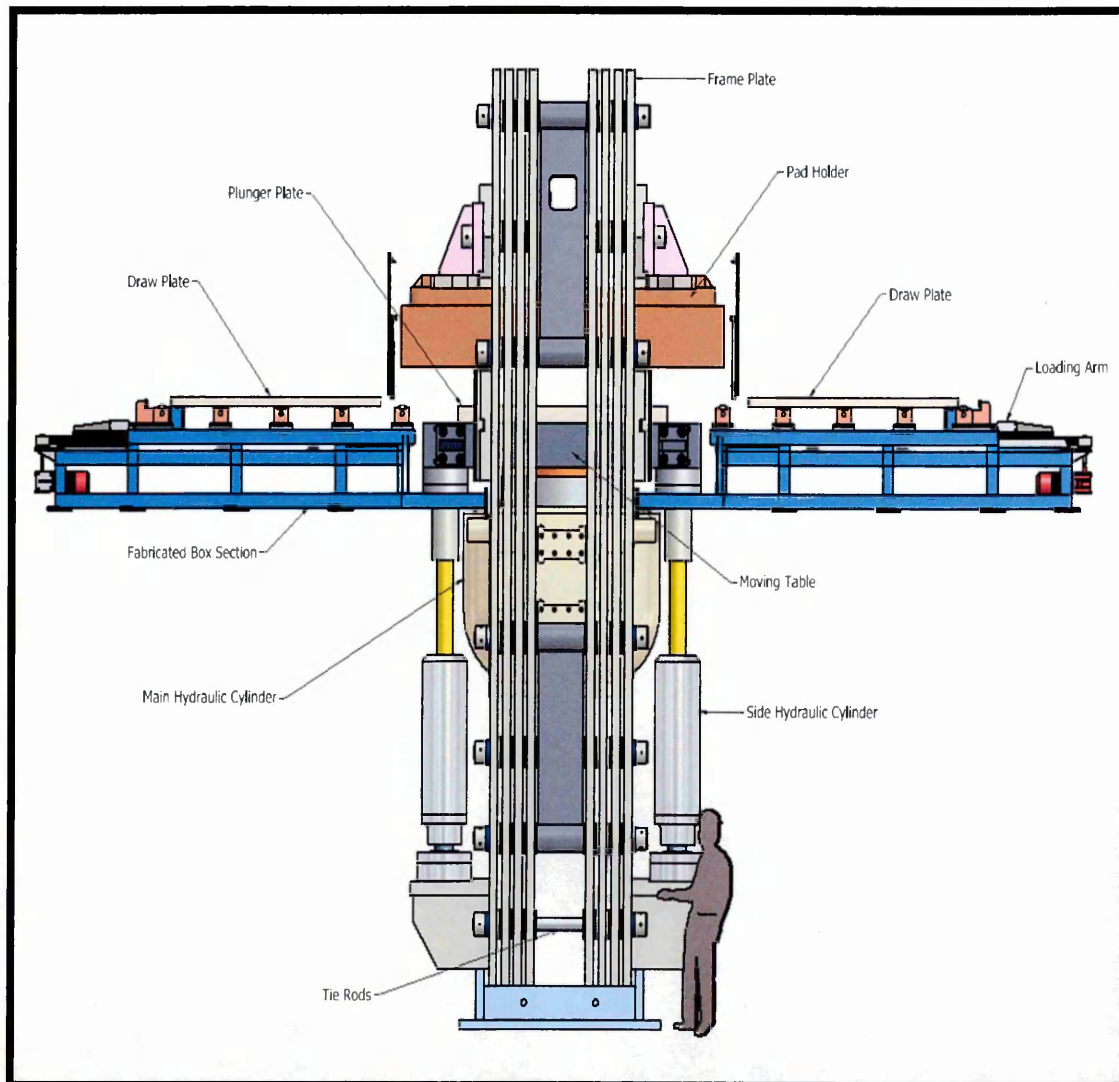

Figure 20: Rubber Die Press - Animation

5.7.2 Finite Element Analysis

1. As described in the benefits of FEA section, the software enables confidence and ability in designing for purpose, whilst reducing unnecessary material cost and resulted in savings as described in the benefits of FEA section.
2. Reduced handing and maintenance cost by reducing stress concentration and increasing safety factor. This gives more resalable and scrap-age value.
3. Replaced all the theoretical or traditional hand calculation to computer programming performance.
4. The ratio between inside and outside diameter was programmed in to the software (Figure 21) with reference to the design pressure and hoop stress for future reference.

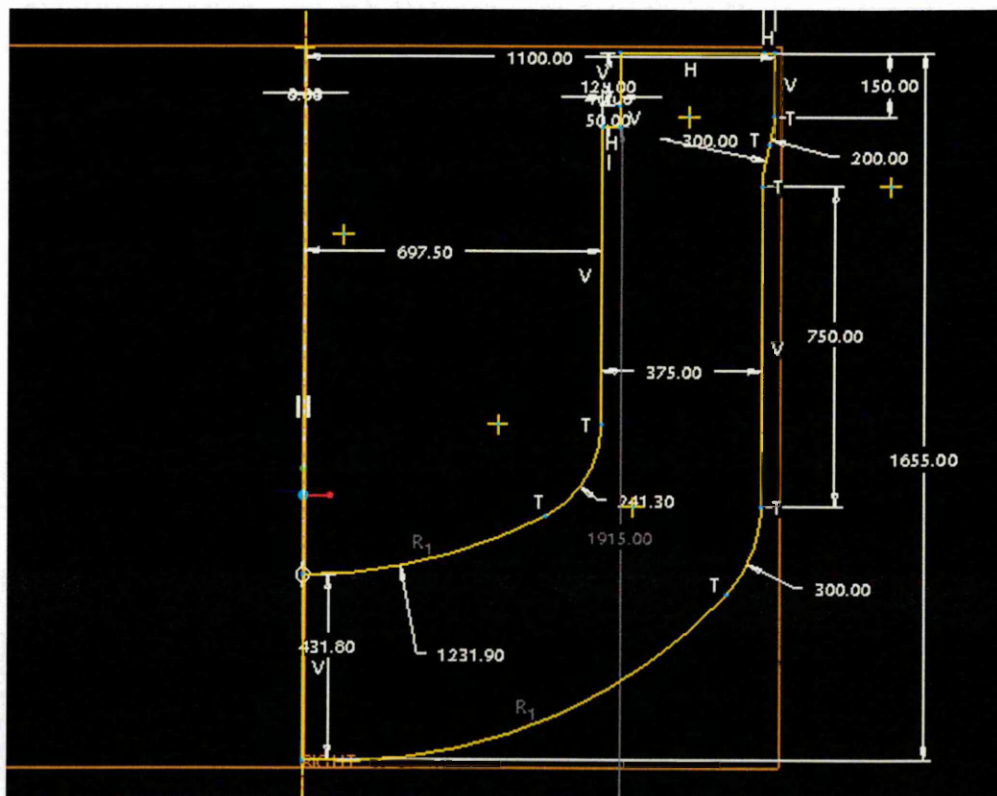

Figure 21: Cylinder Dimensions

5. Eliminates all the sharp corner areas, which results in easy access for assemble and dis-assemble the press.

5.8 FEA of Rubber Die Press

The crucial aspect for winning orders is to have a bespoke product design. Engineering business with advanced CAE techniques implemented will be capable of performing bespoke designs. In the development of Rubber Die Press and due to the size of the order the design of all the major components are carefully monitored and analysed to achieve the required output. For example, the design part of the hydraulic cylinder started in the pre-order stage itself because of its size and capacity.

5.8.1 Hydraulic Cylinder Analysis

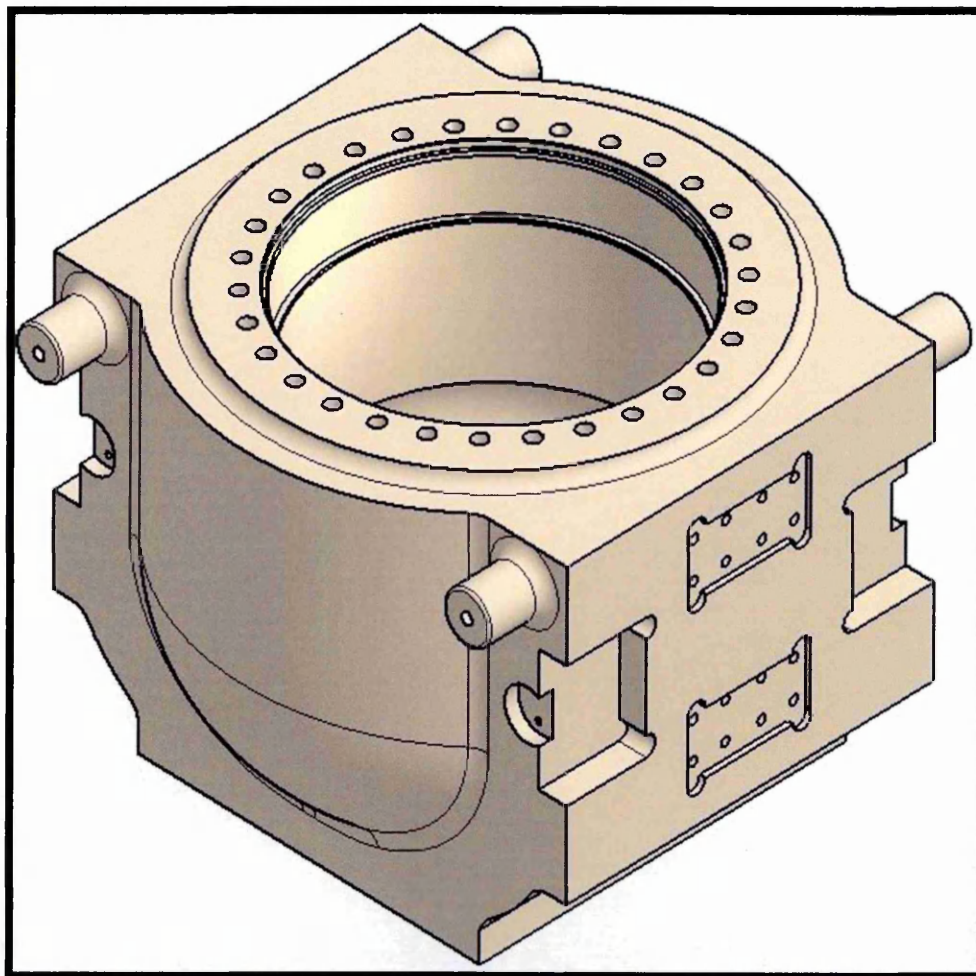

Figure 22: Rubber Die Press- Hydraulic cylinder

According to the initial specification, the cylinder needs to be fitted with a chevron packing and a steel gland held by studs and nuts. The cylinder itself has to have a long

bearing surface, inboard of the seals which ensure efficient lubrication of the ram within the cylinder at all times. The gland should contain wiper seal to return any excess oil retained on the ram surface during the stroke. In terms of the capacity, the machine should be 10000 tons or above to achieve the required outcome. Therefore by pressure calculation and stress levels, the cylinder has to withstand 700 bar of pressure with a total cast weight of approximately 40 ton.

In regards to the above requirements, the design team decided that the hydraulic cylinder needs to be approximately 2.2 m in diameter and 1.65 m in length made of cast steel in accordance with BS3100. The cylinder was then cautiously 3D modeled as show in the Figure 22 for various diameters from the basic design and stress analysed using computational finite element analysis to choose the correct size and shape.

5.8.1.1 Bursting Stress Calculation

The calculation is based on the capacity of the press and that is the only factor which determines how many cylinders are needed and the length, width and other dimensions of the press.

$$\begin{array}{l}
 \left. \begin{array}{l}
 1 \text{ Main Ram @ Diameter } 1350 \text{ mm} \\
 2 \text{ Side Ram @ Diameter } 200 \text{ mm}
 \end{array} \right\} \text{ Combined Area} \\
 \text{Capacity (Tonnage)} \qquad \qquad \qquad = \text{Pressure X Area} \\
 \qquad \qquad \qquad \qquad \qquad \qquad \qquad = 70 \times 1.53 \\
 \qquad \qquad \qquad \qquad \qquad \qquad \qquad = 107.07 \text{ MN}
 \end{array}$$

Capacity (Tonnage)	= 10,707 Ton
--------------------	--------------

$$\begin{aligned}
 \text{Bursting Stress } (\sigma_{Bs}) &= P \times \left[\frac{A^2 + B^2}{A^2 - B^2} \right] \\
 &= 70 \times \left[\frac{1.125^2 + 0.685^2}{1.125^2 - 0.685^2} \right]
 \end{aligned}$$

(σ_{Bs})	$= 152 \frac{MN}{M^2}$
-----------------	------------------------

Therefore,

Maximum Ram Diameter		= 1350 mm
Force Generated @ 700 bar	=100.20 MN	= 10020 Tonne
Force from 2 off 250 mm Diameter / Return rams	= 6.87 MN	=687 Tonne (+)
Weight of Moving Parts	= 0.35 MN	= 35 Tonne (-)
(Main Table, Rams and Plunger etc)		
Total Available Pressing Force	= 106.72 MN	= 10672 Tonne

5.8.1.2 Geometry and Mesh

The relevance settings listed in the below Table 6 and in Figure 23, controlled the fineness of the mesh used in this analysis. For reference, a setting of -100 produces a coarse mesh, fast solutions and results that may include significant uncertainty. A setting of +100 generates a fine mesh, longer solution times and the least uncertainty in results. Zero is the default Relevance setting. The setting used was based on several attempts looking at solution convergence.

Table 6: Hydraulic Cylinder Statistics

Bounding Box Dimensions	2250 mm
	1650 mm
	2190 mm
Part Mass	3.443e+004 kg
Part Volume	4.386e+009 mm ³
Mesh Relevance Setting	100
Nodes	437953
Elements	314046

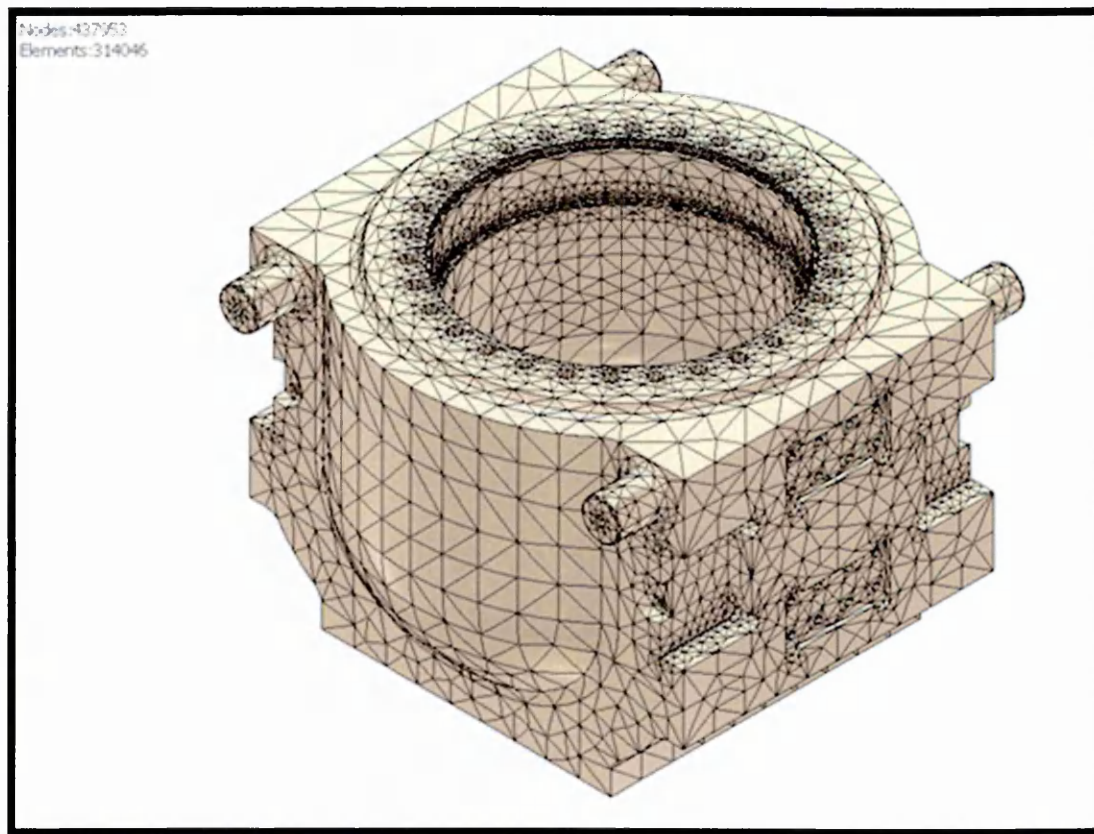

Figure 23: Hydraulic cylinder - Geometry and Mesh

Bounding box dimensions represent lengths in the global X, Y and Z directions

5.8.1.3 Material Properties and Assumptions

Table 7: Hydraulic cylinder - Material Properties: Cast Steel

Young's Modulus	2.1e+005 MPa
Poisson's Ratio	0.3
Mass Density	7.85e-006 kg/mm ³
Tensile Yield Strength	250.0 MPa
Tensile Ultimate Strength	300.0 MPa

The following material behavior assumptions apply to this analysis:

1. Linear - stress is directly proportional to strain.
2. Constant - all properties temperature-independent.
3. Homogeneous - properties do not change throughout the volume of the part.
4. Isotropic - material properties are identical in all directions.

5. Bottom and side ends are constrained
6. Hydraulic Seals are mounted

5.8.1.4 Loads and Constraint

The following loads and constraints act on specific regions of the part as shown on the Table 8 and Table 9 and in the Figure 24. Regions were defined by selecting surfaces, cylinders, edges or vertices.

Table 8: Hydraulic cylinder - Loads and Constraint Definitions

Load and Constraint Definitions			
Name	Type	Magnitude	Vector
Pressure 1	Surface Pressure	70.0 MPa	N/A
Fixed Constraint 1	Surface Fixed Constraint	0.0 mm	0.0 mm 0.0 mm 0.0 mm
Fixed Constraint 2	Surface Fixed Constraint	0.0 mm	0.0 mm 0.0 mm 0.0 mm

Table 9: Hydraulic cylinder - Constraint Reaction

Name	Force	Vector	Moment	Moment Vector
Fixed Constraint 1	5.721e+007 N	2.946e+004 N 5.721e+007 N -4803 N	4.115e+011 N·mm	1.58e+008 N·mm -3.338e+007 N·mm -4.115e+011 N·mm
Fixed Constraint 2	2.482e+007 N	-3.613e+004 N 2.482e+007 N 4803 N	2.272e+011 N·mm	6.345e+008 N·mm 4.365e+007 N·mm -2.272e+011 N·mm

Note: vector data corresponds to global X, Y and Z components.

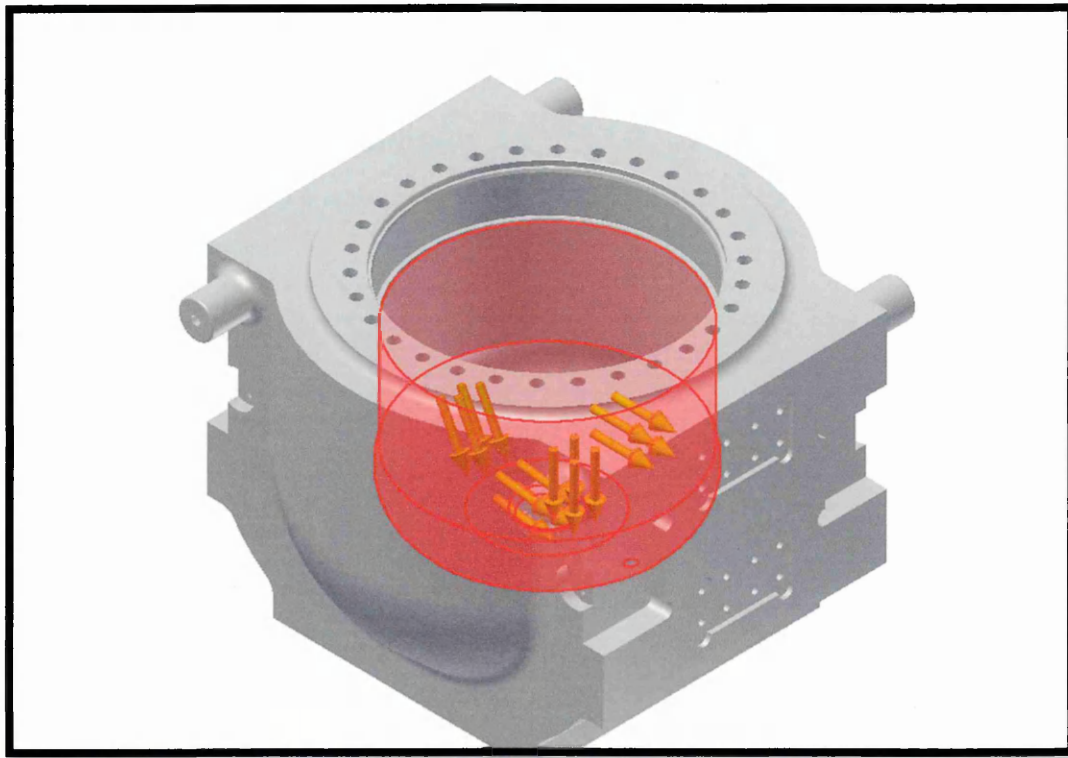

Figure 24: Hydraulic cylinder - Loads and Constraints

5.8.1.5 Results

Table 10 shows all structural results generated by the analysis. The following section provides Figure 25,26,27,28 and Figure 29 showing each result contoured over the surface of the part. Safety factor was calculated by using the maximum equivalent stress failure theory for ductile materials. The stress limit was specified by the tensile yield strength of the material.

Table 10: Hydraulic cylinder - Structural Results

Name	Minimum	Maximum
Equivalent Stress	9.994e-002 MPa	228.2 MPa
Maximum Principal Stress	-73.43 MPa	168.6 MPa
Minimum Principal Stress	-281.1 MPa	22.33 MPa
Deformation	0.0 mm	0.6709 mm
Safety Factor	1.096	N/A

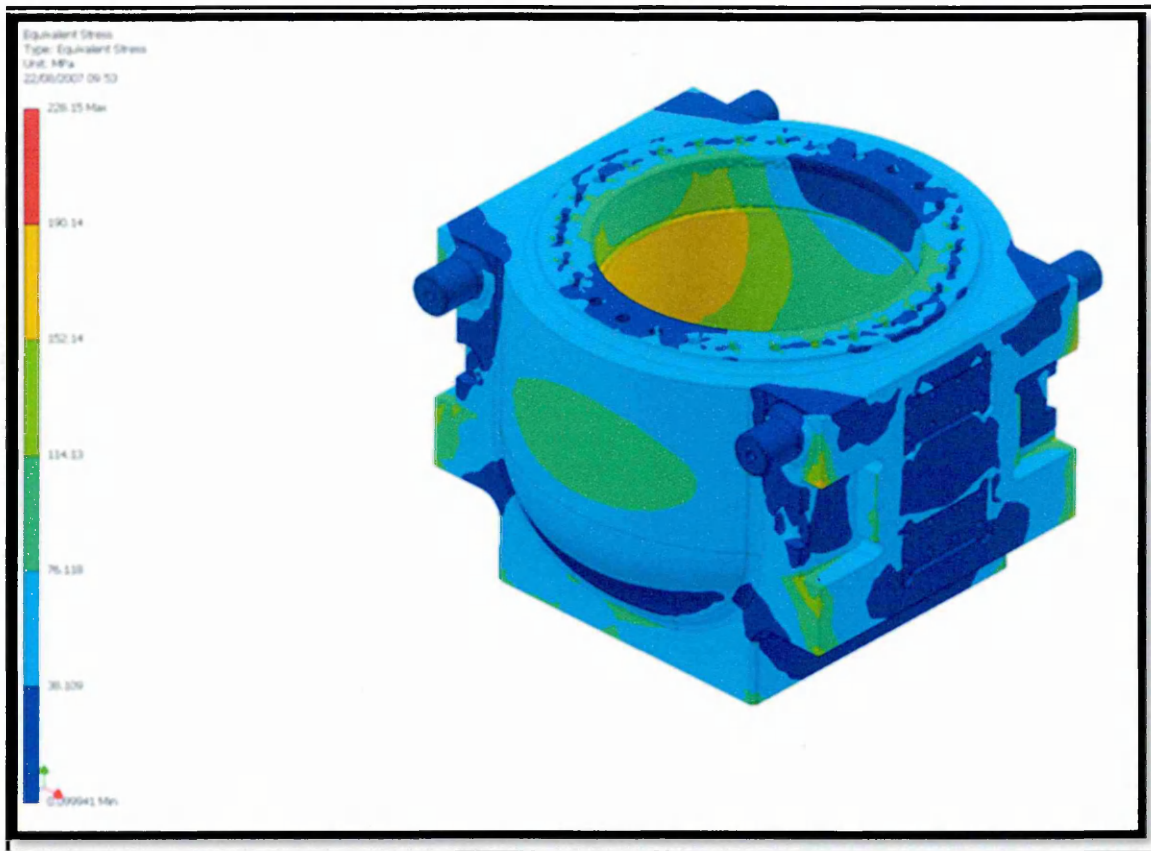

Figure 25: Hydraulic cylinder - Equivalent Stress

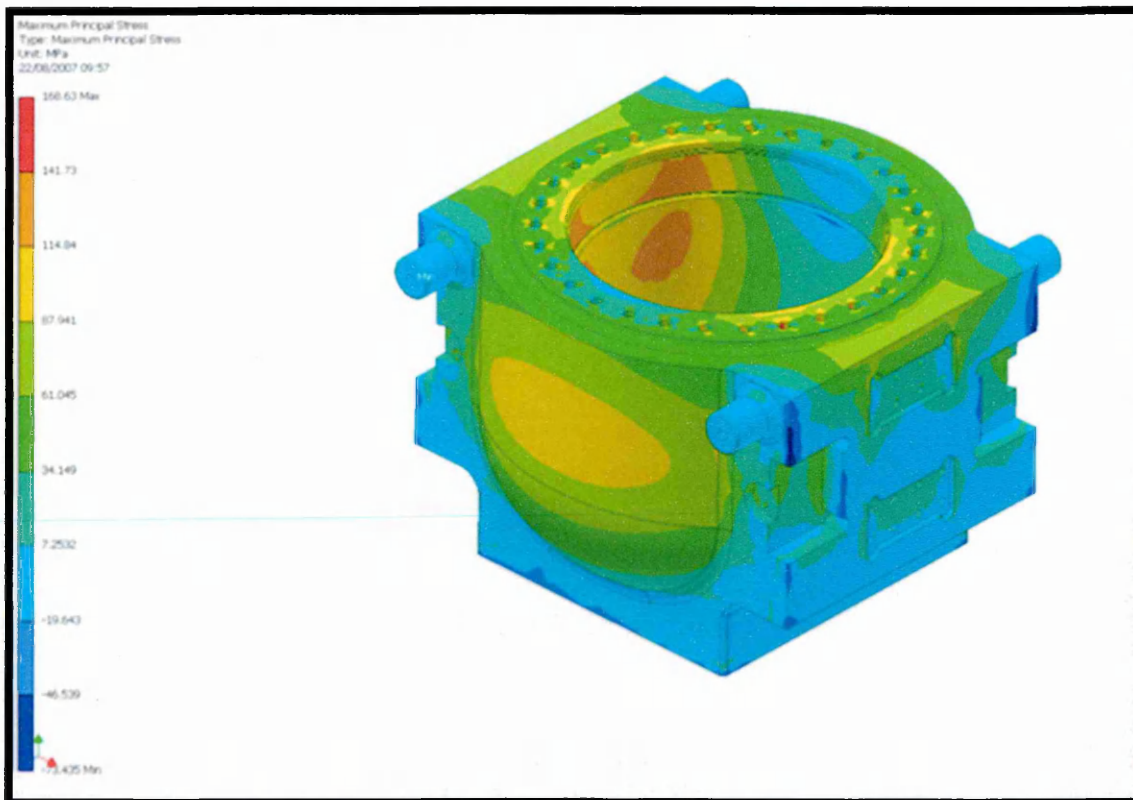

Figure 26: Hydraulic cylinder - Max. Principle Stress

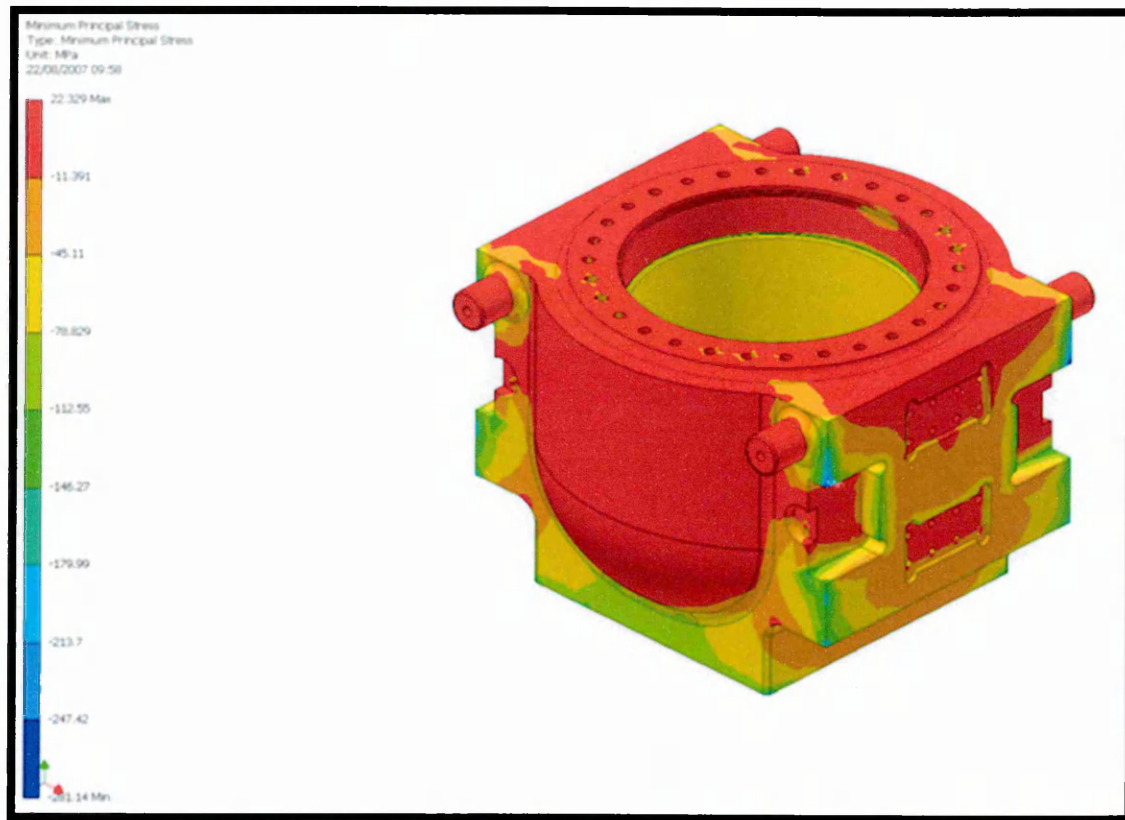

Figure 27: Hydraulic cylinder - Min. Principle Stress

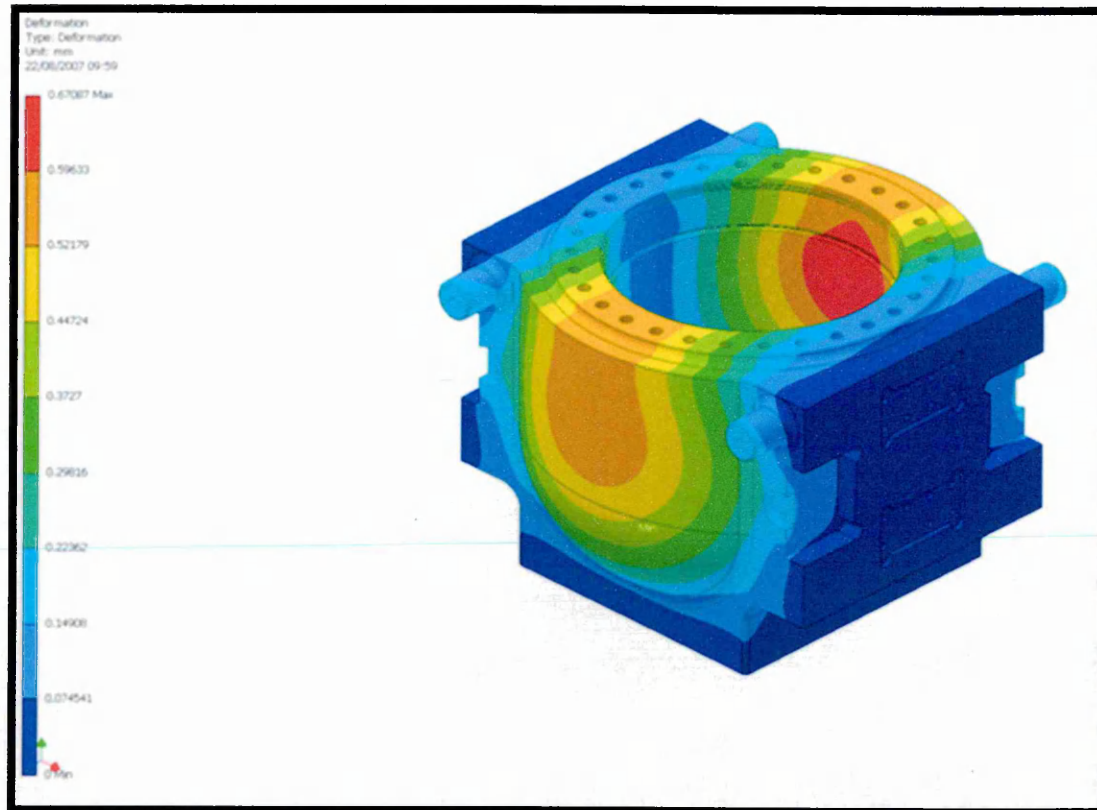

Figure 28: Hydraulic cylinder - Deformation

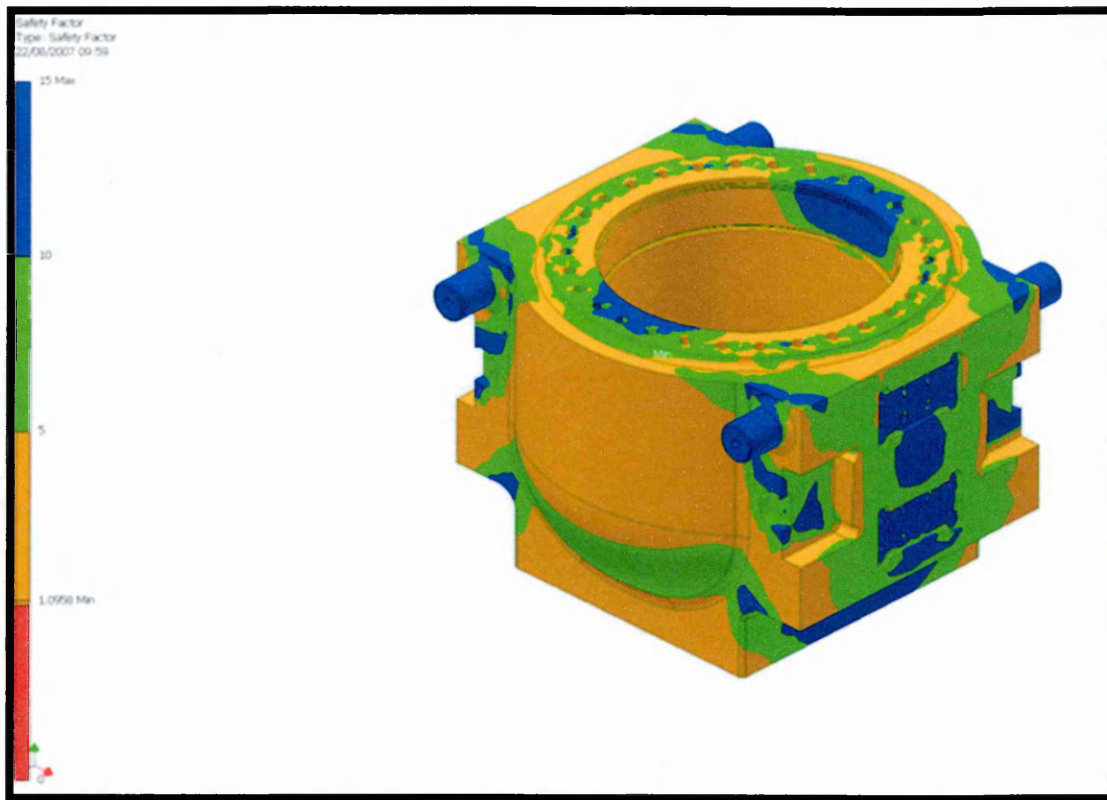

Figure 29: Hydraulic cylinder - Safety Factor

5.8.2 Frame Analysis

The Rubber Die Press frame comprises of a multi plate portal shaped steel structure with inner faces machined to align and secure the main cylinder and flexible pad holder within the frame. The eight frame plates (8000mm x 4000mm x 90mm) are separated by spacing rings and clamped together using tie rods horizontally to form a rigid frame (Figure 30).

Sourcing of the material and machining of the plates are the major mile stones to be considered during the initial stages of design. In relation to the size, the designer has to consider the readily available rolled plates which is mainly depends on length, width, and thickness.

The 3D model and analysis were carried out as similar to the hydraulic cylinder under the full rated load of 10000 ton on the bottom and top face where the hydraulic cylinder and rubber pad holder fits. Proper boundary conditions (likely scenarios) and material properties are to be applied to the plate in order to achieve appropriate sizes of the plate.

High Stress levels and high displacement areas such as corners with smaller radius, lifting holes near the loading area are thoroughly studied by repeated stress analysis. The stress analysis levels are compared with the industry standard stresses and deflection levels which is 5 tons/sq.in and 1mm per 1000mm.

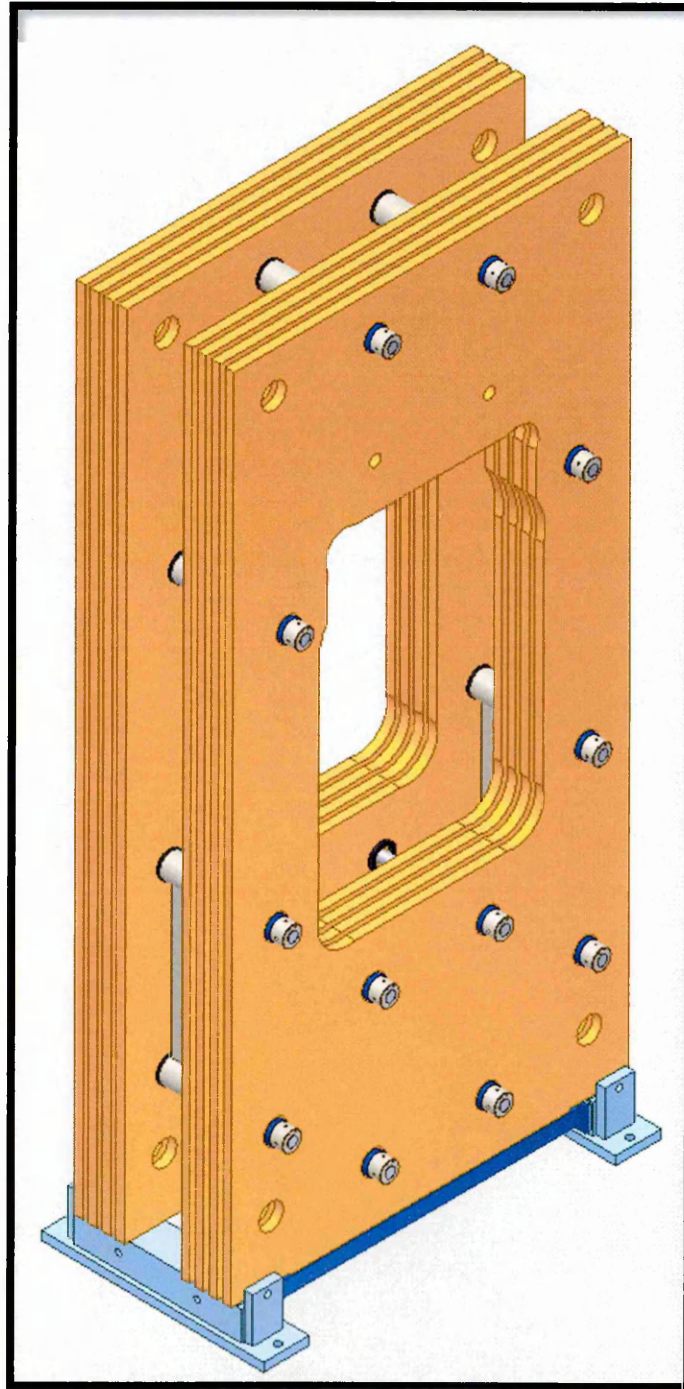

Figure 30: Rubber Die Press - Press frame

5.8.2.1 Geometry and Mesh



Figure 31: Frame plate - Geometry and Mesh

The relevance settings listed in the below Figure 31 and in the Table 11, controlled the fineness of the mesh used in this analysis. The setting used was based on several attempts looking at solution convergence.

Table 11: Frame Plate Statistics

Bounding Box Dimensions	4000 mm 8000 mm 90.0 mm
Part Mass	1.666e-005 kg
Part Volume	2.136e+009 mm ³
Mesh Relevance Setting	0
Nodes	2684
Elements	319

Bounding box dimensions represent lengths in the global X, Y and Z directions.

5.8.2.2 Material Properties

Table 12: Frame plate - Material Properties: EN 50 B

Young's Modulus	2.1e+005 MPa
Poisson's Ratio	0.29
Mass Density	7.8e-015 kg/mm ³
Tensile Yield Strength	355.0 MPa
Tensile Ultimate Strength	470.0/630.0 MPa

The following material behavior assumptions apply to this analysis:

1. Linear - stress is directly proportional to strain.
2. Constant - all properties temperature-independent.
3. Homogeneous - properties do not change throughout the volume of the part.
4. Isotropic - material properties are identical in all directions.

5.8.2.3 Loads and Constraints

The following loads and constraints (Table 13 and Table 14) act on specific regions of the part. Regions were defined by selecting surfaces, cylinders, edges or vertices.

Table 13: Frame plate - Load and Constraint definition

Name	Type	Magnitude	Vector
Force 1	Surface Force	1.308e+007 N	-2.144e-007 N -1.308e+007 N 0.0 N
Force 2	Surface Force	1.308e+007 N	2.15e-007 N 1.308e+007 N 0.0 N
Fixed Constraint 1	Surface Fixed Constraint	0.0 mm	0.0 mm 0.0 mm 0.0 mm

Table 14: Frame plate - Constraint Reaction

Name	Force	Vector	Moment	Moment Vector
Fixed Constraint 1	1.353e-003 N	8.952e-007 N 1.353e-003 N 3.485e-006 N	8.263e+005 N·mm	-326.5 N·mm -0.4128 N·mm 8.263e+005 N·mm

Note: vector data corresponds to global X, Y and Z components.

5.8.2.4 Results

Table 15 provides Figure 32,33,34,35 and 36 showing each result contoured over the surface of the part. Safety factor was calculated by using the maximum equivalent stress failure theory for ductile materials. The stress limit was specified by the tensile yield strength of the material.

Table 15: Frame plate - Structural Results

Name	Minimum	Maximum
Equivalent Stress	2.96 MPa	207.0 MPa
Maximum Principal Stress	-2.599 MPa	222.2 MPa
Minimum Principal Stress	-117.8 MPa	8.718 MPa
Deformation	0.0 mm	2.984 mm
Safety Factor	1.715	N/A

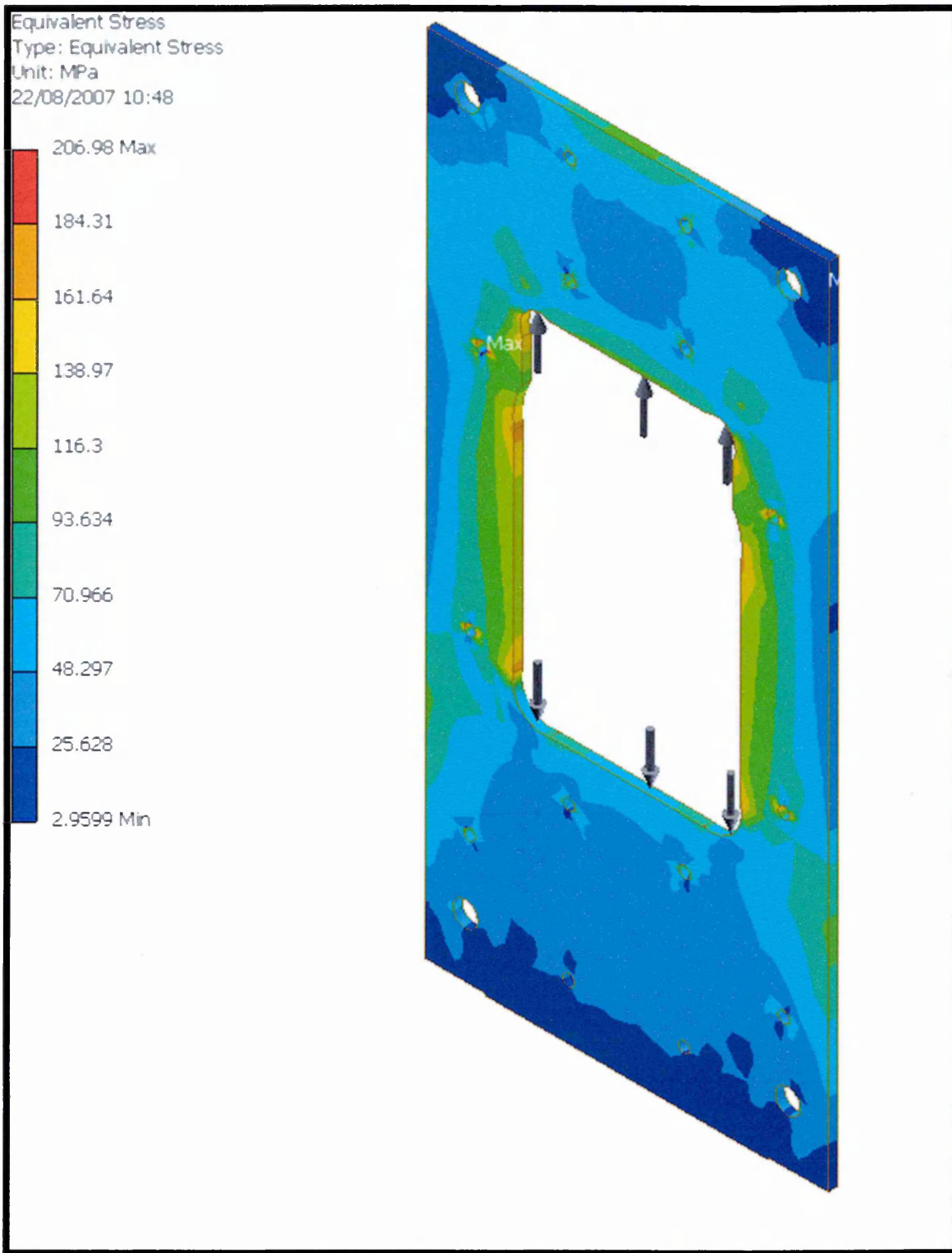

Figure 32: Frame plate - Equivalent Stress

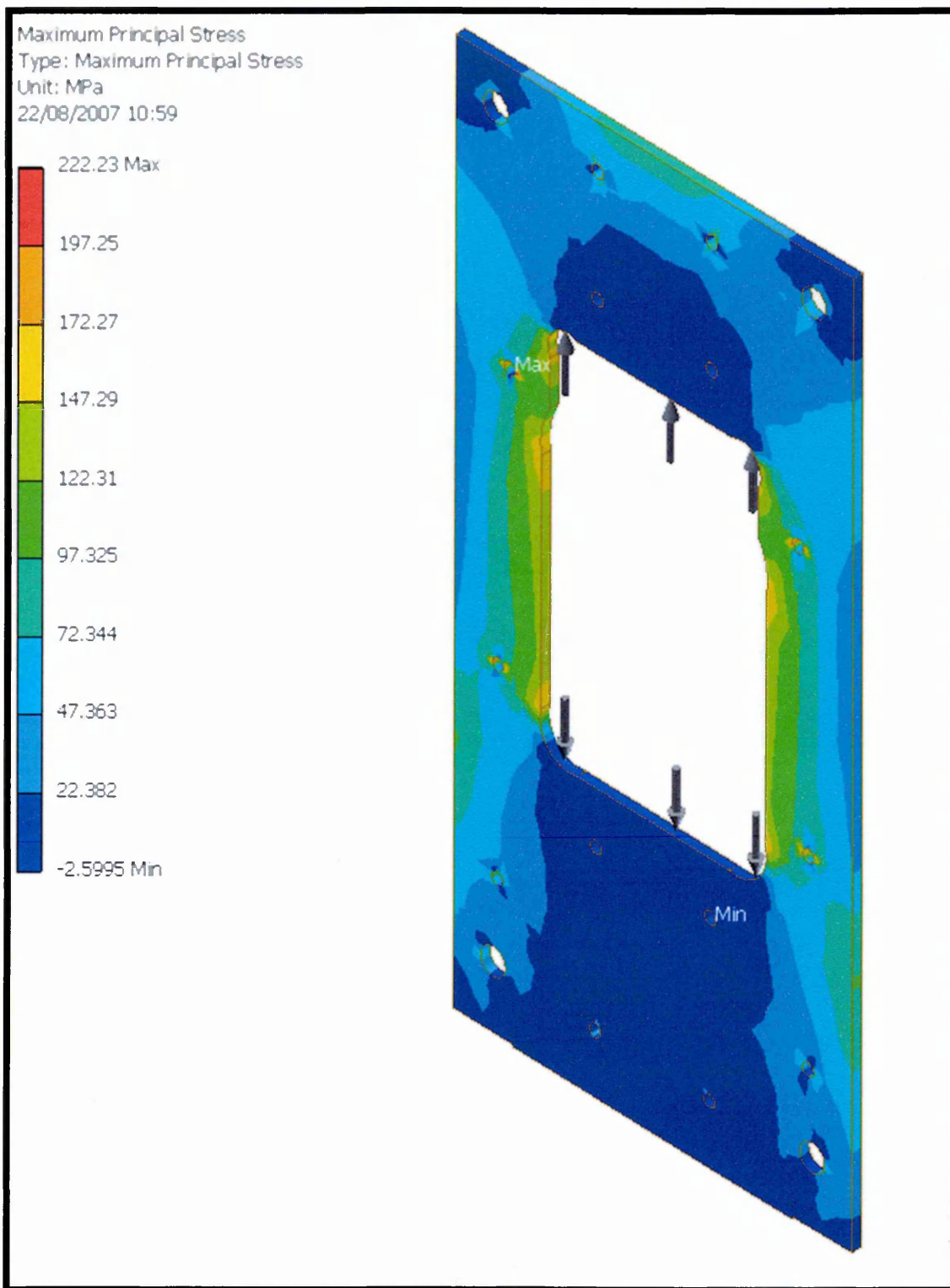

Figure 33: Frame plate - Max. Principle Stress

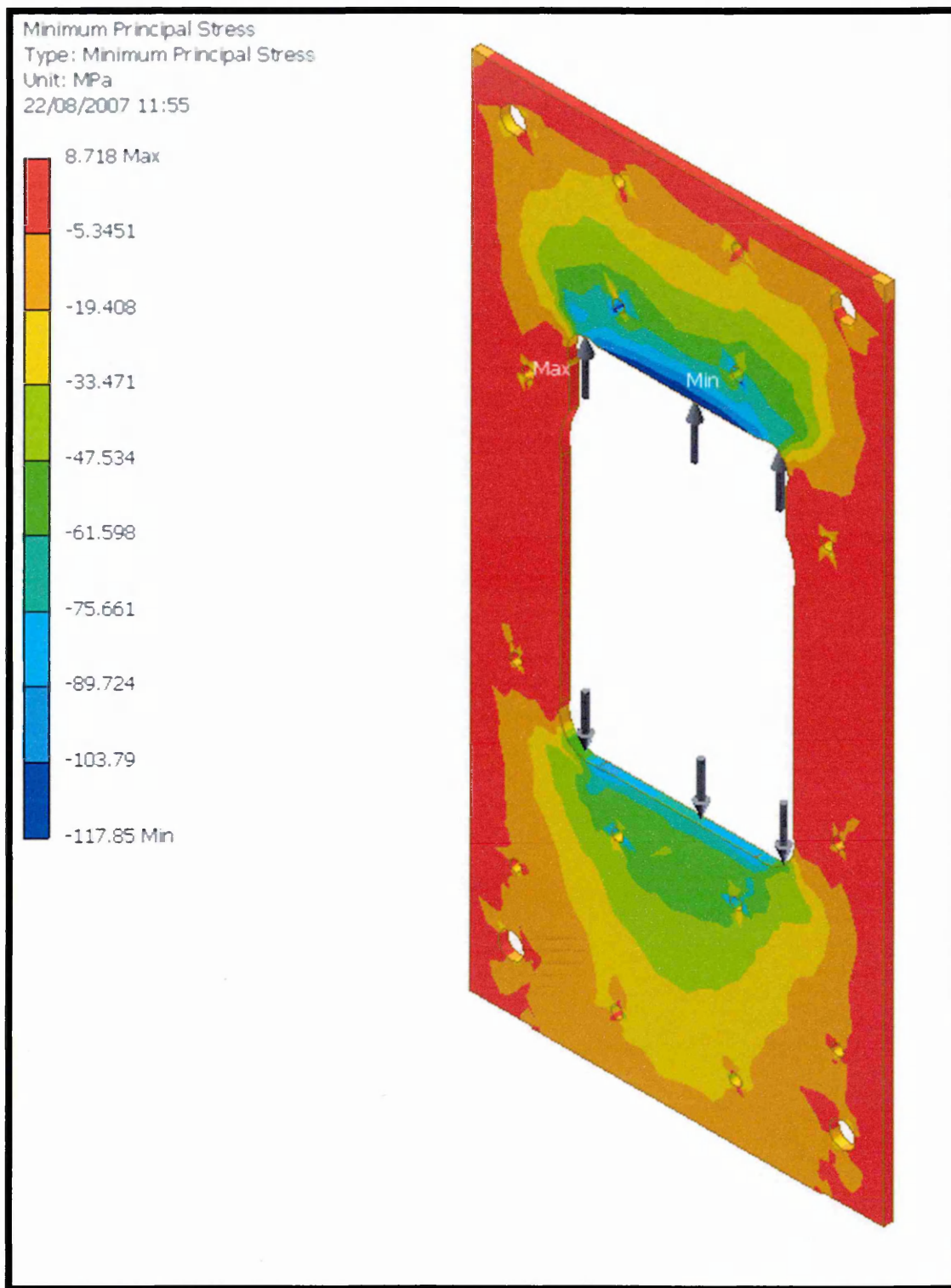

Figure 34: Frame plate - Min. Principle Stress

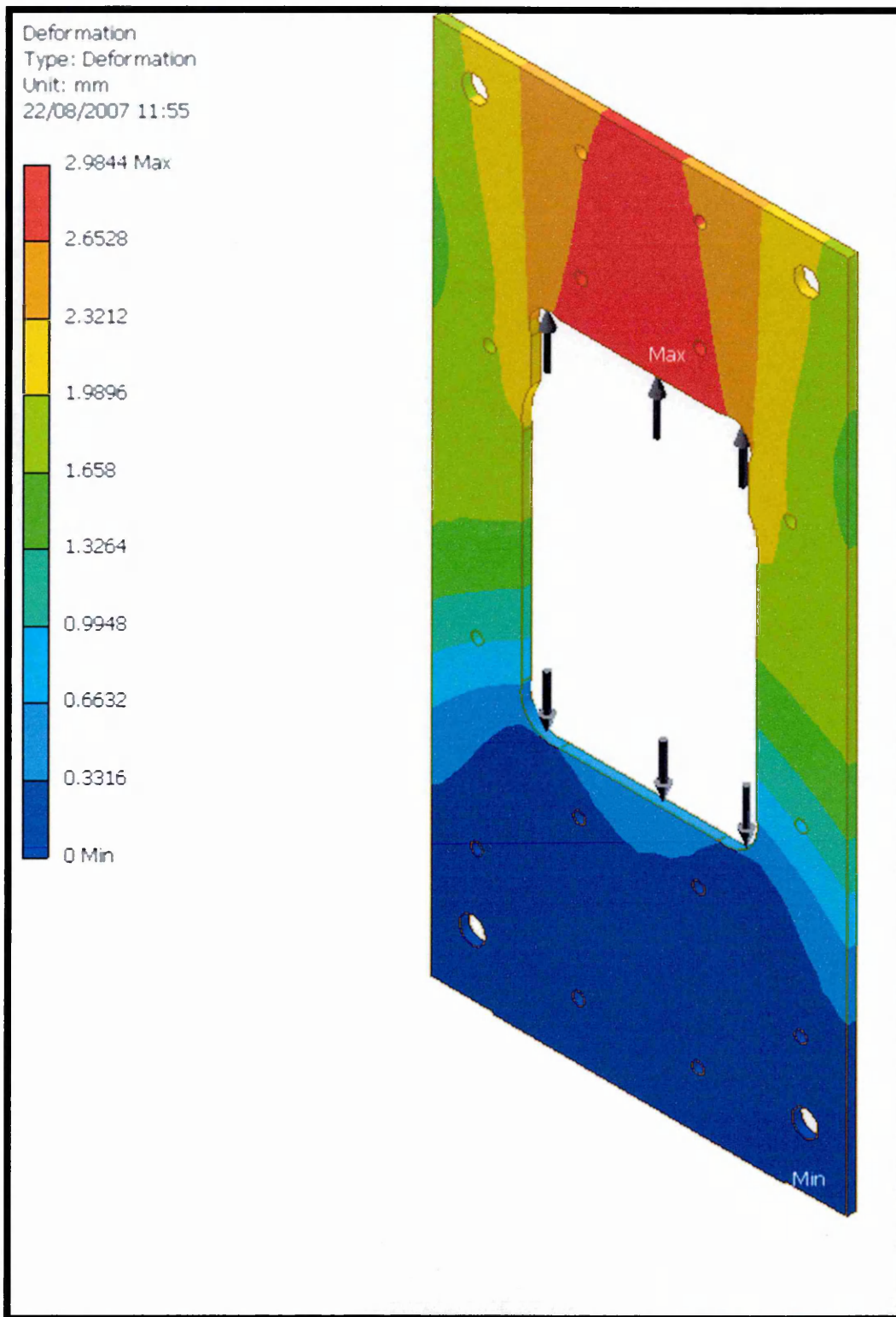

Figure 35: Frame plate - Deformation

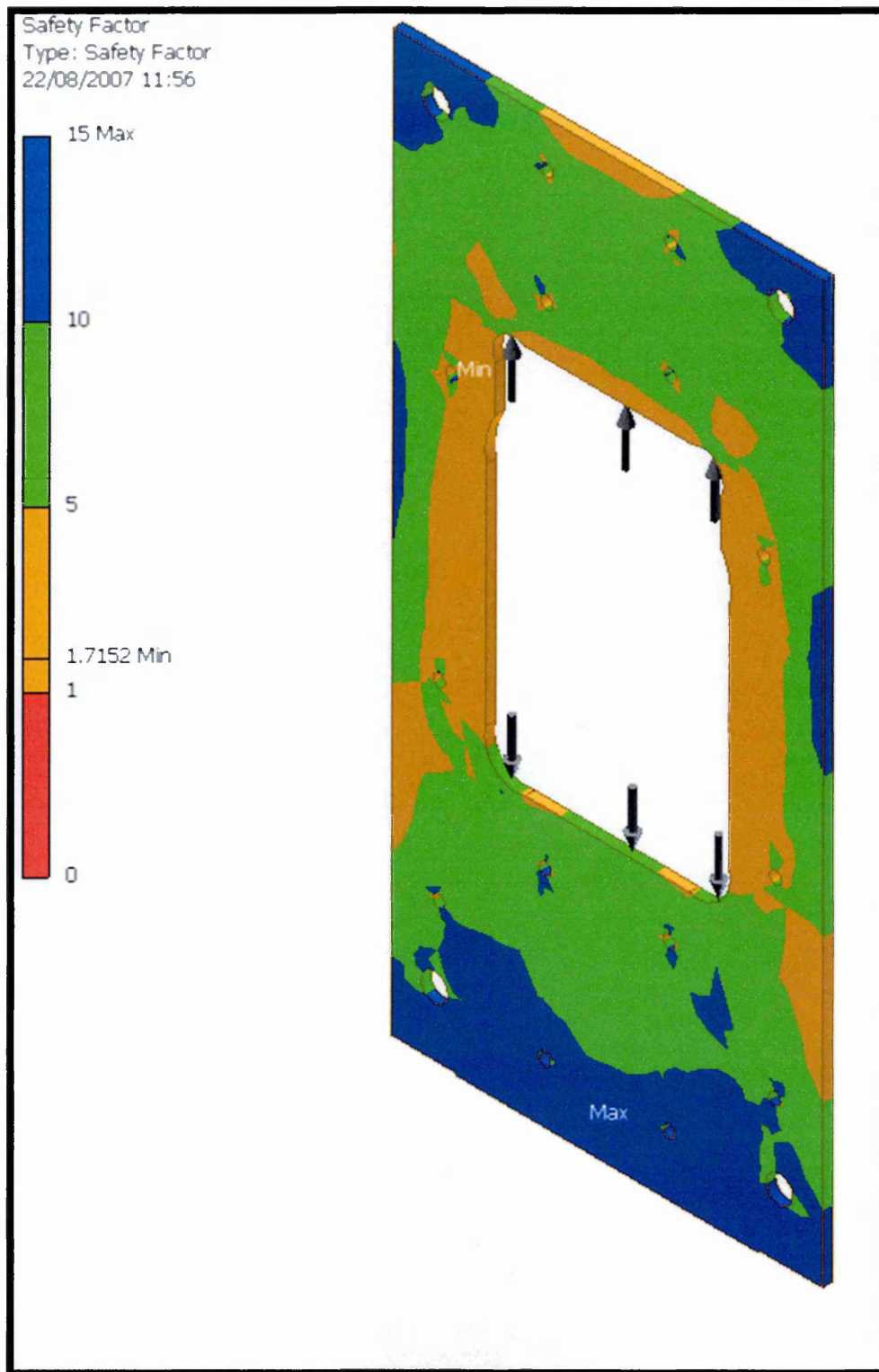

Figure 36: Frame plate - Safety Factor

5.8.3 Rubber Pad Holder Analysis

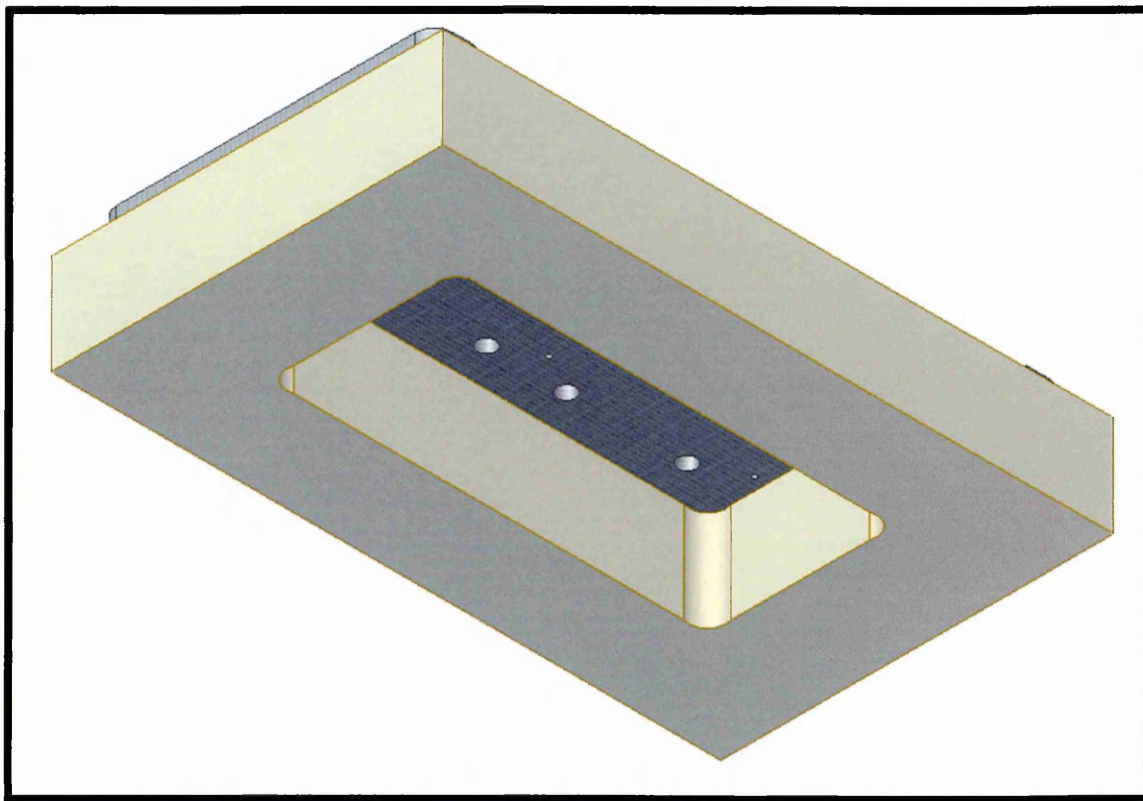

Figure 37: Rubber Die Press - Pad holder with backing plate

The Pad Holder as shown on the above Figure 37 plays an important role in the rubber die press development. It is the container which holds the natural rubber firmly and positions the top for an up-stroking press. The pad holder should be a fabricated steel structure, of 'Picture Frame' design, stress relieved prior to machining, faced on upper and lower sides. Also the design has to incorporate tapped holes on the underside by which it is bolted and located to the backing plate, in which the rubber is moulded by means of locating pins. These location pins picking up tooling holes for attachment of the blank to the die are well spaced and not near any bending radius. The vital part of the design is the extraction of rubber from the pad holder in certain time limits and that can only be achieved by having hydraulic jack-our cylinders.

After considering the above mentioned limitations in designing the pad holder the design started by looking at corner radius and thickness of the pad. As described in the Blank

Holder Effect, the depth of the pad should be at least ¼ inch deeper than the flange which is to be formed on the component, so the bigger the depth of the component, the bigger the pad holder thickness.

By considering the maximum tool depth and suitable material, the pad holder is subjected to surface pressure under finite element stress analysis. In regards to 10600 tonne press, maximum of 454 bar pressure applied to the pad surface in intervals.

5.8.3.1 Calculation

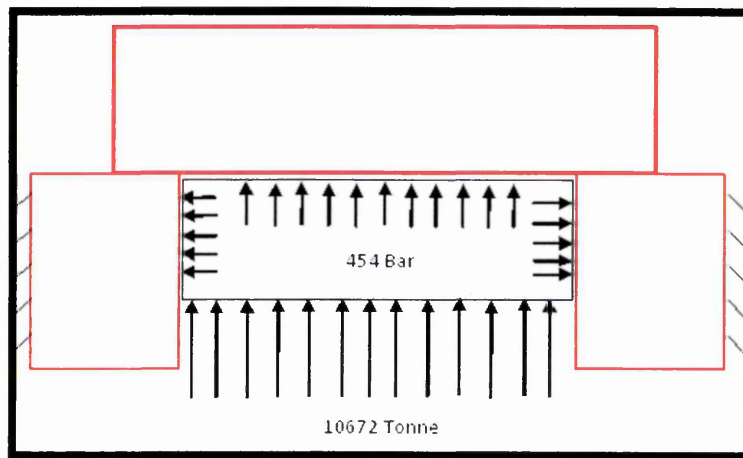

Figure 38: Pad holder - Load schematics

When Load is applied as shown on Figure 38, the rubber will be displaced 0.3 - 0.5 mm gap around the sides of the pad holder and also compress its volume.

$$\text{Volume of rubber} = (2.350 \times 1 \times 0.36) = 0.84645 \text{ Cubic meters}$$

Assume 1% compression per 100 Bar

$$= 360 \times 0.01 \times (454/100) = 16.34 \text{ mm compression}$$

Since the separation force is very high, Welding is needed between the pad holder and cover plate to overcome the separation force

$$\begin{aligned} \text{Pressure} &= \text{Load/Area} \\ &= 106 \text{ MN} / (1 \times 2.350) = 451 \text{ Bar} \end{aligned}$$

$$\begin{aligned} \text{Separating Force} &= \text{Pressure} \times \text{Area} \\ &= 45100 \text{ KN/m}^2 \times (0.994 \times 0.36) \text{ m} \\ &= 16138.584 \text{ KN} \end{aligned}$$

$$= 1613.5858 \text{ Tonne}$$

Coefficient of friction (Rubber on steel) = 1.6

Therefore = $1613.858 \times 1.6 = 2582.17 \text{ Tonne}$

$$= 25.82 \text{ MN}$$

For rubber compression, Assume 1% per 100 Bar,

Therefore 4.54 % for 454 Bar

For 360 mm deep rubber pad @ 4.54 % of compression is 16.34 mm

5.8.3.2 Geometry and Mesh

The Mesh is the finite element analysis template of the model are explained in the Table 16. The following are included

1. Well shaped elements (i.e., as little distortion of elements as possible-Equivalent triangles and square are ideal)
2. The transition between densities should be smooth and gradual without distortion of elements. This scenario happens around stress riser areas

Table 16: Pad holder Statistics

Bounding Box Dimensions	3450 mm 2100 mm 535 mm
Part Mass	N/A
Part Volume	N/A
Mesh Relevance Setting	0
Nodes	9783
Elements	4256

5.8.3.3 Material Properties and Assumptions

Table 17: Pad holder - Material Properties: EN 50B

Young's Modulus	2.1e+005 MPa
Poisson's Ratio	0.29
Mass Density	7.8e-015 kg/mm ³
Tensile Yield Strength	355.0 MPa
Tensile Ultimate Strength	470.0/630.0 MPa

1. Constrained on both ends and top of the backing plate
2. Backing plate and pad holder as a homogeneous material
3. Surface pressure of 450 Bar exerted by the rubber pad is acting on all 4 sides.

5.8.3.4 Boundary Conditions

Boundary conditions include loads and constraints. Loads are applied over a pre-selected geometry and constraints restrict specific degrees of freedom of predetermined areas of part. Boundary conditions are probably the largest representation of assumptions in FEA. Over constraining or under constraining a system will affect the accuracy of the results.

Pressure 1	Surface Pressure	45.0 MPa	N/A
------------	------------------	----------	-----

5.8.3.5 Results

Table 18, shows all structural results generated by the analysis. The following section provides Figure 39, 40, and 41 showing each result contoured over the surface of the part. Safety factor was calculated by using the maximum equivalent stress failure theory for ductile materials. The stress limit was specified by the tensile yield strength of the material.

Table 18: Pad holder - Structural Results

Name	Minimum	Maximum
Equivalent Stress	0.2 MPa	187 MPa
Deformation	0.0 mm	1.429 mm
Safety Factor	1.715	N/A

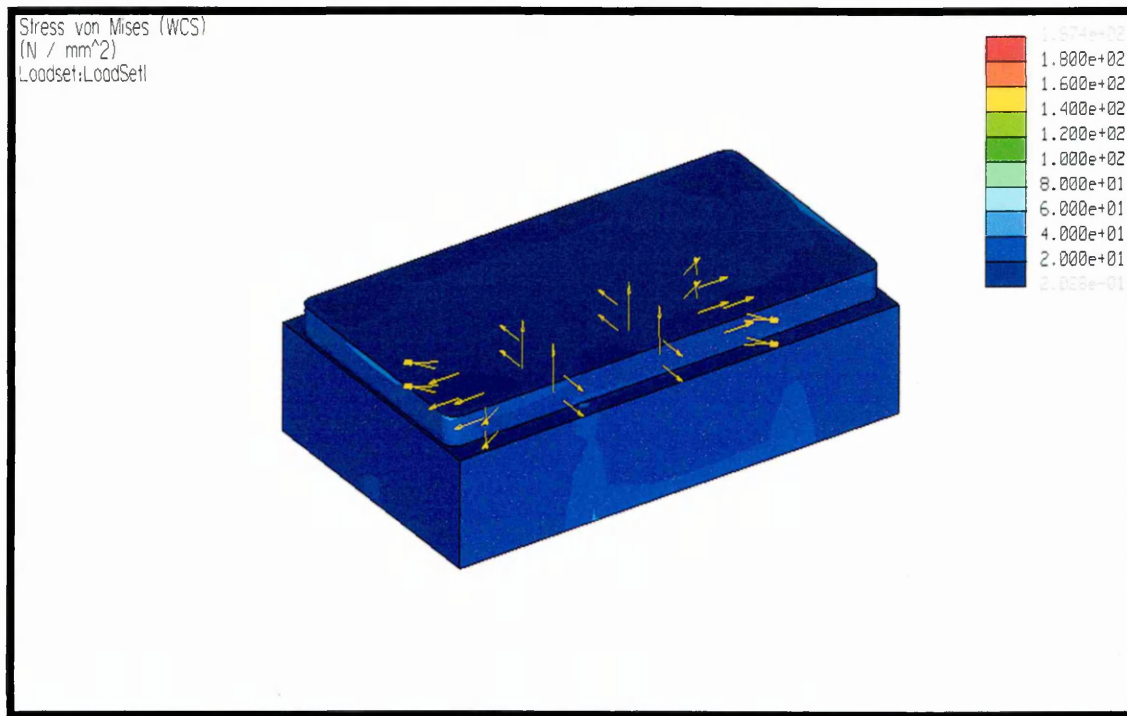

Figure 39: Pad holder - Equivalent Stress -View 1

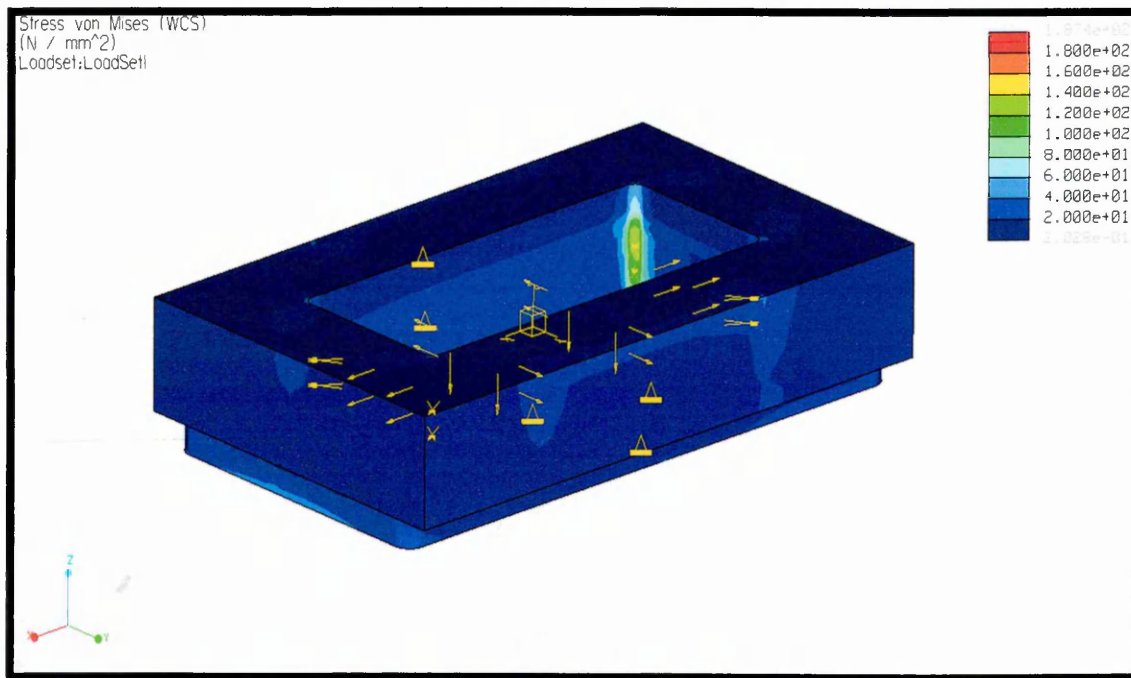

Figure 40: Pad holder - Equivalent Stress -View 2

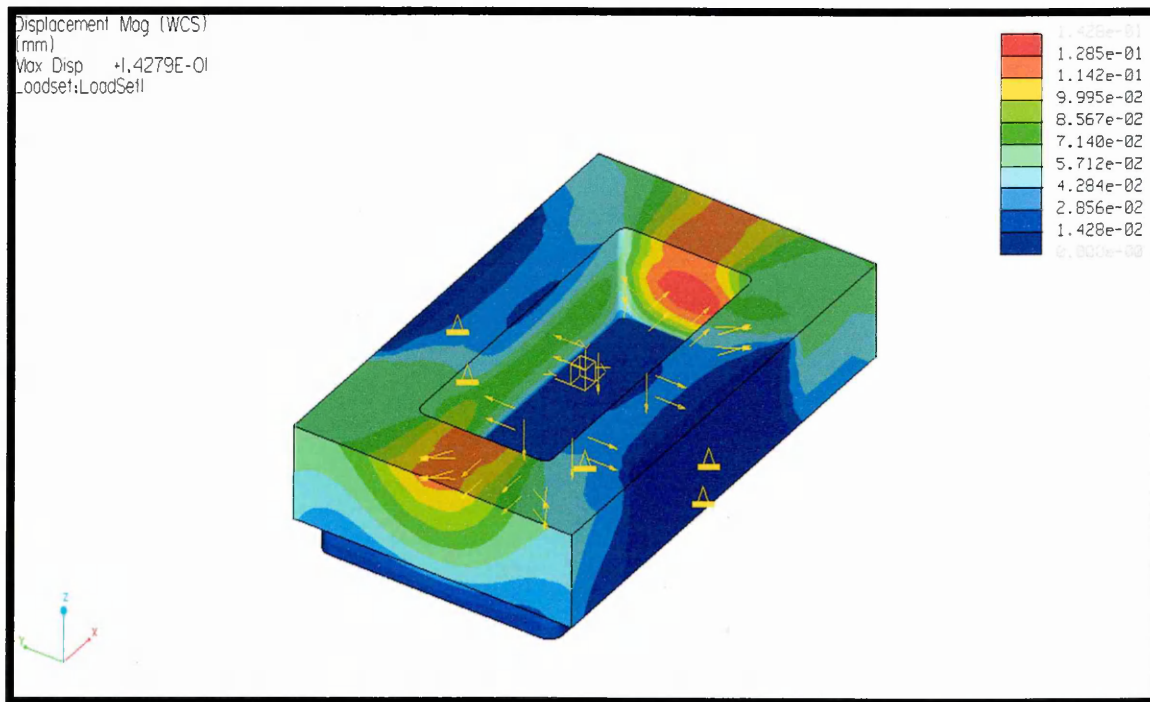

Figure 41: Pad holder - Deformation

5.8.4 Moving Table Analysis

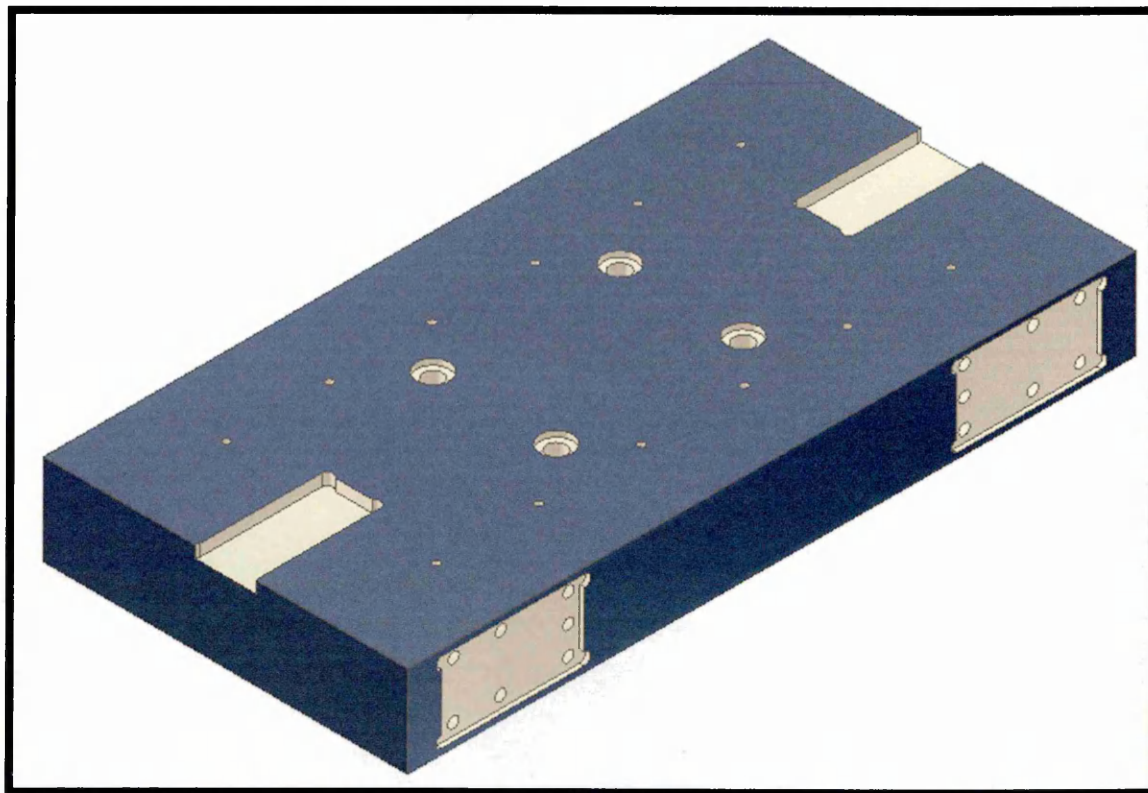

Figure 42: Rubber Die Press - Moving table

The moving table as shown in Figure 42 should be a one piece steel slab, faced and tapped on the upper and lower surfaces to locate and secure the plunger plate, main and side ram retaining clips. The corners of the table are stepped, machined and tapped to accept the detachable table guides.

The plunger plate is a steel plate machined all over, with central guide slot and bored to house several protruding spring loaded rollers to align and support drawplate respectively. Also it should be bolted rigidly to top face of moving table and bored in 4 – places to house bolts clamping table to main piston.

In respect to the draw tables, it needs to be fitted to front and rear of press respectively used for manually loading tools on to drawplate and feeding into press tool space. The draw tables can be programmed to operate individually or in alternating cycles to maximize component production. Each draw table comprises of a fabricated steel box section frame rigidly bolted to press frame to ensure alignment when traversing drawplate. Fixed wheel-style rollers are housed in brackets which mount on top of the frame. The rollers locate in slots in the underside of the drawplate is to support and guide the drawplate as it traverses into the press tool space. A loading arm attaches the drawplate to the actuator which in turn is powered by a geared motor unit with a flexible coupling/overload clutch fitted to protect the system.

When the drawplate is fully docked in the tool space, micro switches sequence a locking pin to engage with the loading arm on the drawplate to ensure alignment between drawplate and pad holder. With the locking pin fully engaged micro switches signal the press to stroke. When the press completes a full stroke a reversal of the previous sequence traverses the drawplate back out to its home position ready for re-tooling.

5.8.5 Calculation

5.8.5.1 Geometry and Mesh

The Mesh is the finite element analysis template of the model as described in Table 19 .

The following are included

1. Well shaped elements (i.e. as little distortion of elements as possible-Equivalent triangles and square are ideal)
2. The transition between densities should be smooth and gradual without distortion of elements. This scenario happens around stress riser areas

Table 19: Moving table Statistics

Bounding Box Dimensions	3100 mm 1575 mm 390 mm
Part Mass	N/A
Part Volume	N/A
Mesh Relevance Setting	0
Nodes	15830
Elements	7265

5.8.5.3 Material Properties and Assumptions

Table 20: Pad holder - Material Properties: EN 50B

Young's Modulus	2.1e+005 MPa
Poisson's Ratio	0.29
Mass Density	7.8e-015 kg/mm ³
Tensile Yield Strength	355.0 MPa
Tensile Ultimate Strength	470.0/630.0 MPa

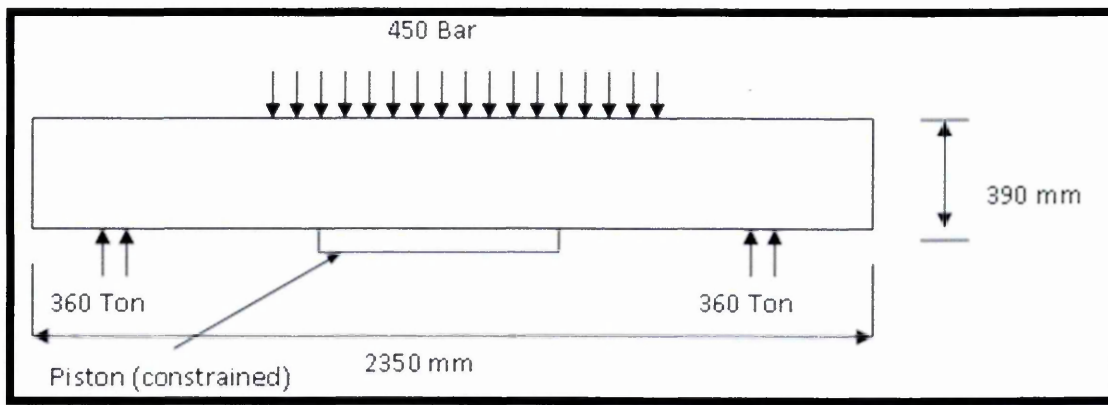

Figure 43: Moving Table - Load schematics

The above Figure 43 explains the following:

1. Constrained on both ends.
2. No plunger plate on the top of the table.
3. Surface pressure of 454 Bar is acting directly on the table. (Cross Section of pad area 2350 x 990 mm)
4. Piston end constrained.

5.8.5.4 Boundary Conditions

Boundary conditions shown on Table 21 and Table 10 shows all structural results generated by the analysis. The following section provides Figure 44, 45, 46 and 47 showing each result contoured over the surface of the part. Safety factor was calculated by using the maximum equivalent stress failure theory for ductile materials. The stress limit was specified by the tensile yield strength of the material.

Table 22; include loads, constraints and results. Loads are applied over a pre-selected geometry and constraints restrict specific degrees of freedom of predetermined areas of the part.

Boundary conditions are probably the largest representation of assumptions in FEA. Over constraining or under constraining a system will affect the accuracy of the results.

Table 21: Moving Table: Boundary Conditions

Force 1	Surface Force	3.53e+006 N	0.0 N 0.0 N 3.53e+006 N
Pressure 1	Surface Pressure	45.0 MPa	N/A

5.8.5.5 Results

Table 10 shows all structural results generated by the analysis. The following section provides Figure 44, 45, 46 and 47 showing each result contoured over the surface of the part. Safety factor was calculated by using the maximum equivalent stress failure theory for ductile materials. The stress limit was specified by the tensile yield strength of the material.

Table 22: Moving Table - Structural Results

Name	Minimum	Maximum
Equivalent Stress	0.2 MPa	298 MPa
Deformation	0.0 mm	1.109 mm
Safety Factor	1.915	N/A

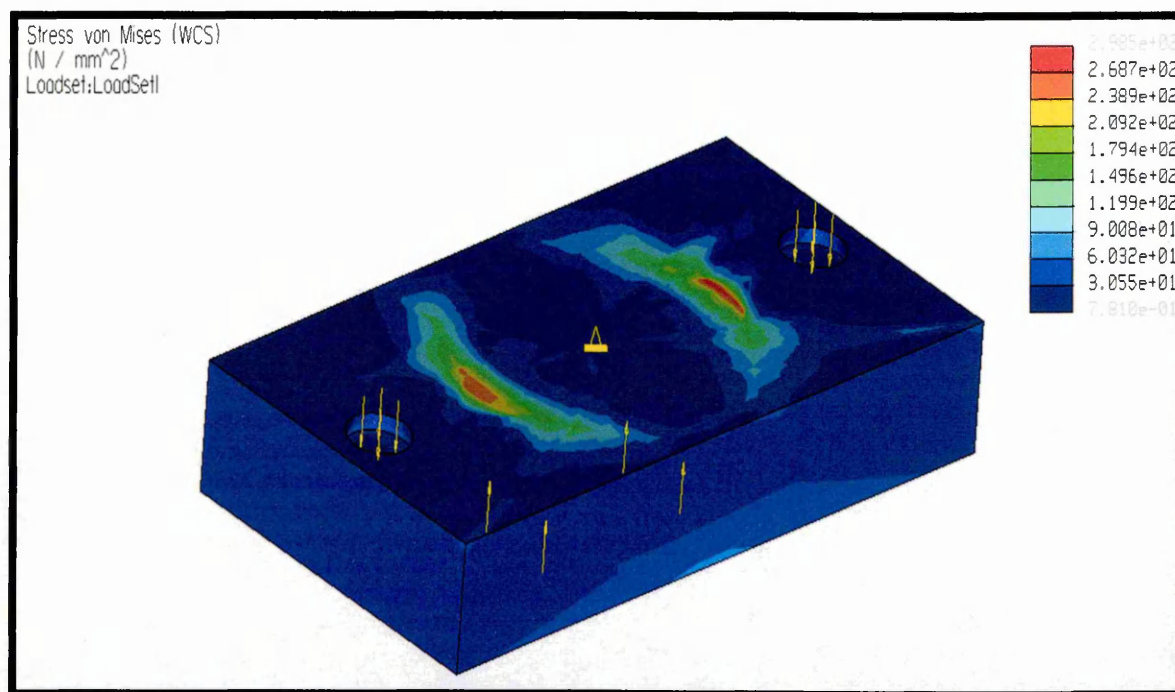
**Figure 44: Moving table: Equivalent Stress - View 1**

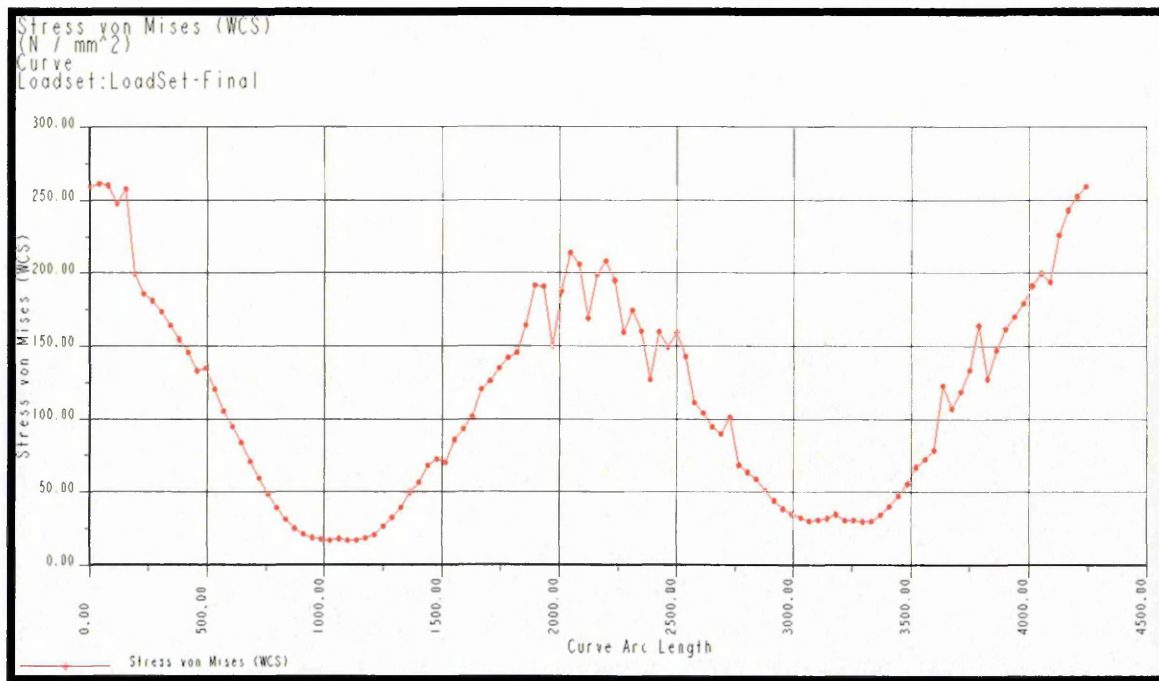

Figure 45: Moving table - Load distribution curve across piston circumference

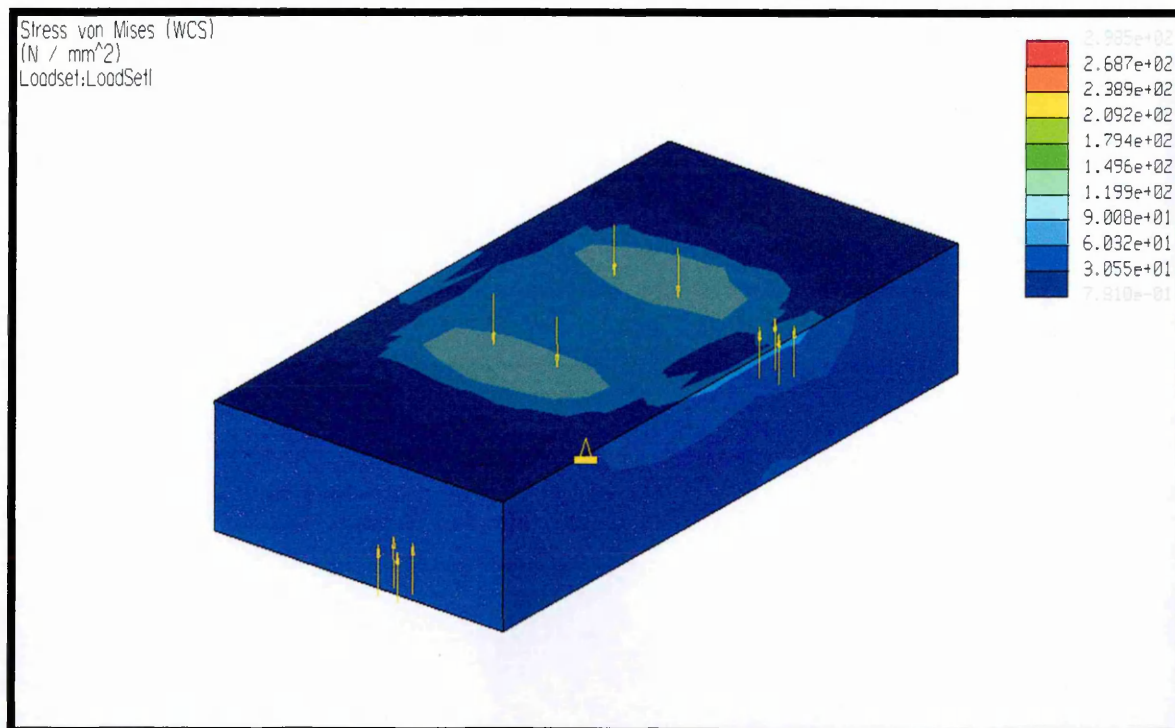

Figure 46: Moving table: Equivalent Stress - View 2

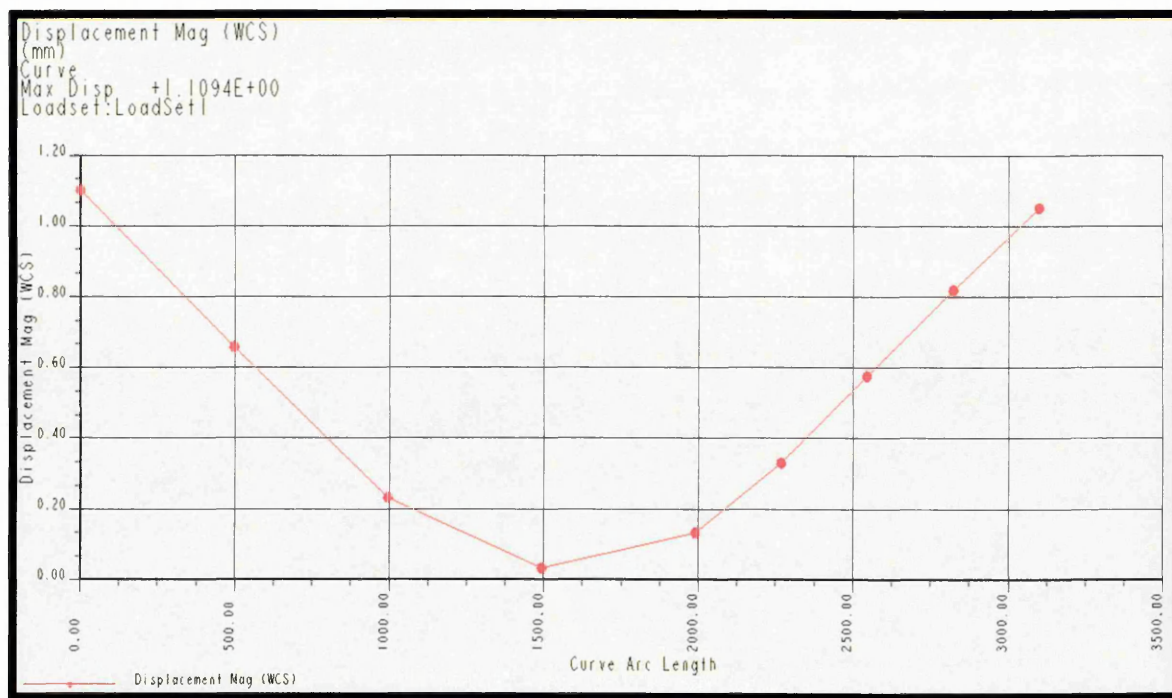

Figure 47: Moving table - Displacement distribution curve across piston circumference

5.8.6 Benefits of FEA

As described in the Chapter 4 -Section 4.4.2.1, Finite Element Analysis is a computer based simulation technique used to analyse the structure and describe the behaviour of the structure under various possible load cases and boundary conditions.

After CAE Implementation in Joseph Rhodes Limited, It was decided to perform FEA on the rubber die press components in order to understand the software and its behaviour. The software performed in perfection and by repeated correction the designer eliminated major stress and deflection areas in the press. This gave the designer a huge confidence in the design and to reduce the unwanted material in the press. In reference to the section 5.6.2 the actual software cost about £7400 in 2008 and about 45 tonne of material in the side plates and main cylinder was saved. Thus £7,400 investment has produced benefits of £48,000 as explained in table 4, which is 4.8% savings in a £1 million contract and with a Rate of Return = $((48000-7400/7400) \times 100) = 548.64 \%$ and Payback period of less than 3 months. These benefits are quite

conservative since the software was only used for a period of 3 months to achieve the benefits identified.

5.8.7 Design Modifications

Design changes are made after a methodical study of the stress analysis and safety factor limit of each component. Von-Mises Stress distribution were taken into consideration and the following factors are monitored to get the optimum level of machine performance by maintain the strength and reliability.

1. Frame size and arc radius of the cut-out
2. Cylinder Size (outside and inside diameter) and weight
3. Bottom Inner Radius
4. Bottom face (Prefill Valve Fittings)
5. Pad holder thickness and corner radius

The following are the changes made to the design after stress analysed or outcome of stress analysis results

1. Frame size reduced from 9m x 5.5 m to 8m to 4m
2. Frame thickness reduced from 100mm to 90mm
3. Bigger radius on the corners to reduce stress levels
4. Tie rod hole size and placement
5. Cast Weight Reduced from 40 ton to 34 ton
6. Increased the radius at the inside base and made easy for machining
7. Thicken the bottom section and made as a flat face instead of ribs.

5.9 MWP Awards

The Metal Working Production (MWP) Awards were devised 25 years ago as a way of recognizing outstanding achievements in manufacturing technology. The awards

ceremony is the major event in the Manufacturing (MACH) exhibition every year and results for the winners in 10 different categories are announced in that event. Rhodes 10,600 ton Rubber Die Press was selected and awarded as a “Best Metal Forming/Fabrication Equipment” for the year 2008. The machine was also short-listed for Grand Prix Award, the award for the complete machine tool sector. This award adds prestige to the rubber die press family and to the company’s progress towards implementing innovative technologies.

6.0 Conclusion

Implementation of CAE applications helped the business to achieve its maximum benefits and improved the standards of the machine. For example, a small mistake in design and analysis of the hydraulic cylinder would lead to a biggest disaster of the project. Therefore the benefits achieved through 3D Modeling, Finite element analysis, 3D Animation are important to finish the project on time and help towards the success of the project

Also, designer’s confidence level increased in large scale and 20% of design time saving achieved in transforming preliminary designs to detail design. Also as described in Table 4, Table 5 and section 5.7.6, after the implementation of Finite Element Analysis, it makes a remarkable saving of 4.8% of a typical £1 million contract value with 548.64% rate of return and payback period of less than 3 months. 3D animation adds to the outline in sales, marketing and customer review meeting during the project duration.

After looking at the outcome, company’s confidence in CAE increased to a greater extent which leads to a complete change of the traditional level of design practice to next generation presses. In overall, the below Table 23, shows the benefits, by implementing CAE techniques in a typical bespoke engineering business will improve the company's reputation and achieve the maximum benefits with minimum lead time and resources.

Table 23: Benefits of CAE Application - Rubber Die Press

CAE Application	Tasks/ Activities	Milestone Achieved	Benefits
3D CAD Modelling	Fixing Size Constraints for press components	<ul style="list-style-type: none"> • Excess of 10000 Ton achieved by One Hydraulic Cylinder arrangement • Two moving table Design developed – Working on both sides of the press. (Fig. 20 & 21) • Complete 3D modelling of the machine 	<ul style="list-style-type: none"> • Compact Design for easy service & maintenance • Increased Production rate • Available of 3D Images for marketing and sales purposes
Finite Element Analysis	Analyse Press structure and all the main components	<ul style="list-style-type: none"> • Formulated the Sizing of a Hydraulic Cylinder for a press capable of excessive of 10,000 tonne with 700 bar working pressure • Formulated / Documented procedure for sizing the thickness of Frame Plates, Pad Holder Thickness, Moving Table. 	<ul style="list-style-type: none"> • Less Stress areas and minimum deflection gives improved life of the machine. • Made Saving of £48,000 of contract value £1 million in 2008 in terms of time and material • Documented all the Results for future press design.
3D Animation	Video Rendering	<ul style="list-style-type: none"> • 3D Model converted into animation as working video model 	<ul style="list-style-type: none"> • Regularly used in company marketing and sales presentation in UK and Abroad. • Played a vital role in winning a similar 10600 ton press for HAL, India worth of £2.5 million in June 2012.

CHAPTER 6 –DESIGN OF KNUCKLE JOINT PRESS AND MINTING PRESS

5.9 Introduction

Since 1970's Knuckle Joint Press and Minting Press are the most prestigious machines of Joseph Rhodes Limited, Wakefield. Joseph Rhodes has sold in excess of 700 of these machines to 40 industries and 34 mints worldwide. In context, both presses are classified as cold forming and operated with the same linkage mechanism but are different in construction. Knuckle joint press is operated with an extrusion mechanism where as coining press is a precision stamping mechanism.

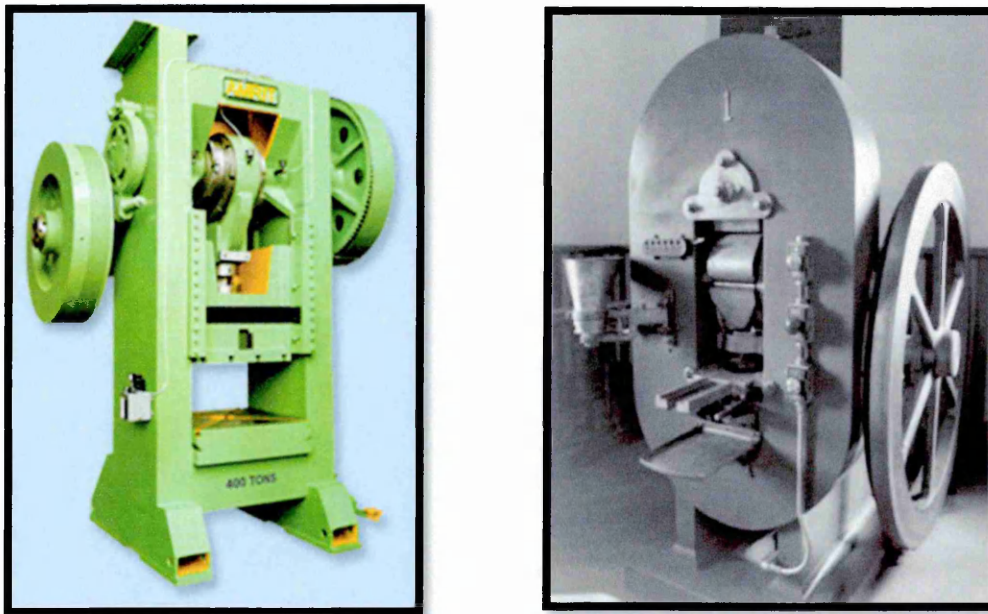

Figure 48: Typical Knuckle Joint Press

According to Tschaetsch, (2006) conventional presses (Figure 48) have long been equipped with a crank shaft or eccentric gear drive where slide velocity was symmetrical between the bottom and top halves of the press stroke. With this simple system press working was limited to those operations where the crank motion slide velocity would produce acceptable part. However the need for improved plastic flow of metal has led to

increased slide stroke. To meet the requirement for improved metal flow modern press builders have designed drive modifications that alter the slide motion and increase the dwell time.

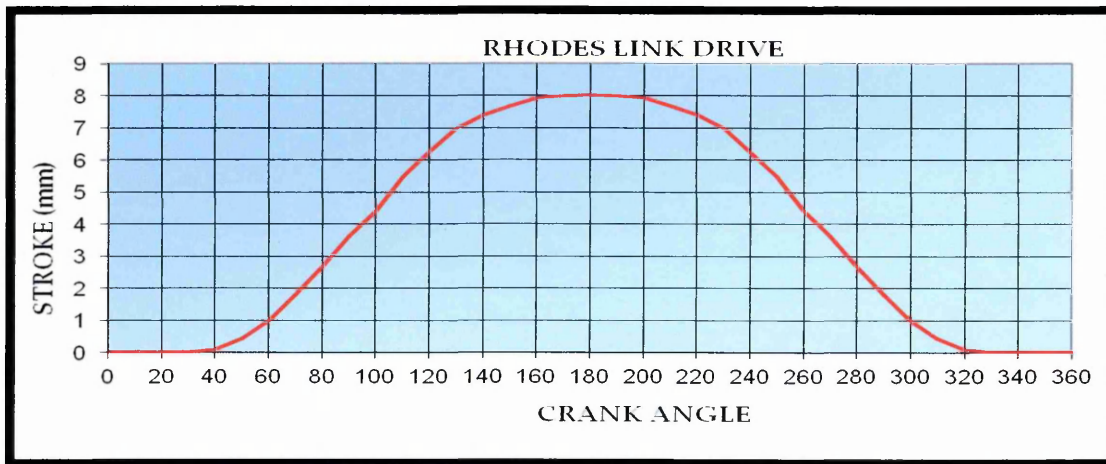

Figure 49: Time and Displacement Diagram

From **(Figure 49)** it is observed that the bottom of the press stroke provides a constant impact force for a considerable time period, which means a constant forming speed is achieved throughout the deformation of the part and helps in achieving a possible part quality and significantly longer tool service life.

Knuckle joint presses enable fast and flexible production of a wide range of parts. Joseph Rhodes is one of the world's leading manufacturers of impact extrusion press and has modified the mechanism which gives longer slide stroke. Although the knuckle joint motion is not a link motion, it is a modified slide motion and is used in presses where a high degree of metal flow is required to produce the finished part. Knuckle joint drives are primarily used in heavy coining or cold forging operation.

This particular chapter explains the development activities carried out in detail and enhanced manner. Since both presses are operating in a high speed technology, the main aim of this chapter is to explain the involvement of CAE application (dynamic simulation) in designing and analyzing the press components and the benefits achieved.

6.2 Knuckle Joint Press (or) Horizontal Impact Knuckle Joint Press

Tschaetsch, (2006) stated that as the name implies, the overall crank force required to make a component is transferred via a knuckle joint system. Joseph Rhodes knuckle joint presses are always a horizontal impact due to the height related and forming process limitations. The knuckle joint press (KJ Press) consists more than 1000's parts with 15 to 20 sub-assemblies in construction. The press ranges from KJ-8 to KJ-120 for aluminum which operates with a pressure capacity of 5 - 1000 tonne and 25 - 280 strokes per minute manufacturing non-ferrous (recyclable tubes and cans such as battery cases, toothpaste tubes, cosmetics, machine pharmaceutical tubes and aerosol cans (Figure 50). The press is also capable interconnecting a big production line of tubes and can by means of necessary electrical and mechanical features.



Figure 50: Knuckle Joint Press – Products

6.2.1 Press Description – KJ Press

The press frame is made of a one-piece steel fabrication, fully machined and stress relieved in order to make precise component production and press stability. Press linkage assembly (crank shaft, coupling, rear-link, front-link and moving slide), which is one of

the important sub-assemblies in the press, made of high strength alloy steel and cored to maximum for the purpose of weight reduction. The press is also dynamically balanced by adding a balanced weight for smooth and balanced running at high-speed production.

The press is driven by a main motor, which drives a dynamically balanced flywheel by a belt drive. A double helical main gear attached to the flywheel shaft rotates in a sealed oil container. A pneumatic friction clutch and brake unit mounted on the drive shaft controls the whole press. A fully automatic lubrication system passes through the core holes of the linkage system and deposited on the press base, which acts as a reservoir. The slug feeding system is mounted on the top of the press to make use of the gravity for the flow. Can takeoff assembly and a spring-loaded stripper are placed for the easy ejection of the finished product. The finished product is transferred through a conveyor assembly connected to the next process line as shown in the Figure 51, 52 and 53.

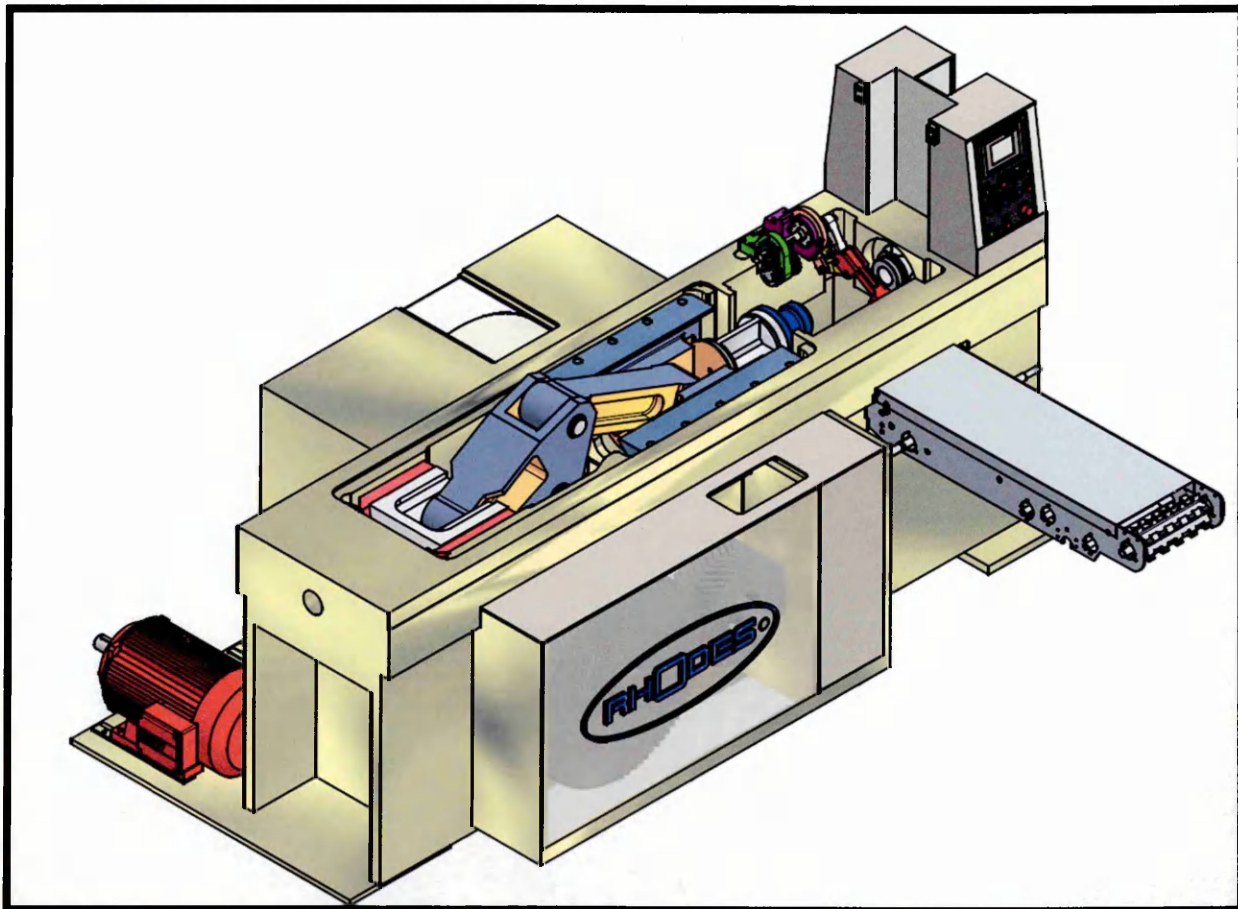

Figure 51: 3D CAD - Horizontal Knuckle Joint Press



Figure 52: View 1 - Typical Joseph Rhodes Knuckle Joint Press



Figure 53: View 2 - Typical Joseph Rhodes Knuckle Joint Press

6.2.3 Linkage Assembly

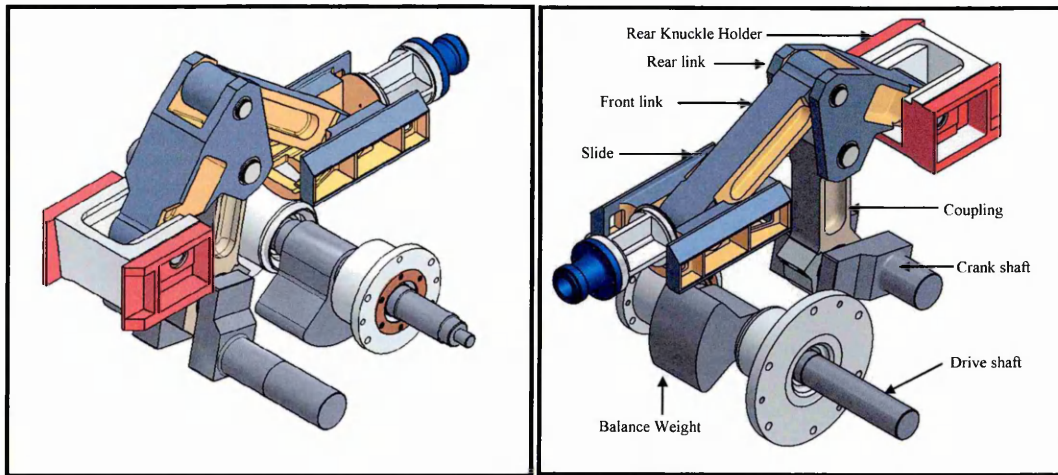

Figure 54: KJ Press - Linkage Assembly

As described in the press description, the linkage assembly is an important dynamic assembly in the press where it converts rotary motion into horizontal motion. As shown in Figure 54 and

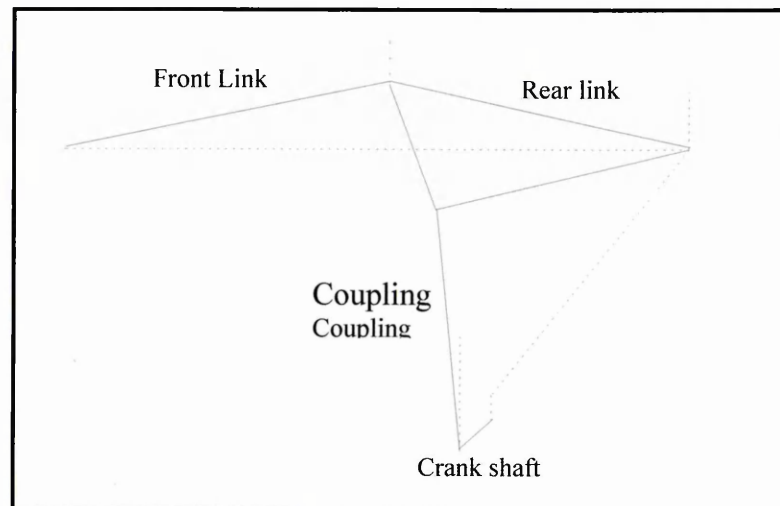

Figure 55: Knuckle Joint Press - Link configuration

55, the linkage assembly

contains punch head, slide, front link, rear link, rear knuckle holder, coupling, driving shaft and crankshaft. All the parts have to be carefully designed by using lighter material with greater strength and high reliability.

Major component like crankshaft and front knuckle link needs to be made from a forging of high tensile alloy steel. To avoid shock and vibration the crankshaft should be mounted in large plain phosphor bronze bearings and dynamically balanced during rotation. Rear knuckle link and couplings are made from high tensile alloy steel.

Moreover, the links needs to be perfectly configured as shown on the Figure 55 and aligned to suit the required stroke length and speed of the machine. Link configuration is a setting between the link lengths and extrusion length. The higher the extrusion length is the higher the link length and vice versa.

6.3 Her Majesty Elizabeth Minting (HME) Press

HME Minting is a Joseph Rhodes trademark founded in 1921 extensive range includes Open front, Four Pillar type and double sided mechanical presses.

The evolution of coin starts when the civilization starts trading and estimating the value of goods. Wickens, (1996) indicates, in those days coins were produced by hammering, casting and other processes. As the technology grows, minting processes make a significant role in making coins. Minting describes an industrial facility with machines which manufactures coins for currency and medals for sports events.

6.3.1 Press Description – HME Press

The Press consist of frame assembly, press slide, linkage assembly, blank feed system, clutch and brake unit, motorised wedge adjustment and ejector mechanism. The press is Designed and analyzed to provide minimum deflection and maximum stiffness whilst maintaining a high naturally frequency to eliminate harmonic oscillation build-up. The frame construction is of cast steel to achieve maximum damping benefits and is made of one piece fabrication, fully stress relieved prior to machining to avoid any distortion (Figure 56 and 57). The press slide is made of high strength aluminium alloy and guided in precision pre-loaded linear roller bearings. The crankshaft and drive shaft of the press is manufactured from a high tensile alloy steel forging to provide strength and toughness characteristics.



Figure 56: View 1: HME Minting Press: Joseph Rhodes Limited



Figure 57: View 2: HME Minting Press: Joseph Rhodes Limited

6.3.1.1 Blank Feed System

The blank feed mechanism comprises of a mechanical rotary feed bowl rigidly fixed to a base plate mounted on pre-loaded linear guide rails enabling the bowl and integral discharge chute to be retracted for accessibility (Figure 58). The discharge chute is adjustable to accommodate varying sizes of blanks and incorporates a blank sorting station to reject rogue blanks. The blanks are then transferred into a vertical feed tube where they stack as a single face to face column. A sensor monitors blank feed continuity in the vertical feed tube and should an interruption occur will de-energise the press drive. The blank at the bottom of the column is pushed into a feed finger on the dial plate which incrementally rotates the blank into the tooling for coining. A sensor monitors that a blank is in the feed fingers prior to feeding into the dies to prevent die-clash which can seriously damage the dies.

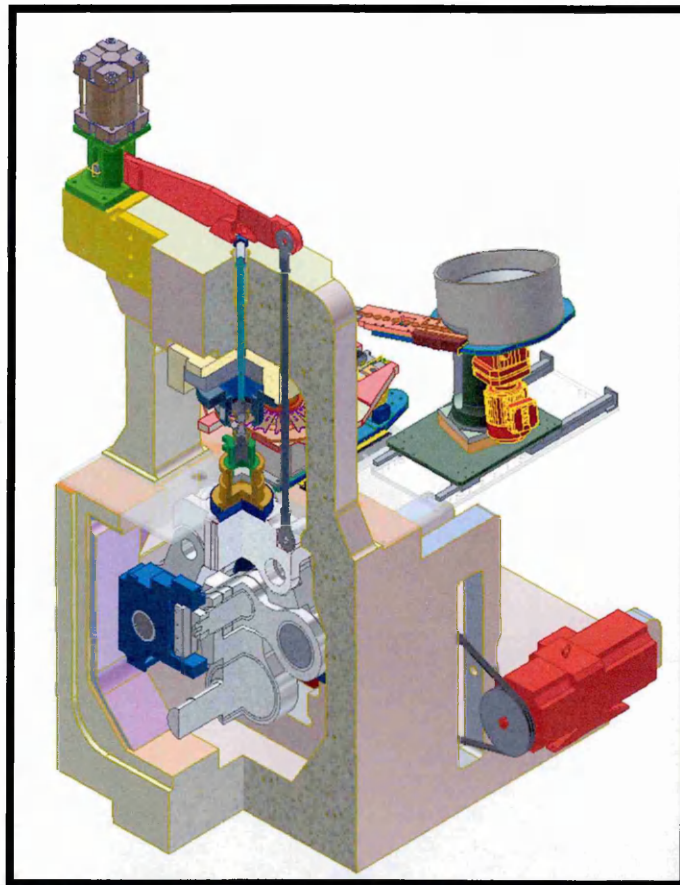

Figure 58: 3D CAD - HME Minting Press

6.3.1.2 Clutch and Brake Unit

The press is fitted with a pneumatic combined low inertia clutch and brake unit. Clutch response is optimised by the inclusion of a surge tank, protected by a relief valve, to ensure pressurised air is supplied to the unit at a high feed rate enabling rapid low slip response of clutch. The specially designed exhaust route through the crankshaft and sitting of the valve ensure the fastest possible brake response time. The system is controlled by a dual solenoid valve to achieve the maximum possible safety, with monitoring of both the pneumatic and electrical status.

6.3.1.3 Ejector Mechanism

The ejector system is a pneumatically locked lever mechanism with pivoting displacement connected directly to the slide. An easily accessible fine adjusting device is incorporated to accurately set the ejector.

6.4 Business Need

The company manufactures different types of KJ series press according to customer specification and industry standards. Basic design calculation for these presses are undertaken and recorded by the traditional manual method. But as the technology grows, the company was in the immense pressure to design the next stages of the presses with greater speeds, with less power consumption and properly balanced. Only by optimising the moving parts (reducing the material weight) to the maximum and by adding proper balance weight, the force generated horizontally can be converted into one acting vertically. This allows all the forces to be transmitted to the ground and hence the press is fixed firmly and balanced to achieve greater speed.

6.5 Dynamic Simulation (DS)

In a design environment, understanding the basic principle and motion of the system is a primary task. If the system is constructed with joints and a linkage mechanism, then the designer has to make a detail examination of properties kinematics, path generation and testing. In recent days computer aided programs generates the properties automatically with a minimum amount of input. Dynamic simulation is one of that program based tool used to analyse joints and links with time as a major function.

Younis, (2009) indicates, Autodesk Corporation having millions of customer worldwide for his products or software programmes incorporated dynamic simulation tool in his Inventor 2008 version as an upgrade. Since then, dynamic simulation is seen as a valuable tool to the design engineer working on moving assemblies with links and joints

6.5.1 Dynamic Simulation Capability

The capability of dynamic simulation is fully based on the model and the computer hardware configurations. The following are the main strengths of the Dynamic Simulation:

1. **Simulation of dynamic** motion in complex assemblies.
2. Able to calculate the amount of force, velocity and acceleration generated by the moving bodies (joints and links) due to effect of natural force such as gravity and friction on the mechanism
3. Output graphs can be exported to Microsoft word or excel for further analysis and discussion.
4. Able to transfer the reaction force to stress analysis environment to see how parts reacts to the dynamic load.
5. Eliminates physical prototype from the design process completely as discussed in chapter 2.

-
6. Simulates 3D CAD mechanism and can be saved as animation format for sales and marketing purpose.

6.5.2 Application of Dynamic Simulation

In order to make a perfect balance, the press needs to be designed accurately with appropriate weight measurement for the components. After careful consideration of the Rhodes KJ press, the arrangement remains the same for the full series of KJ presses but the link configuration changes on customer specified extruded length. The main purpose of this exercise is to find out the forces on Y direction and converting the excessive values into the X direction by adding appropriate balance weights. The initial task/activity was to 3D Model the linkage assembly with the crankshaft and add dynamic simulation mode to make sure all joints are properly constrained and connected to each other by proper means. Once the joints are made as per the machine specification, the input velocity or acceleration are applied to the crankshaft. This gives motion to the moving parts and generates all the possible forces in x, y and z direction in forms of data and graphs. The data can be exported to Microsoft Excel for further analysis of forces generated. As explained, in the capability section, Dynamic Simulation not only calculates the inertial forces generated for balancing the machine, it will also transfer the results (calculated forces) to FEA mode for analysis. The below Figure 59, illustrates the work flow of the Dynamic Simulation process and the interaction with the FEA.

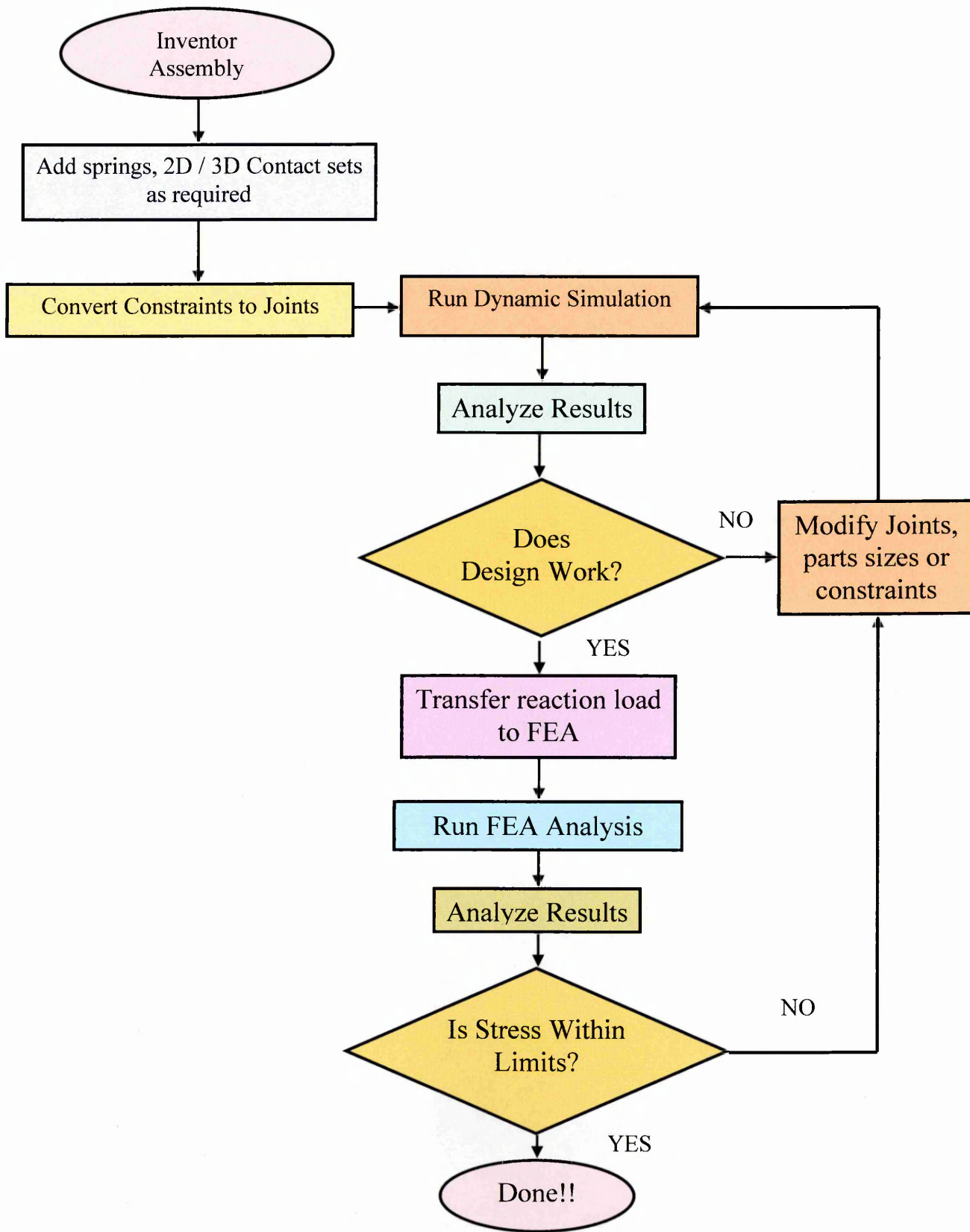

Figure 59: Typical Dynamic Simulation Workflow: Joseph Rhodes Limited

6.5.3 Sample Calculation – Knuckle Joint Press

Howarth and Langford, (2004) described in their technical part, in order to prove that the Computer Aided Simulation is faster, more accurate, reliable and provides the same results as theoretical calculation, the analyst must provide accurate inputs in to the software. To provide such an input, the designers have to understand the machine performance and its operating conditions.

Joseph Rhodes developed the Knuckle Joint Press for more than three decades for its effective functioning and its speed. The theoretical calculation performed by Rhodes Engineers in 1980's were proved and executed in several machines manufactured and supplied across the world. To prove Dynamic Simulation as a tool to calculate all the outer balance force, an example of KJ machine were taken for testing.

The below Figure 60,61,62 and 63 compares the proved theoretical calculations and dynamic simulation calculation which simulates the force generated horizontally and vertically (towards the ground) by the linkage assembly, driving shaft and crankshaft without and with adding a balance weight.

The balance weight is the critical part of the calculation which transfers all the horizontal forces in to vertical forces. The shape and the size of the balance weight are determined by horizontal out of balance force. The two sets of graphs Figure 60, 61, 62 and 63 showed the co-relation and matches very closely, although there are little discrepancies between the theoretical and simulation results.

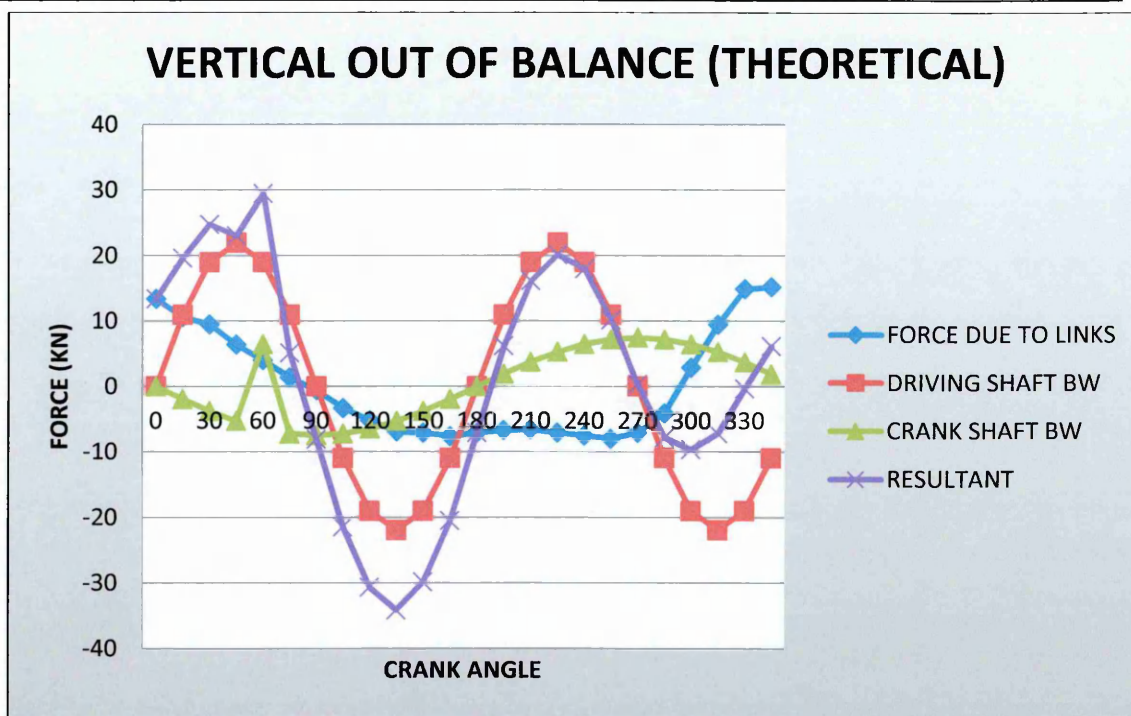

Figure 60: KJ Balancing - Vertical Out of Balance (Theoretical)

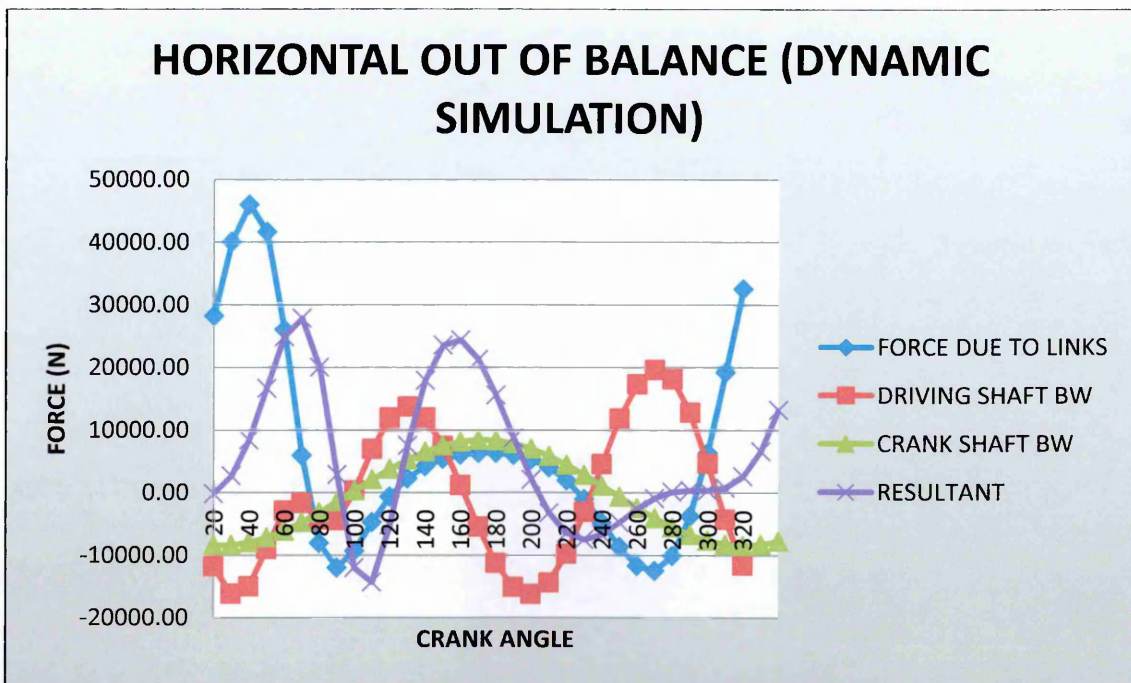

Figure 61: KJ Balancing - Vertical Out of Balance (Dynamic Simulation)

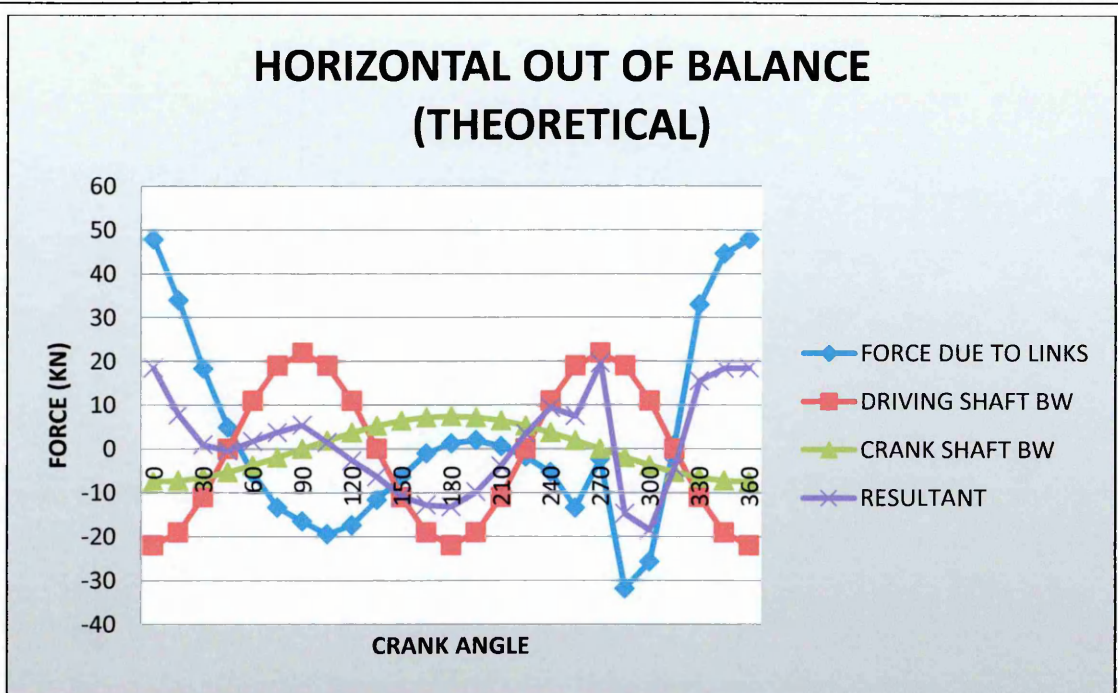

Figure 62: Horizontal Out of Balance (Theoretical)

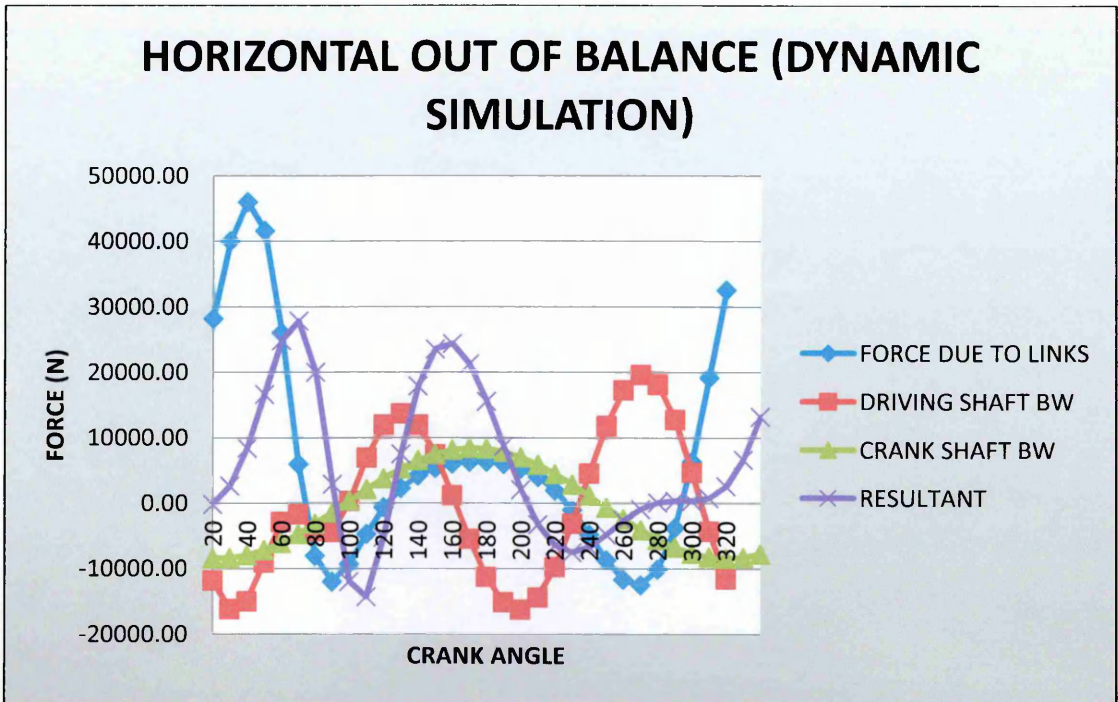

Figure 63: KJ Balancing - Horizontal Out of Balance (Dynamic Simulation)

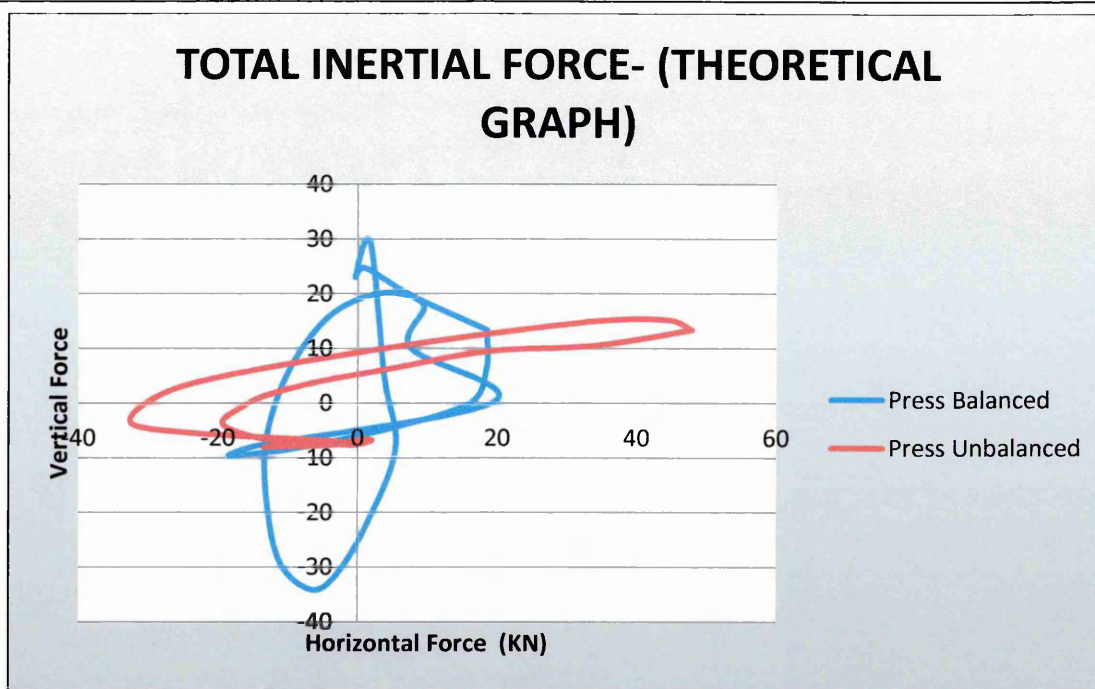

Figure 64: KJ Balancing - Total Inertial Force (Theoretical)

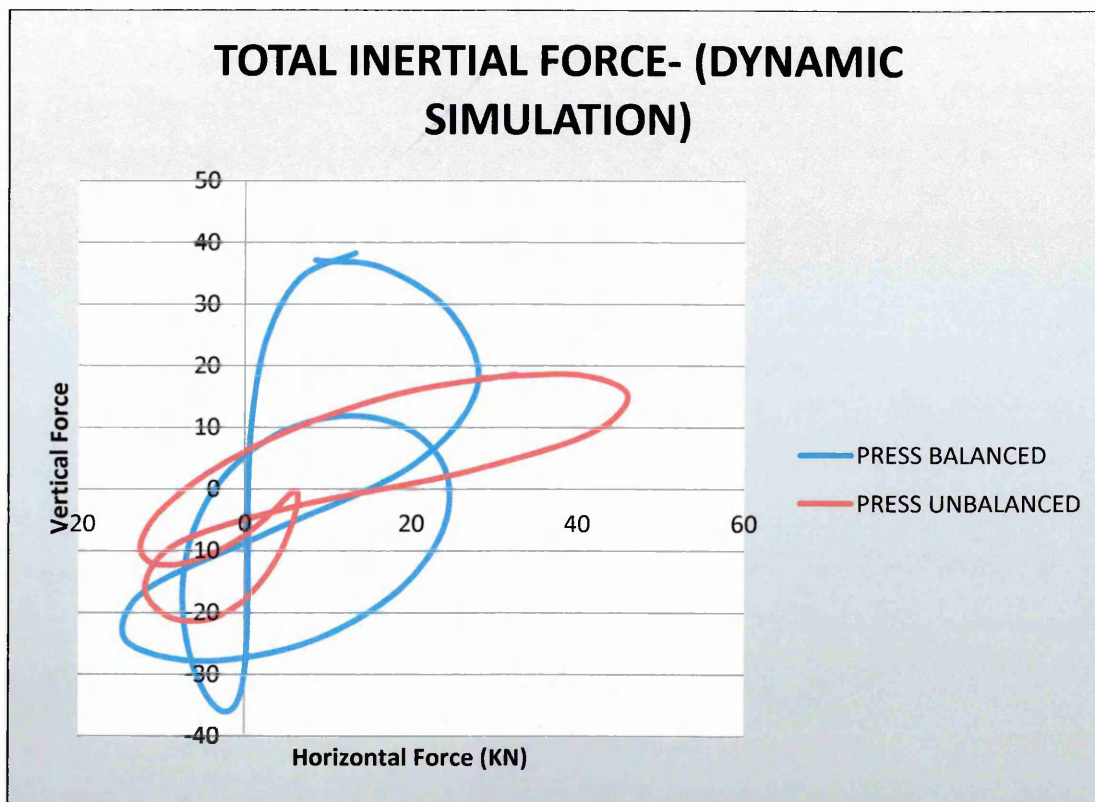

Figure 65: KJ Balancing - Total Inertial Force (Dynamic Simulation)

The above Figure 64 and 65, compares manual and simulation all the force generated in horizontal axis are converted into vertical axis by adding appropriate balance weights of X kg to the linkage in order to stop moving the press when its working under full capacity. The results (Table 24) are 12.31% - 20.36% of what give actual values of forces in total variation in the values between the manual and dynamic simulation and 98% accurate in balance weight analysis.

Table 24: Result Comparison

DYNAMIC SIMULATION OF KJ-35 Horizontal (X) (KN)			THEORETICAL OF KJ 35S Horizontal (X) (KN)		
Description	Minimum	Maximum	Description	Minimum	Maximum
Force Due to Links	-12.003	45.992	Force Due to Links	-31.8	47.9
Driving Shaft BW	-16.242	19.644	Driving Shaft BW	-21.94	21.94
Crank Shaft BW	-8.448	8.435	Crank Shaft BW	-7.47	7.47
Resultant Force	-14.313	27.838	Resultant Force	-18.47	18.49

DYNAMIC SIMULATION OF KJ - 35 Vertical (X) (KN)			THEORETICAL OF KJ -35S Vertical (X)		
Description	Minimum	Maximum	Description	Minimum	Maximum
Force Due to Links	-21.22	18.629	Force Due to Links	-13.4	13.4
Driving Shaft BW	-16.971	16.92	Driving Shaft BW	-21.94	21.94
Crank Shaft BW	-8.447	8.425	Crank Shaft BW	-7.47	7.47
Resultant Force	-36.019	38.297	Resultant Force	-34.12	25.06

The difference between KJ-35 and KJ-35S is ratings from the Bottom Dead Centre (B.D.C) which is the distance through which the maximum pressure capacity can be applied. The theoretical values shown on the table 24, were achieved after repeat manual calculations and then it was validated against the actual performance of the machine. The time and cost spent to accomplish the procedure was very expensive and the sample explained in the Table 25.

Due to the technological change, by running the dynamic simulation of the machine, it is clearly visible that, vertical forces are much more concentrated on +ve acceleration side, which imply that the link configuration needs to be adjusted in conjunction changes to the balance weight reduction of original 15 Kg to 12.3K. The repeat analysis needs to be carried out until the reach of proper configuration and appropriate balance weight.

Therefore, the impact of the technological change influenced the Engineering Industry by saving time and cost.

6.5.4 Benefits of Dynamic Simulation

As described in the previous sections, dynamic simulation is very clever and easy to use. The benefits in terms of time and material savings achieved with the help of the software program were spectacular. The software reduced the designer's time by 90% and increased their confidence in designing the press. Table 25 & 26, explains material saving and overall frame work for a typical calculation work for the KJ or HME Press.

Table 25: Material Savings - Designing KJ Press

Description	Theoretical Calculation	Dynamic Sim.	Savings	Cost
	Tonne	Tonne	Tonnes	£ (900/t)
Design of Links	22	18	4	3600.00
Balance Weight	0.3	0.15	0.15	135.00
Frame	6.5	5	1.5	1350.00
Total Hours	28.8	23.15	5.65	5085.00

Table 26: Time Plan and Saving - Designing KJ Press

Description	Theoretical Calculation	Dynamic Simulation	Savings	Cost
	Hour	Hour	Hour	£ (25/hr)
Link configuration	22.5	15	7.5	187.5
Design of Links	157.5	37.5	120	3000.00
Force Calculation	75	5	70	1750.00
Balance Weight Configuration	30	7.5	22.5	562.50
Review Links design	22.5	2	20.5	512.50
Review Calculation	22.5	2	20.5	512.50
Review Balance Weight Configuration	15	2	13	325.00
Total Hours	345	71	274	6850.00

6.6 Sample Stress Calculation – HME Minting Press

6.6.1 Background

The slide and its assembly (Figure 66) are the critical part of the minting press which determines the performance and efficiency of the machine. The slide connected by the links energised by the crankshaft rotation, holds the bottom die of the tool and operates 850 strokes per minute with a stroke length of 8.5 mm. In order to stroke 8.5 mm at 850 times per minutes, the slide has to be lighter and stronger. To achieve the light weight by maintaining the strength, repeated stress analysis were carried out for different high grade material for optimization.

After numerous iteration, the moving slide was made of high strength aluminium alloy and treated as a important component in the linkage assembly. There were more concerns raised in improving the design of the slide in terms of stress areas due to shock loads and deflection due to material. After repeated stress analysis of the slide, the

major stress and deflection area are identified and rectified. The following sections covers all the physical properties (Table 27), Settings (Table 28 & 29), material (Table 30), operating conditions (Table 31) of the slide finite element analysis and the results of the analysis. are explained in Table 32 and Table 33.

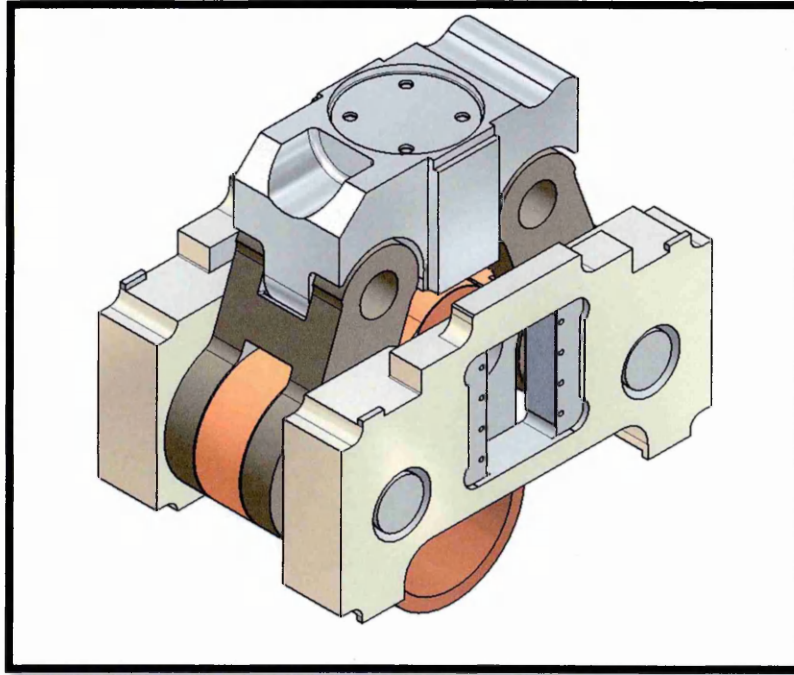

Figure 66: Linkage Assembly - HME Minting Press

6.6.2 Physical Properties

Table 27: Physical Properties

Material	ALUMEC 89
Density	2.82 g/cm ³
Mass	38.0813 kg
Area	558197 mm ²
Volume	13504000 mm ³
Center of Gravity	x=3.83001 mm y=2.61791 mm z=99.9934 mm

6.6.3 General Objective and Settings

Table 28: Analysis Settings

Design Objective	Single Point
Simulation Type	Static Analysis
Last Modification Date	16/07/2012, 10:41
Detect and Eliminate Rigid Body Modes	No

6.6.4 Advanced Settings

Table 29: Advanced Settings

Avg. Element Size (fraction of model diameter)	0.1
Min. Element Size (fraction of avg. size)	0.2
Grading Factor	1.5
Max. Turn Angle	60 deg
Create Curved Mesh Elements	Yes

6.6.5 Material(s)

Table 30: Material Properties

Name	ALUMEC 89	
General	Mass Density	2.82 g/cm ³
	Yield Strength	542 MPa
	Ultimate Tensile Strength	589 MPa
Stress	Young's Modulus	71.5 GPa
	Poisson's Ratio	0.38 ul
	Shear Modulus	25.9058 GPa
Stress Thermal	Expansion Coefficient	0.0000857 ul/c
	Thermal Conductivity	169 W/(m K)
	Specific Heat	1500 J/(kg c)
Part Name(s)	1R158252-MODS TO SLIDE-REV1	

6.6.6 Operating conditions

Table 31: Boundary Conditions

Load Type	Force
Magnitude	1569064.000 N
Vector X	0.000 N
Vector Y	-1569064.000 N
Vector Z	0.000 N
Load Type	Force
Magnitude	29419.950 N
Vector X	0.000 N
Vector Y	-29419.950 N
Vector Z	0.000 N

Selected Face(s)

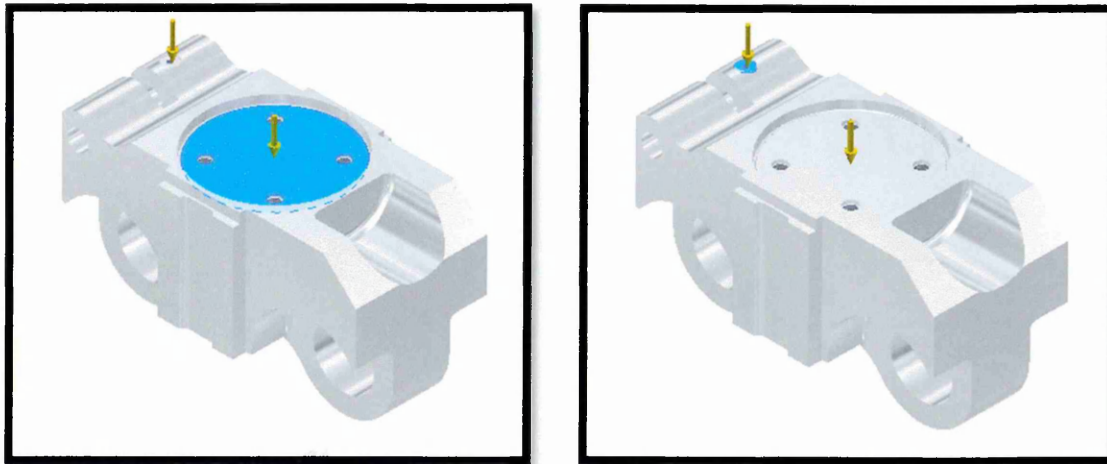

Figure 67: Load Faces

Table 32: Reaction Force and Moment on Constraints

Constraint Name	Reaction Force		Reaction Moment	
	Magnitude	Component (X,Y,Z)	Magnitude	Component (X,Y,Z)
Fixed Constraint 1	1598480 N	0 N	5998.97 N m	-1176.47 N m
		1598480 N		0 N m
		0 N		5882.48 N m

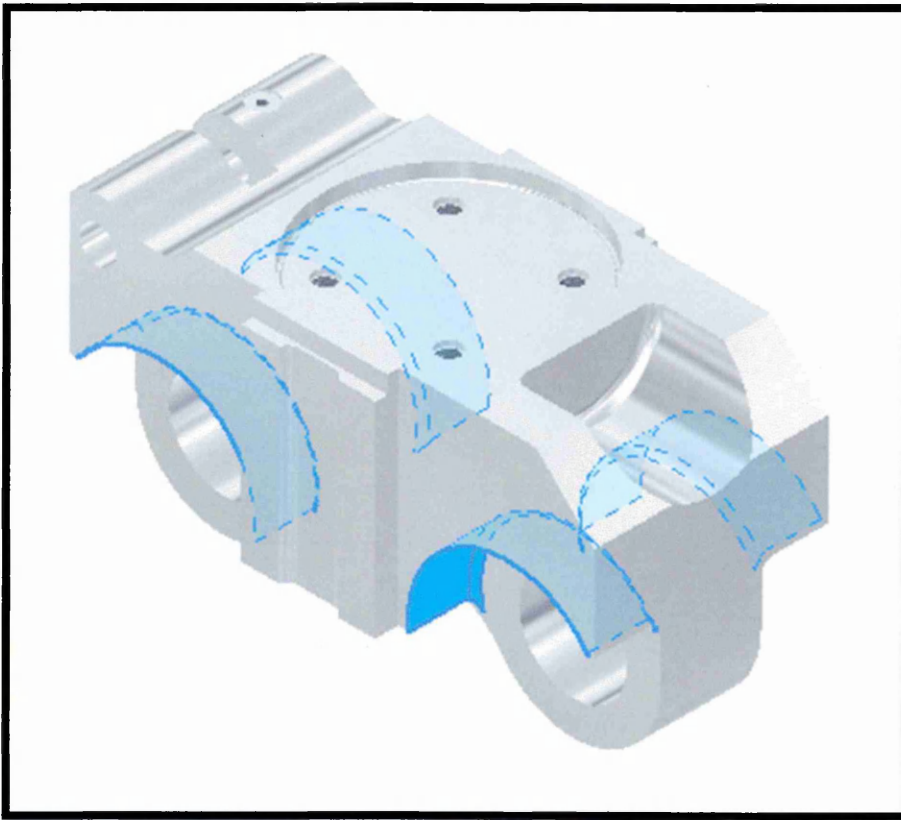

Figure 68: Constraints

6.6.7 Results

The results of the analysis are detailed in the below and the Figure 69 to Figure 73 shows stress and strain concentrations.

Table 33: Result Summary

Name	Minimum	Maximum
Volume	13504200 mm ³	
Mass	38.0817 kg	
Von Mises Stress	0.130894 MPa	162.889 MPa
1st Principal Stress	-57.3558 MPa	113.636 MPa
3rd Principal Stress	-169.263 MPa	22.3275 MPa
Displacement	0 mm	0.092555 mm
Safety Factor	3.32742 ul	15 ul

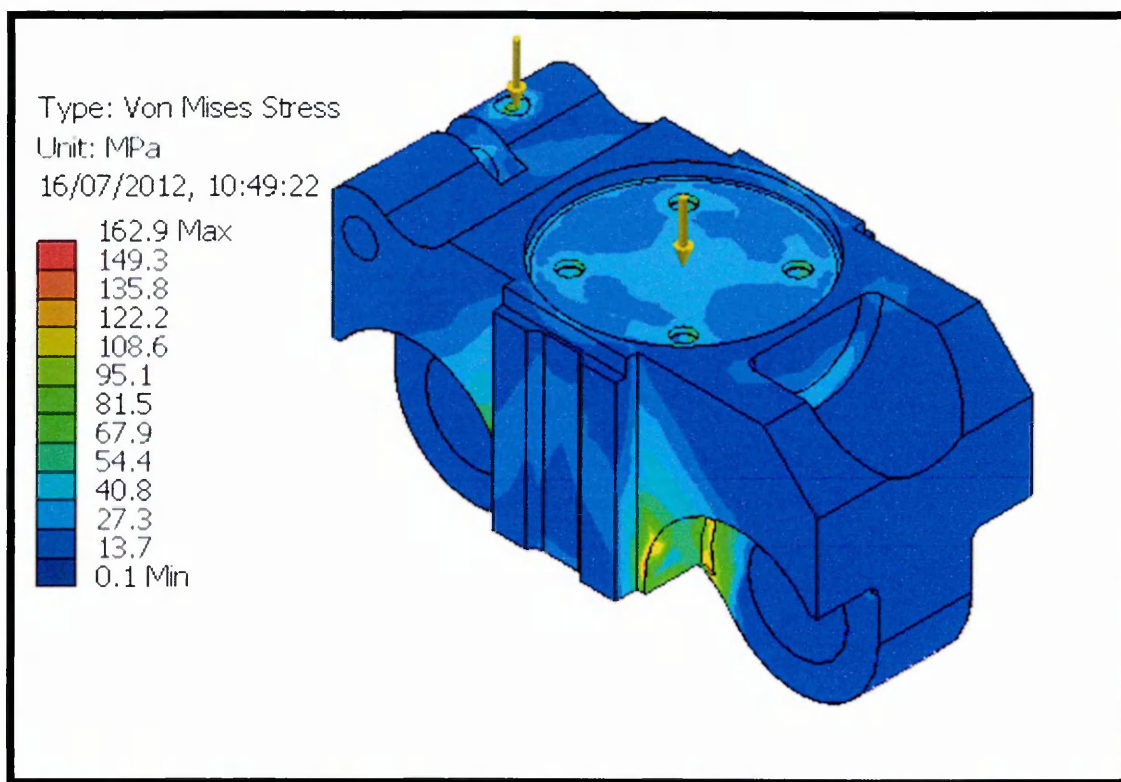

Figure 69: Von-Mises Stress

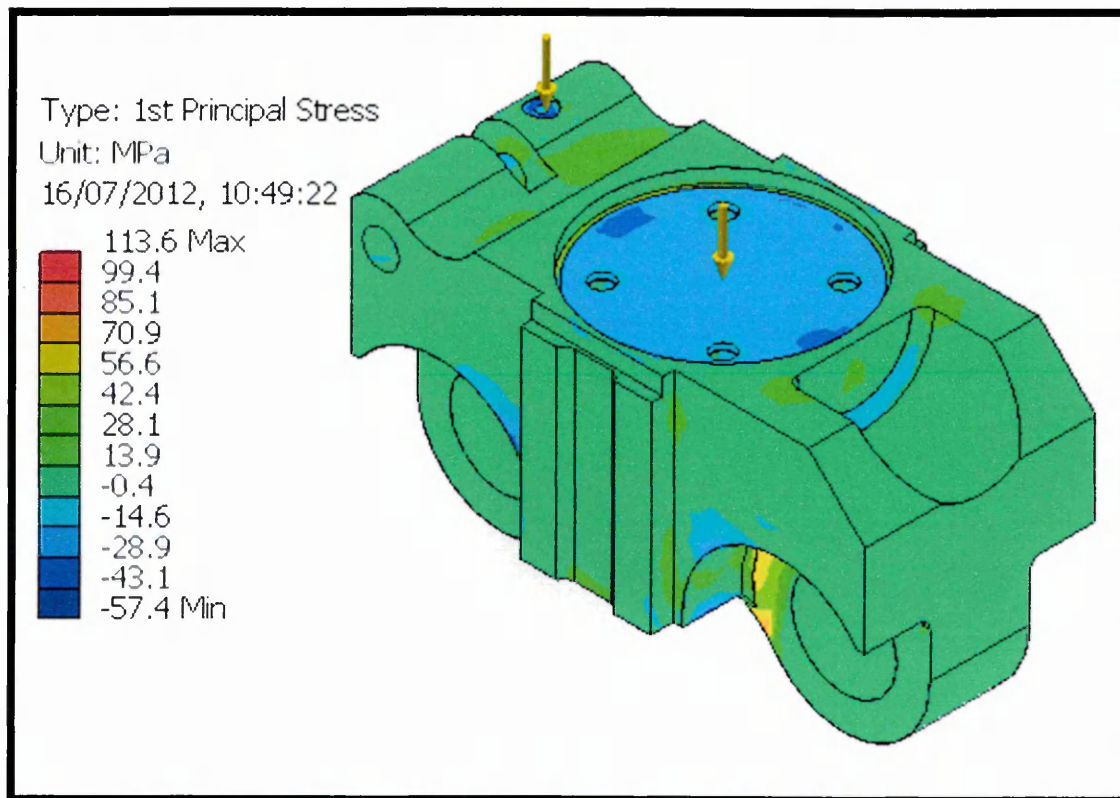

Figure 70: 1st Principal Stress

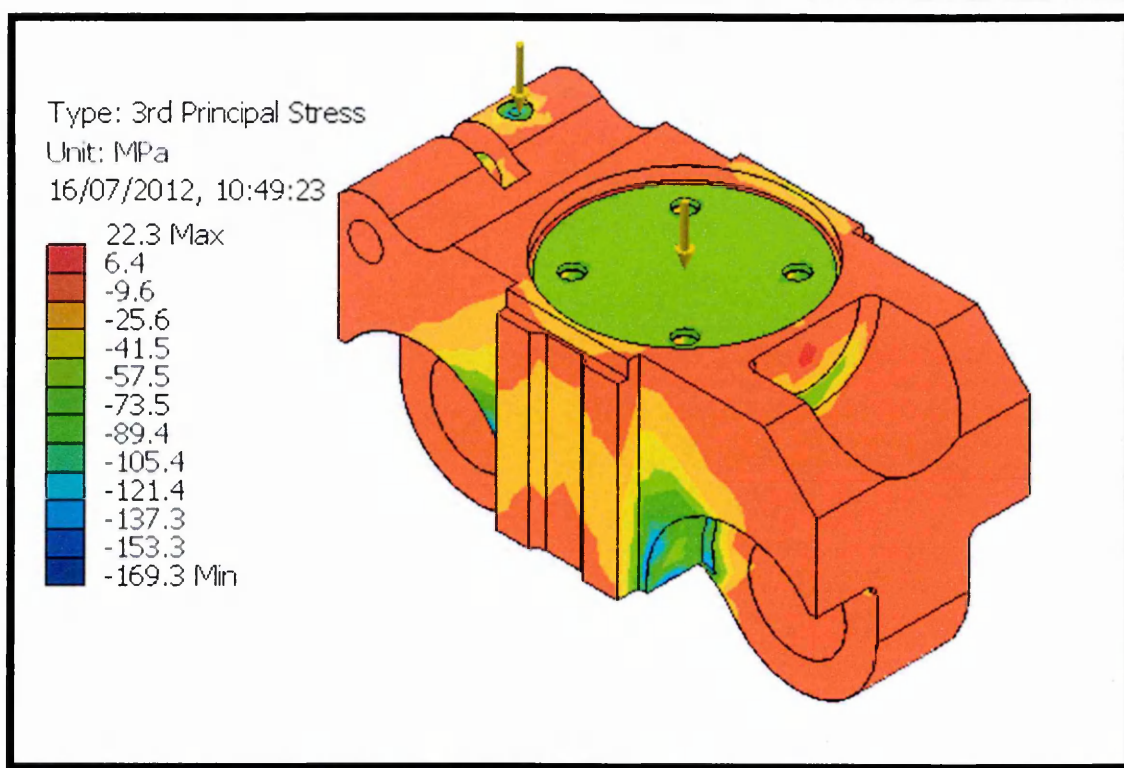

Figure 71: 3rd Principal Stress

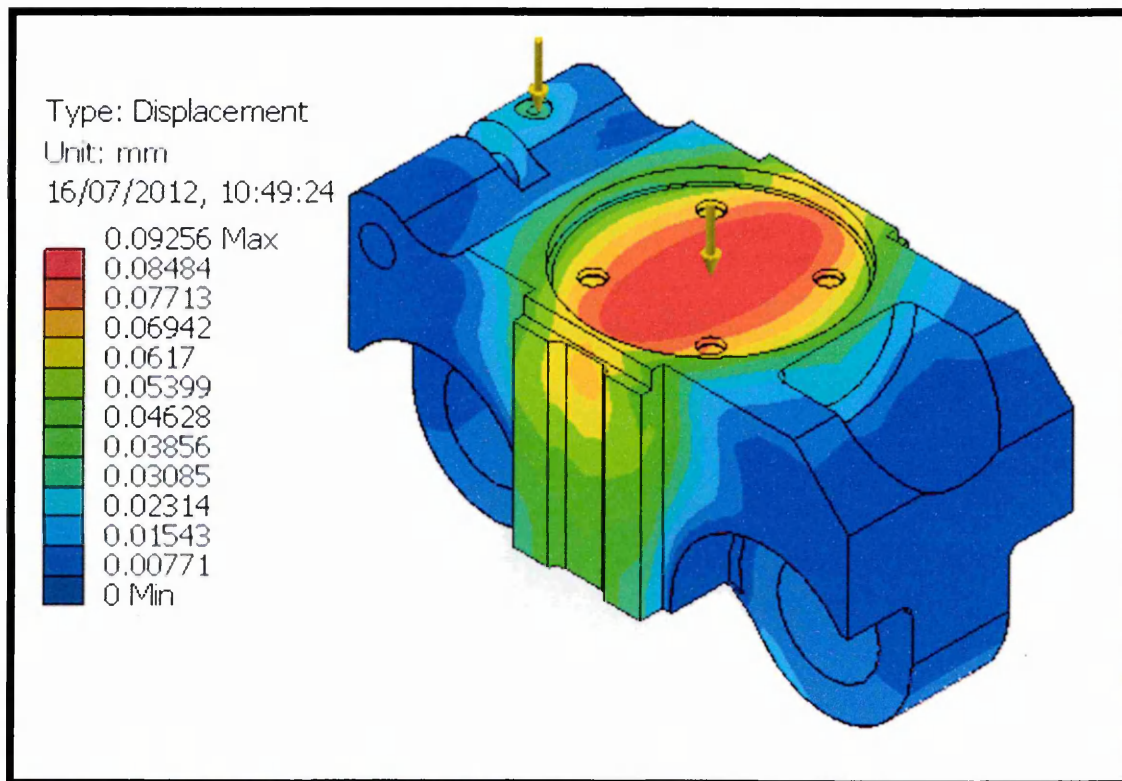

Figure 72: Displacement

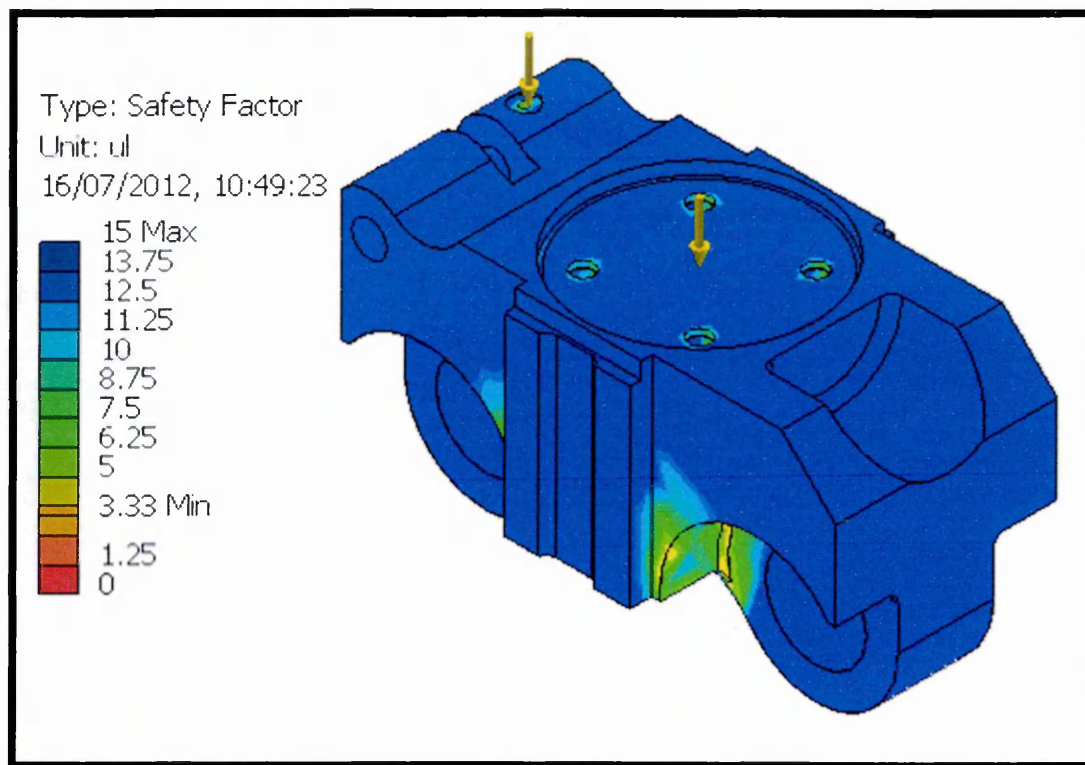

Figure 73: Safety Factor

6.7 Benefits Achieved (Time and Cost)

The benefits achieved by implementing Dynamic Simulation into the development of two press machine Knuckle Joint and HME Minting in Joseph Rhodes was enormous in terms of time saving. The system implemented helps the new design engineers to understand about the machine parameters affecting the performance and how the parameters are taken into account in the design stage to improve the performance.

In both presses, balancing entails more concentration and needs more development because of the machine stability. Since the machine works at very high speed, the load generated has to be compensated to achieve a good product definition. After implemented Dynamic Simulation, the computer generated program analysed the link configuration with all the inertial forces affecting the machine stability. The designer can then easily accommodate the balance weight to counter balance the inertia forces generated. Two major benefits are achieved as follows:

1. Reduce significant designer's time in performing theoretical calculation and developing formulas. As explained in table 25 and 26, dynamic simulation saves £6,850 (80%) of the designer's time before finalising design parameter with 5.65 tonnes (20%) with a cost of £5085 savings in the material cost.
2. Excessive material in the frame, linkage assembly and balance weights were reduced by 20%. This increased the speed of the machine and able to maintain high stability.

Output generated from Dynamic Simulation software was exported to Microsoft excel for future analysis and used for sales and marketing purposes.

Sample database for the KJ series were developed for a forthcoming order. This reduces the preparation time before and after design.

6.8 Conclusion

Dynamic simulation concept was greatly involved and played a vital role in the development of next generation Knuckle Joint press. The results carried out in this case study was tested, verified to the proven theoretical calculation and confirmed in one of the press machine manufactured at Joseph Rhodes. Therefore, the advanced simulation techniques such as dynamic simulation available in the market saves designers time and effort in calculating inertial forces and gives more confidence to design. Table 34, explains the complete of picture of dynamic simulation and its benefits with respect to Knuckle joint press and HME minting press. In overall with an investment of £1350.00 (Dynamic Simulation Software cost in 2008), the benefits achieved are worth £11,170.00 resulting in 9.35% saving for a £250,000 machine including 1631.48% rate of return and less than 1 month payback period.

Table 34: Benefits of CAE Application - Knuckle Joint Press and HME Minting Press

CAE Application	Tasks/ Activities	Milestone Achieved	Benefits
Dynamic Simulation	Analysis Joints and find Reaction Forces	Developed a program for Link Configuration.	Able to analyse different link configuration for different speed
		Structured a methodical procedure to calculate balance weight.	Machine stability increased with more horizontal force transmitted to vertical force
		Better link configuration and proper balance weight by minimal amount of work.	Increased the speed of the machine from 180 SPM to 220 SPM
		Inertial force calculation programmed using Dynamic simulation.	Three Weeks of theoretical calculation are converted into three hour computer simulated process (90% of designer's time)
		Design time savings.	Overall Savings 274 Hr. (274*25=£6850.00) –2008 Rate
Finite Element Analysis	Analyze Press structure	One Piece fabricated press structure.	Rigid Frame with minimum material
		Reduced thickness of the front link, rear link and knuckle holder.	Less Stress Concentrated areas and maintain minimum deflection
		HME press –achieved high strength by reducing slide weight with repeat stress analysis.	HME Press – Number of strokes increased from 1000 to 1200/minute
		KJ Press – Remarkable Material Savings.	Overall Savings 5.65 Tonne (5.95*900 = £5085.00) – Based in 2008
3D Animation	Video Rendering	3D Model converted into animation as working video model of KJ press and HME minting press.	Used in company marketing and sales presentation in UK and abroad
			Played a vital part to win order for 3 Knuckle Joint Press worth £750K between 2008 - 2010

CHAPTER 7 – DESIGN OF CENTEX EXTRUDER

7.1 Introduction

Centex Extruder is a brick, hollow block and field drainage pipe manufacturing machine which falls under one of the clay working machineries developed by Craven Fawcett Limited (a subsidiary company of Joseph Rhodes Limited) in early 1920's to supply worldwide building industry. Since then the Centex has gone through major research and development activities with respect to benefits like quality, output, power consumption etc. Now the Centex extruder has wide range of starting output as little as 3000 bricks/hour to maximum of 20,000 bricks/hour depends on the customer requirements. This chapter is completely focussed on research and development activity carried on Centex extruder and explains how latest 3D CAD modelling techniques and how computational fluid dynamics helped to achieve maximum required benefits.

7.2 Extruder

Extrusion is a process originally used for making ceramics. This process as a basic principle, the concept is then widely used in many industries like plastics, chemical, pharmaceuticals, rubber and even food. Frank Handle (2007) the editor of Extrusion in Ceramics states the concept of shaping a product by forming a continuous cross-section was developed at least in beginning of the 17th century. He also mentioned the different type of extrusion used for different modes of operation satisfies the market needs and customer expectations. Out of all these types, auger extruder is the most common type used in the ceramics industry.

An auger is basically a drilling device which normally includes a helical screw blade. The main purpose of the blade in the auger is to force the material to move out in a steady extrusion. All the Craven Fawcett Centex, Centaur, Centem are constructed with

the auger type screw mechanism before the mouthpiece. Auger sections are cast in CF 28 chrome alloy for long life and high strength. The below Figure 74 was draw in 3D as a demonstration to exhibit the difference between an in-house drawing compared to a sub-contracted drawing. The conversions of 2D to 3D are compared between In-House work and Sub-contracting work in reference to time and cost and provided in the Table 35. Thus it was proven that in-house drawing is more efficient in terms of design accuracy, time and cost.

Table 35: Extruder - Sub-Contract cost Vs Actual Cost

Quotation for Subcontract	Actual – In-House
Number of Drawings = 425	Number of Drawings = 425
Number of Hours = 1036	Number of Hours = 225
Total Cost = £28,000	Total Cost = £5,625.00
Overall Savings = £22,375.00	

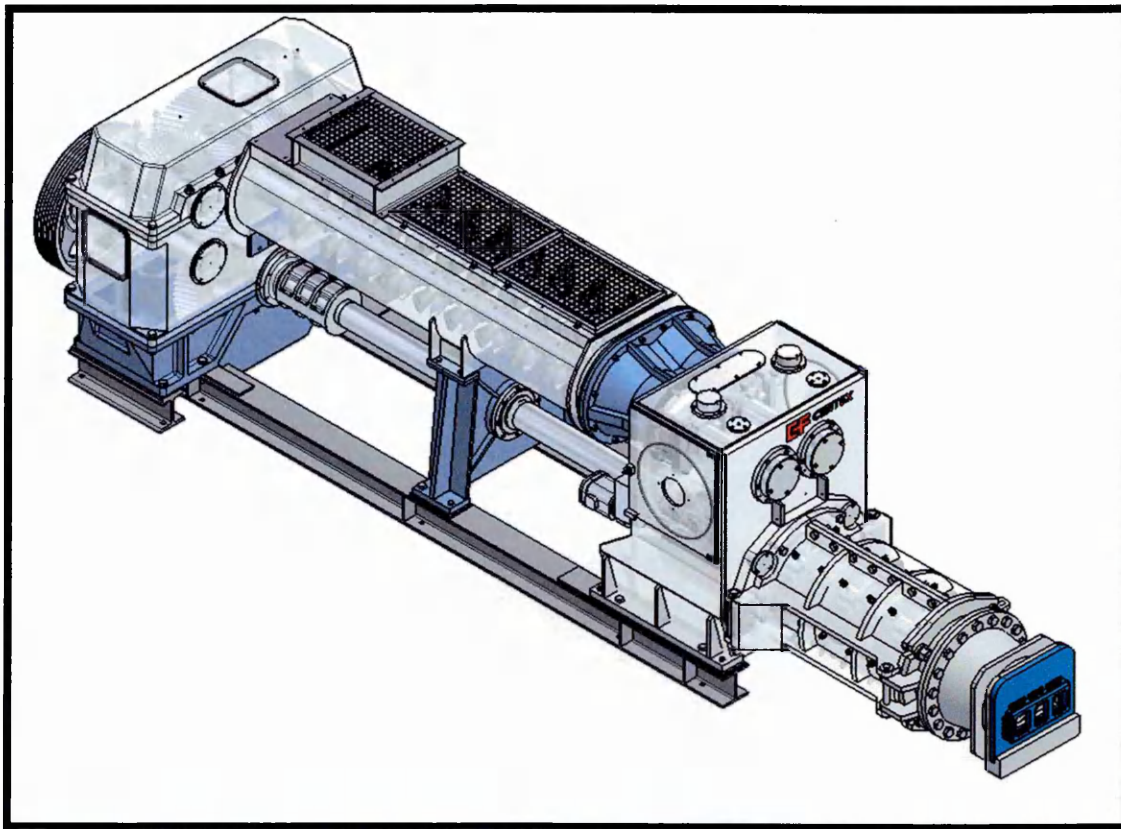

Figure 74: 3D CAD - Craven Fawcett - Centex Extruder

7.3 2D to 3D CAD Modelling

As discussed in chapter 4-section 4.4.1.3, 2D to 3D CAD modelling is still a necessary technology for engineering industries to show their product in a tender document to the market. Craven Fawcett Centex extruder has taken for the experiment, to show how 3D CAD modelling and its technology are helpful for customer demonstration and saves time and cost to the engineering business. Joseph Rhodes acquired a quotation of £29,000 to convert 2D detail drawing to 3D CAD model of one of the Craven Extruder Model and compared to the in-House work, in order to identify the benefits

In order to identify the actual conversion benefits from 2D design to 3D design the following factors were carefully monitored in the development work of Craven's extruder:

1. Design Software
2. Designer experience
3. Design Accuracy
4. Design Time and Cost

7.3.1 Design Software

The best option to choose competent software will always depend on the user interface and program logic. Akman, et al., (1989) describes CAD software as having an appropriate definitive notation for geometric modeling and graphic outlook that will stand out from the other competing software. In the current market, designing the extruder was examined with various tool bars and layouts with in the software which lead to produce a well-constructed design that appeared more attractive and life-like.

7.3.2 Designer Experience

Since late 1940's, researchers are constantly studying on human interaction between machine and design system that addresses the experience in user interface. The higher the interaction means the greater the experience vice versa. Craven's basic designs were generated in 1930's to 1960's and are still changeable to current designers to beat the calculation accuracy's in many parts of the extruder. Therefore the greater experience delivers further advantage to the project and to the finished product such as reducing time to

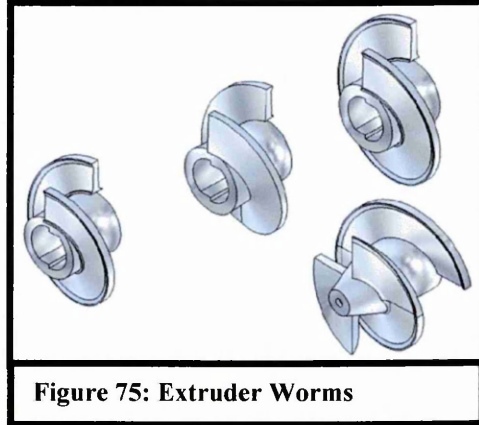

Figure 75: Extruder Worms

work i.e. cost saving, improving quality of work and delivering best outcomes. For example, Figure 75: Extruder worms are the most complicated part in the extruder, even a slight change in flight path or pitch will lead to a change in the efficiency of the machine.

7.3.3 Design Accuracy

Accuracy is the word indicates degree of measurement of quality to the original value of the product or component. Design accuracy measures the standard of the drawing with respect to the quality of work produced and allocated time. N.E Warner (1998) describes design validation is purely depends on two types of accuracy called absolute and drift accuracy. Absolute accuracy is the one include initial tolerances whereas the drift accuracy doesn't. By considering the absolute accuracy, the 3D designer can examine the errors with interference and collision checking between components. Most of the components in the Extruder need more accuracy. For example, the worms need to be in defined pitch and throw angle. A small change of degree in the throw angle will affect the outcome and results in loss of production.

Therefore the accuracy of design with techniques and software eliminates the error and improve the accuracy to form a good definition of the product.

7.3.3 Design Time and Cost

Time and cost are both interlinked with each other in the field of engineering. Design time decides the duration and cost of the project as it places a critical path in the project plan. In simple terms, as the time decrease the cost of the project increases and vice versa. In order to give a quality outcome, the design should be reliable and accountable. Complicated design results in time increase which in turn increase the cost. Therefore in engineering sectors, both time and cost should be identified initially to avoid unnecessary changes.

7.4 Development of Centex Extruder

The benefits achieved by 3D CAD modelling and Computer Aided animation of the Centex extruder inspired the Joseph Rhodes Board of directors to start another Knowledge Transfer Partnership project with Sheffield Hallam University. The main objective of that project is to analyse the extruder worms using Computation Fluid Dynamics system and study the heat transfer system in Rhodes Autoclave business. The project was successfully implemented with another KTP associate and finished in June 2012 with the entire milestone covered. The pictures below (Figure 76 and 77) are few examples from the project.

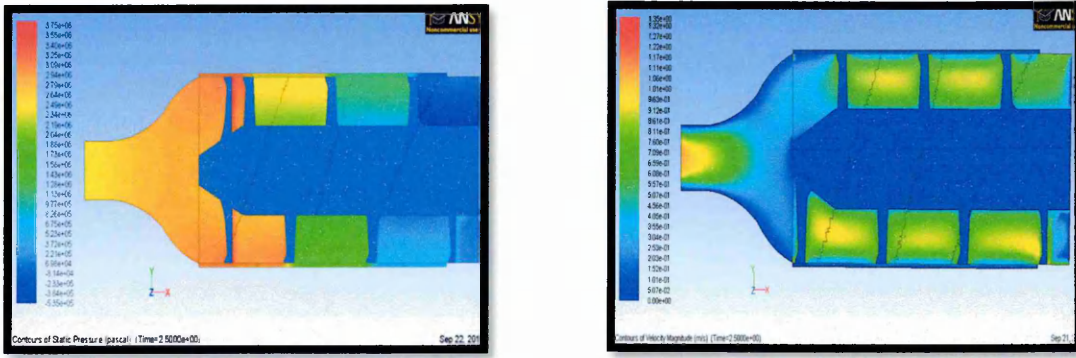

Figure 76: Pressure and Velocity profiles during extrusion [Picture Courtesy of Saravana Kumar Kandasamy]

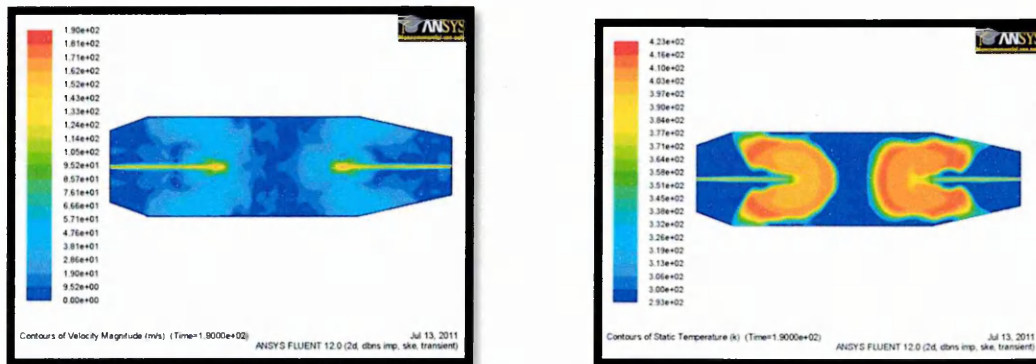

Figure 77: Velocity and Temperature profiles during steam injection in autoclaves [Picture Courtesy of Saravana Kumar Kandasamy]

7.5 Conclusion

The work carried out on this particular machine exhibits the importance of CAE application in an engineering business. Most of the bespoke engineering business like Joseph Rhodes subcontract 60% of their work which involve CAE application and this particular work proved that the in-house activity could save time and cost. As explained in section 7.3, the quotation acquired in 2008 for the conversion and the comparisons are detailed in the above table. In overall, 6.22% savings was achieved in a typical conversion 2D to 3D drawing job with an investment of £7,400 as a software cost. This gives 202.3% rate of return with a payback period of less than 1 month.

CHAPTER 8 - DISCUSSION AND CONCLUSION

8.1 Discussion

As in the research outline, in mid 1980's there was much speculation regarding the benefits achieved from the use of advanced Computer Aided Engineering Methods. However, due to fast growth in technology and despite 2008 global economic crisis, bespoke engineering businesses like Joseph Rhodes have proved their standing by implementing new CAE techniques. The following four applications are identified and all the major activities carried out to achieve the results which influence the company's productivity by reducing the lead time and cost:

1. Design Methods - 2D to 3D CAD Modelling
2. Material Optimisation - Finite Element Stress Analysis Techniques
3. Machine calibration - Dynamic Simulation techniques
4. Sales and Marketing - 3D Drawing and Animation

Implementing these factors will lead to cost benefits in terms of time and material savings; also on the other hand it will be very useful to develop the business to a larger scale. Always the transition should be treated as the learning curve with a minimum attention and as soon as the transition finishes, the payback period starts.

Proper training period needs to be allocated in various stages of the process and there should be a trial run period for avoiding delays in the work-in-progress activities. This will then give the user a complete understanding of the process and improves their confidence in using the system.

Table 36, gives the complete picture of the Cost Benefits due to CAE Implementation in Joseph Rhodes during the two year KTP projects between Joseph Rhodes and Sheffield Hallam University.

Table 36: Cost Benefits - Joseph Rhodes

Press	Typical Contract Value	Investment	Cost Before CAE Implementation	Cost After CAE Implementation	Savings	Savings	Rate of Return	Pay Back Period	Refert
	£	£	Time and Material of the Parts used for 3D Modeling, FEA calculation and Dynamic Simulation	Time and Material of the Parts used for 3D Modeling, FEA calculation and Dynamic Simulation	£	£	%	Months	
Software Selection	Difference Between Solid Works and Inventor upgrade from AutoCAD				£20,300.00				Table
Rubber Die Press	£1,000,000.00	£7,400.00	£137,250.00	£89,250.00	£48,000.00	4.80%	548.65%	3	Table and
KJ and HME Minting Press	£250,000.00	£1,350.00	£34,545.00	£11,170.00	£23,375.00	9.35%	1631.48%	1	Table and
Craven's Extruder	£360,000.00	£0.00	£28,000.00	£5,625.00	£22,375.00	6.22%	202.36%	1	Table
Total	£1,610,000.00	£8,750.00	£199,795.00	£135000.00	£114,050.00		1203.43%		

Cost Benefit Analysis of CAE Implementation

8.2 Conclusion

The results achieved in a joint partnership KTP project between Joseph Rhodes Limited and Sheffield Hallam University have been identified as substantial and indicate considerable direct benefits in implementing advanced CAE techniques into a bespoke engineering business in terms of minimum lead time and cost. However apart from the direct savings there has been an increase in order winning capability due to the improvements in quotation/tendering procedures using CAE tools. The project started in June 2007 and ended in June 2009, where the global economic crisis 2008 threatened the engineering businesses. Despite of economic crisis, the project contributed significant amount to the company's annual turnover.



Figure 78: KTP AWARDS

The following are the main outline of the partnership project:

- ▲ On Completion, the project was graded A and awarded Best KTP project (Figure 78) for the North East England in October 2011 at Innovate 11 event organized by Technology Strategy Board.
- ▲ On completion, the KTP was judged to be responsible for a £114k increase in profits across the company with rate of return of over 1000%
- ▲ 3D concept sketches and 3D animation were fundamental in securing £13m worth of orders for two superplastic forming / diffusion bonding press machines from BAE Systems, Salmesbury.
- ▲ In 2008 Joseph Rhodes was awarded the MWP Award for the Best metal forming machine Mach exhibition, Birmingham, UK.
- ▲ In 2010 Joseph Rhodes was awarded the Queen's Award for Enterprise in the innovation category, specifically for their range of aerospace machinery.

-
- ▲ The company has formed a day-to-day working relationship with the University, drawing on advice and expertise in a number of areas – from stress analysis to use of consultancy facilities.
 - ▲ Three postgraduate projects have been established at the University; the program has also seen extended analysis of products using simulation tools, which will be very helpful to teaching; some simulations will be used to explain manufacturing process to students.

References:

1. Akman, V., Hagen, P. J. and Veerkamp, P. J., 1989. *Intelligent CAD Systems II: Implementational Issues*. Berlin: Springer-Verlag.
2. Alavala, C. R., 2008. *CAD/CAM: Concepts and application*. New Delhi, India: PHI Learning Pvt. Ltd.
3. Autodesk. [Online] Available at: <http://www.autodesk.com> [Accessed 12 December 2010].
4. Armstrong, J., 2008. *Design Matters: The organisation and principle of engineering design*. London: Springer-Verlang London Limited.
5. Autodesk Inventor, 2006. *Using Dynamic Simulation to Improve*, USA: Autodesk, Inc..
6. Baker, H. K. and Powell, G. E., 2005. *Understanding of Finacial Management*. Malden, MA: Blackwell Publishing.
7. Bathe, K. J., n.d. *What can go wrong with FEA*. [Online] Available at: <http://www.memagazine.org/backissues/membersonly/may98/features/wrong/wrong.html> [Accessed 17 January 2009].
8. Black, R., 1996. *Design and Manufacture: An integrated approach*. Hampshire, RG21 6XS and London: MacMillan Press Limited.
9. Bolt, F., 2005. *Professional Issues in Information Technology*. Wilshire, UK: The British Computer Society.
10. Bone, J., 1994. *Oppurtunities in CAD/CAM careers*. Illinois, USA: VGM Career Horizons, A Division of NTC Publishing Group.
11. Braha, D. and Maimon, O., 1998. *A mathematical theory of desing foundations, algorithms and applications. Series: Applied optimization*. New York: Springer.
12. Bronikowski, R. J., 1986. *Managing the engineering design function*. New York: Van Nostrand Reinhold Compant Inc.
13. Cadazz: *CAD History*. [Online] Available at: <http://www.cadazz.com/cad-softwae-history.htm> [Accessed 12 November 2010].
14. *Coins Theory: Rate of Return vs. Risk*. [Online] Available at: <http://www.coin-investments.com/coins-theory/rate-of-return-vs-risk> [Accessed 24 August 2010].
15. Childs, P. R., 1998. *Mechanical Design*. London: Arnold publishers.

-
16. Culley, S., 2001. *Design Research: Theories, Methodologies, and Product Modelling, Book 1*. London, UK: Professional Engineering Publishing.
 17. Dasgupta, A. K. and Pearce, D. W., 1972. *Cost Benefit Analysis: Theory and Practice*. 1 ed. London and Basingstoke: The McMillan Press Ltd..
 18. DeFusco, R. A., McLeave, D. W. and Pinto, J. E., 2007. *Quantitative Investment Analysis*. 2 ed. Hoboken, NJ, USA: John Wiley and Sons Inc.
 19. Dukkupati, R. V., Rao, M. A. and Bhat, R. B., 2007. *Computer aided analysis and design of machine elements*. New Delhi, India: New Age International.
 20. Dym, L. C. and Little, P., 2004. *Engineering Design: A project-based introduction*. Somerset, NJ: John Wiley and Sons, Inc.
 21. Eder, W. E. and Hosnedl, S., 2007. *Design Engineering: a manual for enhanced creativity*. London: CRC Press / Taylor and Francis.
 22. Eide, A. R., Jenison, R., Northup, L. L. and Mashaw, L., 2001. *Introduction to Engineering Design and Problem Solving*. 2 ed. Singapore: McGraw-Hill.
 23. Geddes, R., 2002. *Valuation and Investment Appraisal*. Kent, UK: Financial World Publishing Ltd..
 24. Green, R., 2007. *Expert CAD Management: The complete Guide*. Indianapolis, Indiana: Wiley Publishing Inc..
 25. Group, A., 2006. *The transition from 2D drafting to 3D modelling-benchmark report*, Boston, Massachusetts: Aberdeen Group, Inc.
 26. *Hub Pages: Computer Aided Engineering (CAE)*. [Online] Available at: <http://hubpages.com/hub/CAE-ComputerAidedEngineering> [Accessed 8 September 2010].
 27. Hancq, A. D., *Fatigue Analysis Using ANSYS*. [Online] Available at: <http://www.ewp.rpi.edu/hartford/~ernesto/F2008/MEF2/Z-Links/Papers/Hancq.pdf> [Accessed 16 March 2009].
 28. Howarth, J. and Langford, J., 2004. *Technical Note about KJ-35 press balancing*, Wakefield, UK: Scientific Generic Ltd..
 29. Hsu, T. R. and Sinha, D. K., 1991. *Computer Aided Design: An integrated approach*. New York, USA: West Publishing Company.
 30. Idowu, S. O. and Louche, C., 2011. *Theory and Practice of corporate social responsibilities*. Berlin, Heidelberg: Springer - Verlag.

-
31. Jusko, J., 2007. *IndustryWeek*. [Online] Available at:http://www.industryweek.com/companies-amp-executives/2007_iwmpi-census-whos-using-cad-cae [Accessed 08 September 2010].
 32. *Knowledge Transfer Partnership*. [Online] Available at: <http://www.ktponline.org.uk> [Accessed 12 December 2010].
 33. Knight, F. H., 1921. *Risk, Uncertainty and Profit*. 1 ed. Boston, MA: Hart, Schaffner and Marx; Houghton Mifflin Co..
 34. Lamit, L. G., 2007. *Moving from 2D to 3D CAD for engineering design: Challenges and opportunities*. USA: Book Surge LLC.
 35. Lascoe, O. D., 1998. *Handbook of Gavrication Processes*. Metal Park, OH: ASM International.
 36. Layard, R. and Glaister, S., 1994. *Cost Benefit Analysis*. 2 ed. Cambridge, UK: Cambridge University Press.
 37. Maylor, H., 1997. Concurrent new product development: A empirical assessment. *International Journal of Operations and Production Management* , 17(12).
 38. McAllister, E. W. and Editor, 2009. *Pipeline rules of thumb: Handbook*. 7 ed. USA: Gulf Professional Publishing.
 39. McCosker, P., 1996. The financial evaluation of capital projects. *ACCA students newsletter*, p. 54.
 40. Medland, A. J. and Burnett, P., 1986. *CAD/CAM in practice: A manager's guide to understanding and using CAD/CAM*. London, UK: Kogan Page Limited.
 41. Meguid, S. A., 1987. *Integrated Computer- Aided-Design of mechanical systems*. Essex, England: Elsevier Applied Science Publisher's Ltd..
 42. Mishan, E. J. and Quah, E., 2007. *Cost Benefit Analysis*. 4 ed. London and New York: Routledge, Taylor and Francis Group.
 43. Pahl, G. and Beitz, W., 1988. *Engineering Design: A systematic approach*. London: British Council.
 44. Parameswaran, M. A., 2004. *An Introduction to Design Engineering*. Pangbourne: Morgan and Claypool.
 45. *Return on Investment: What is ROI analysis?*. [Online] Available at: <http://www.solutionmatrix.com/return-on-investment.html> [Accessed 13 May 2010].
 46. Ramakrishnan, K., 2007. *Cost Estimation and Comparision*. Warwick, UK, Knowledge Transfer Partnership.

-
47. Raphael, B. and Smith, I. F., 2003. *Fundamentals of Computer-Aided Engineering*. West Sussex, UK: John Willey and Sons Ltd..
 48. Reid , I. R., 2007. *Knowledge sharing Engineer - To - Order (ETO) manufacturing enterprises* , Sheffield: Sheffield Hallam University (PhD Thesis).
 49. Rhodes, G., n.d. *Corporate Profile Catalogue*. [Online] Available at: http://www.grouprhodes.co.uk/006_irhodes.php [Accessed 8 November 2009].
 50. Roy, 2006. *Standards and regulations useful to mechanical engineers*. [Online] Available at: http://www.roymech.co.uk/Refer_Docs/Stand_Reg_Design.html [Accessed 09 January 2011].
 51. Technology., 2005. answers.com. [Online] Available at: <http://www.answers.com/topic/sheet-metal-forming> [Accessed 28 December 2011].
 52. *SolidWorks*. [Online] Available at: <http://www.solidworks.co.uk> [Accessed 12 December 2010].
 53. Schaefer, D., 2006. Electrical engineering CAD: A new generation of ECAD/ECAE systems. *Journal of Institution of Engineering Designers*, 32 (5), pp. 12-16.
 54. Sherwin, K., 1982. *Engineering Design for Performance*. New York: Halsted Press.
 55. Shim, J. K., Siegel, J. G. and Dauber, N., 2008-2009. *Corporate Controller's: Handbook of Financial Management*. 2 ed. New York, USA: Prentice Hall PTR.
 56. Short, C., 2001. Human Factor Influences on effective Computer Aided Design Implementation. *PhD Thesis, Sheffield Hallam University*.
 57. Simmons, C. H., Maguire, D. E., Phelps, N. and Ien, 2009. *The Manual of Engineering Drawing: a guide to ISO and ASME Standards*. 3 ed. London, UK: Library of Congress Cataloging-in-Publication Data.
 58. Simon, A. H., 1975. *A Student's Introduction to Engineering Design*. USA: Pergamon Press.
 59. Spiewak, S. A. and Weiss, L., 1954. *Cogeneration and small power production manual*. 5 ed. Liburn, GA: The Fairmount Press Inc.
 60. *The Carson City Mint: The Mint of the Wild American West*. [Online] Available at: <http://www.us-coin-values-advisor.com/carson-city-mint.html> [Accessed 11 February 2011].
 61. Tantoush, T., Clegg, . S. and Wilson, F., 2001. CAD CAM intergration and the practical politics of technological change. *Journal Organizational Change Management*, 14(1), pp. 9-27.

-
62. Tschaetsch, H., 2006. *Metal Forming Practise: Processees machines tools*. Berlin: Springer-Verlag.
 63. Twiss, B. C., 1926. *Business for Engineers: Management of Technology series*. London, UK: Peter Peregrinus Ltd..
 64. University, S. H., n.d. *Sheffield Hallam University*. [Online] Available at: <http://www.shu.ac.uk> [Accessed 12 December 2010].
 65. Valberg, S. H., 2010. *Applied Metal Forming: Including FEM Analysis*. New York, NY: Cambridge University Press.
 66. Volland, G., n.d. *Engineering by design*. Boston, USA: Addison Wesley Longman Inc..
 67. Wainright, C., 1995. Design: A missing Link in manufacturing strategy. *World Class Design to Manufacture*, 2(3).
 68. Wells, P., 1998. *Understanding Animation*. London, UK: Routledge.
 69. Wickens, J. M., 1996. *The production of Ancient Coins*. [Online] Available at: <http://www.lawrence.edu/dept/art/buerger/essays/production.html> [Accessed 16 January 2011].
 70. Wright, M. G., 1973. *Discounted cash flow*. 2 ed. London, UK: McGraw-Hill.
 71. Younis, W., 2009. *Up and running wiht audtodest inventor simualtion 2010*. London, UK: Butterworth-Heinemann.

Appendix -1

JOSPEPH RHODES - CUSTOMER SATISFACTION LETTER

Aircelle Ltd
Bancroft Road,
Burnley,
Lancashire,
BB10 2TQ
(+44) 01282 419300

18 March 2010

Mr P. Anderton
Joseph Rhodes Limited
Elm Tree Street
Belle Vue
Wakefield
West Yorkshire
WF1 5EQ

Rhodes 1060MN Flexible Die Press

Dear Peter,

Following the very successful completion of the Rhodes 1060MN Flexible Die Pad Press installed here at Aircelle Burnley site, we would like to offer our reasoning for choosing Joseph Rhodes for the complete design, manufacture and installation of the 1060MN Flexible Die Pad Press.

From the start of the project Aircelle felt that Joseph Rhodes demonstrated that they had a wealth of experience in the area of complex metal forming, and the specific requirements regarding quality and product manufacture within the aerospace industry, and were capable of producing a state of the art metal forming machine that would meet Aircelle's exacting specification.

Out of four potential suppliers, Joseph Rhodes complied with Aircelle's requirements / specification and surpassed other suppliers in the following areas:

- Single large diameter ram (preventing table tilt during forming and cylinder wear)
- Twin ram assist cylinders (for fast approach and low pressure forming)
- Low pressure forming capability
- High pressure forming capability
- Fast and Slow speed forming capabilities
- Pressure hold facility (dwell, variable time capability at any pressure)
- Maximum surface forming pressure of 454 bar (10672 ton, 6538 psi)
- Quick change over of Rubber Die Pad (1 hour change over)
- Flexible Rubber pad changeover spares cost (most economical)
- Longer Rubber pad life (in excess of 250,000 cycles)
- Press daylight of 500 mm (easier access for maintenance and cleaning)
- Quick change-over pressure pad increasing surface forming pressure to 1000 bar maximum (for forming titanium alloys)

- Press design includes capability of two/ four loading stations for increased productivity
- High pressure hydraulic system via direct pumping (no accumulator required)
- Fully integrated acoustic panelling for noise reduction and operator health and safety
- Fully interlocked machine enclosure for maintenance access and operator health and safety
- Extended warranty period
- Shortest manufacturing lead time
- Excellent service and support

Joseph Rhodes technological capabilities and willingness to work with Aircelle Facilities Engineers to introduce new technologies on the 1060MN Flexible Die Pad Press resulted in the machine winning the “BEST METAL FORMING FABRICATION AWARD” at the MACH 2008 show sponsored by Siemens.

The 1060MN Flexible Die Pad Press has been in production at Aircelle Burnley site for 12 months, resulting in improved operating efficiencies, reduced re-work of sheet metal components, and an increased level of quality in production of components produced by Flexible Die Press Manufacture. The 1060MN Flexible Die Pad Press has performed with maximum up time (zero breakdowns).

The 1060MN Flexible Die Pad Press is viewed by Aircelle Burnley Site as being a very successful procurement project, benefiting the Aircelle Burnley business with an enhanced capability of winning new programs and reducing our manufacturing cost base.

Aircelle would like to thank Joseph Rhodes for an excellent project, well done.

Regards

Yours Sincerely



Mr M. Mitchell
Facilities & Capital Assets Manager

Appendix -2

JOSEPH RHODES - CATALOGUES AND NEWS LETTERS

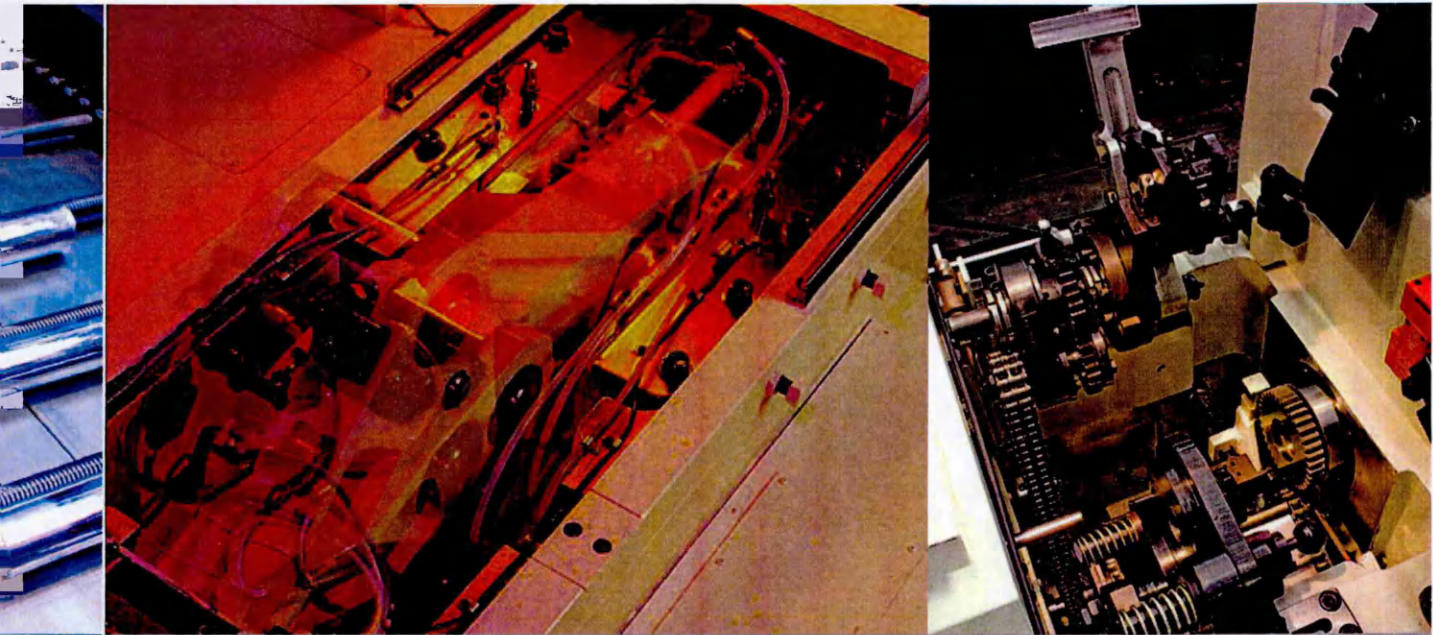

Special Purpose Machinery
for Aluminium Tube and
Can Manufacture



IMPACT EXTRUSION PRESSES

Press Manufacture

We offer over 180 years of experience in the manufacture of special purpose mechanical and hydraulic presses for metalforming applications around the world.

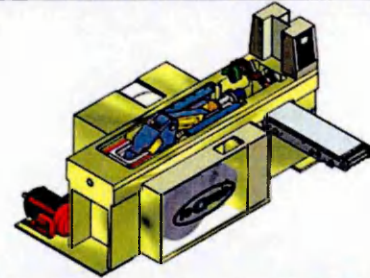

Joseph Rhodes Limited is one of Europe's leading manufacturers of CNC metalforming machinery and a specialist in the bespoke design of mechanical and hydraulic presses. A major part of the Company's product portfolio is probably the world's largest range of Horizontal Impact Extrusion Presses, with over 250 machines operating in 40 countries worldwide.

The award winning* Rhodes 'KJX' Series of extrusion presses offer machines from 5 to 1000 tonnes capacity for the high-speed production of both collapsible tubes and rigid aerosol cans, thereby enabling the correct press to be chosen for each particular application. All KJX Horizontal Extrusion Presses can be supplied with non-standard slide strokes to suit any length of tube or can being produced.

Operating from an 8-acre site in Wakefield, England, with over 15,000 sq. metres of factory space under crantage, the Company's extensive fabrication, machining and assembly departments ensure that all aspects of machine build are controlled to Joseph Rhodes quality (ISO 9001:2000), environmental (ISO14001:2004) and European (CE) Accreditations.

Joseph Rhodes design and manufacturing facilities enable the Company to offer a total service from initial concept through to site installation and commissioning. All major research and development work for the KJX range is conducted in-house and is supported by a well equipped Computer Aided Design Department covering mechanical, electrical, hydraulic and software engineering disciplines.

COMPLETE INTEGRATED SYSTEMS

To complement its range of individual extrusion presses, Rhodes has also designed and manufactured a range of integrated manufacturing systems for the blanking of aluminium and zinc slugs.

Rhodes successful high speed battery production system KJX-RT4 (Press and Trimmer) is capable of extruding, trimming and beading Zinc battery cases at a rate of up to 280 cases per minute.

Main (left): Aerial photograph of the Company's Wakefield site.

Top: The latest 3D CAD and Finite Stress Analysis technology is used in the design of new KJX Extrusion Presses.

Bottom: One of a line of Rhodes KJX extrusion presses in operation at a customer's site in Asia.

BENEFITS OF RHODES IMPACT EXTRUSION PRESSES

- The latest Rhodes KJX Extrusion Presses have been specifically designed and developed for continuous high-speed operation with complete reliability.
- A new and improved linkage arrangement ensures that inertia forces within the press are reduced to a minimum.
- The AC variable speed drive motor, available as standard, makes automatic speed change quick and repeatable.



KJX Design Features

Utilising state of the art technology, perfected over years of in-house research and development, the award winning KJX extrusion presses have been designed to provide smooth and balanced running at high production speeds.

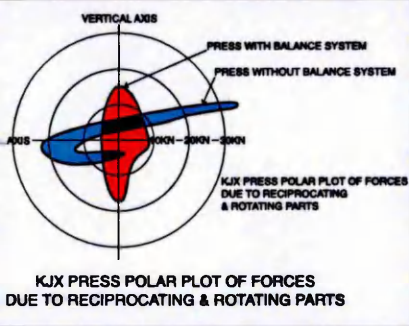
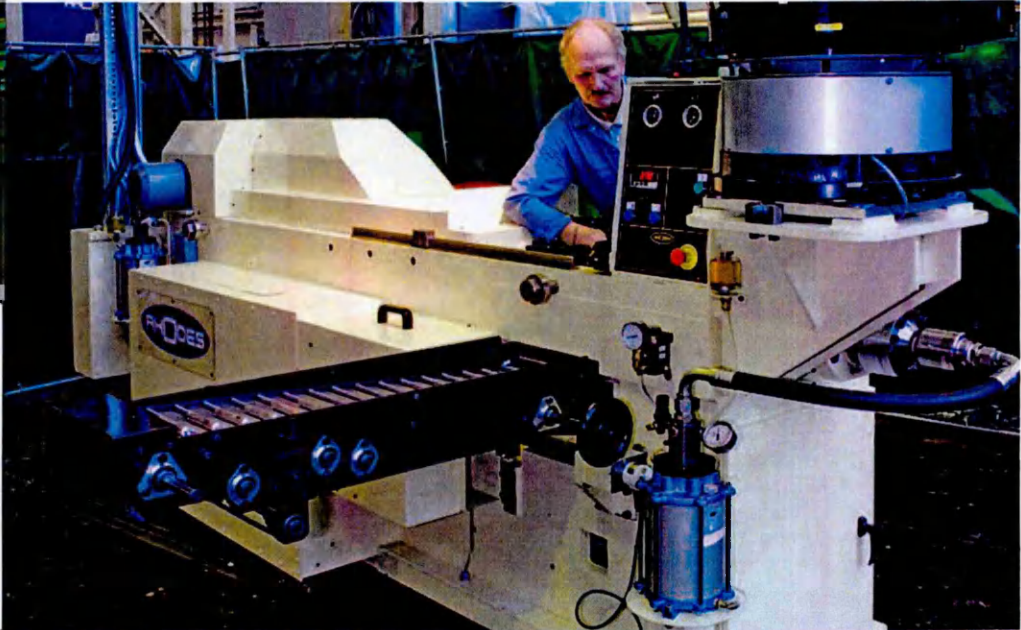
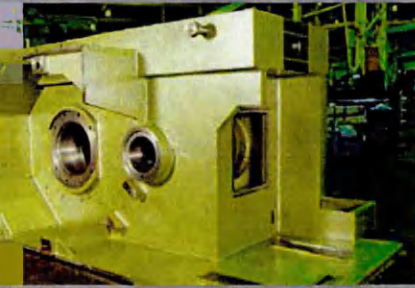

In (right): KJX extrusion press undergoing final trials prior to dispatch.

Top: A one-piece steel fabricated frame for a KJX.63S.

Bottom: KJX press polar plot of forces due to reciprocating & rotating parts. All KJX models utilise the Rhodes Dynamic Balancing system (plot shown in Rhodes).

All KJX Presses (except the smaller KJX.25 model) are designed with dual balancing systems to ensure smooth operation free running at high production speeds.

The ergonomically redesigned tool-space area with improved accessibility makes KJX presses a popular choice with machine operators.

State of the art design features include PLC as standard and motorised slide adjustment as one of many options available.

PRESS CONSTRUCTION

As with all Rhodes machines, the design and strength of the main frame is an important factor in ensuring precise component production and press stability at high speeds.

All KJX Presses, up to and including the model no. KJX.63, have a rigid, one-piece steel fabricated frame which is fully stress relieved in-house. Press models KJX.75 and above are of a multi-piece frame construction, locked together by pre-stressed tie-bars, thereby reducing deflection to a minimum.

LINKAGE

Rhodes unique linkage design reduces stress and shock loads within the press. The knuckle links are manufactured from fully machined forgings of a high tensile alloy steel and are mounted in knuckle type Nickel Alloy Bronze high wear resistant bearings, with adjustable steel bearing blocks.

CRANKSHAFT

To ensure smooth running and minimum vibration, the crankshaft and knuckle linkage are dynamically balanced.

The crankshaft itself is machined from a forging of high tensile alloy steel and is supported by precision phosphor bronze bearings.

PRESS BALANCE

All high-speed extrusion presses, except the KJX.25 model, incorporate a dual balance system to reduce the forces produced by the reciprocating slide and linkage mechanism. The KJX.25 is fitted with its own unique balancing system appropriate for the pressure capacity applied.

CLUTCH AND BRAKE

Rhodes KJX Presses are fitted with the highly successful "Ortlinghaus" combined pneumatic friction clutch and brake unit.

**Best Metalforming Machine Tool"
MACH International Machine Tool
Awards (sponsored by MWP).



Quality Engineering

Joseph Rhodes has a reputation in the market place not only for the technical and innovative nature of its products, but also for the workmanship, longevity, service and finish of its machinery.

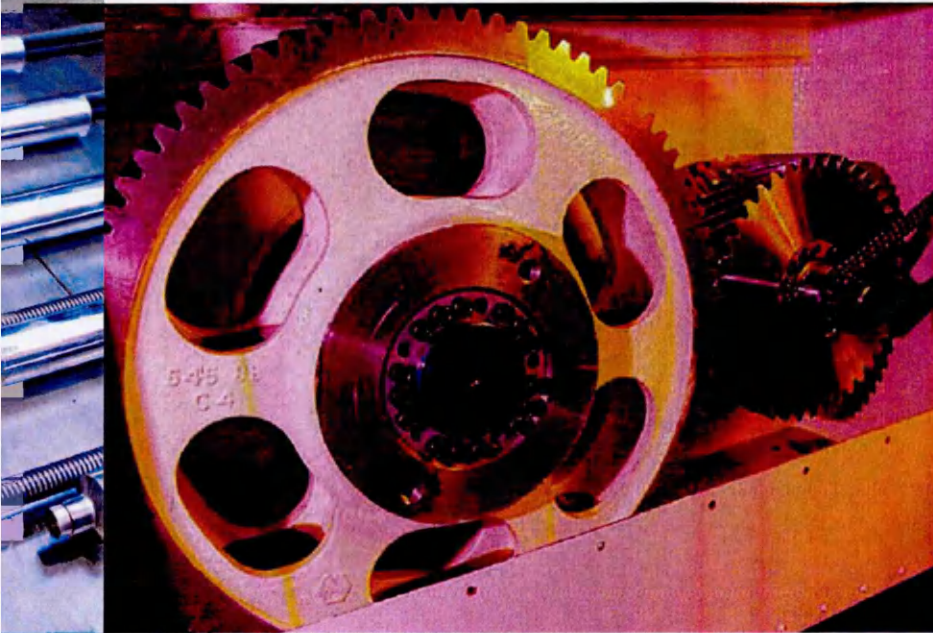

GEARS

Precision engineered double helical gears rotating in a sealed oil bath are used throughout, each gear being attached to its respective shaft by frictional taper locking assemblies.

CAN TAKE-OFF SYSTEM

Both the stripper bracket and the extrusion take-off system are designed to pivot clear of the tool space area for ease of access. The component removal arm is directly driven from the press crank shaft to ensure precision timing and incorporates independent adjustment for smooth operation.

The conveyor drive is protected by an overload clutch which can, in the event of an overload, be reset by a handwheel.

LUBRICATION

The fully automatic "fullflow" recirculating oil lubrication system operates using internally machined oilways and static pipework, thereby totally eliminating the need for vulnerable flexible pipework.

The motor driven gear pump is fitted with a suction strainer and the system also incorporates a pressure regulator, pressure gauge, low pressure switch and a high pressure fine micron filter.

To eliminate contamination from extrusion lubricant or metallic particles the oil reservoir is isolated from the tool space area.

THE DRIVE

All Rhodes KJX Presses are fitted with an AC variable drive system to facilitate speed changes. The Human Machine Interface (HMI) touch screen control displays current operating speed, and allows speed changes to be made when the press is running in 'automatic' mode.

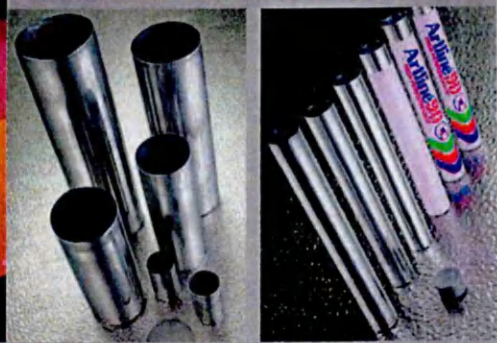
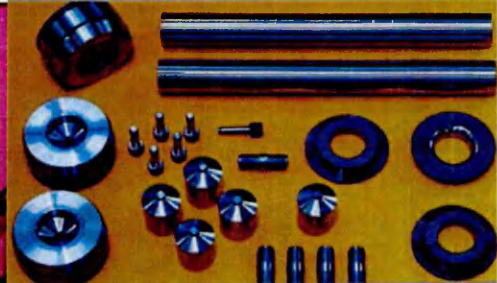

Main (left): Double helical main drive gears.

Top: Joseph Rhodes offer a comprehensive range of tooling for the KJX press range.

Bottom (left): A selection of KJX extruded components used in rigid can production.

Bottom (right): Production stages for marker pens.

Operational Efficiency

In a competitive industry, Joseph Rhodes extrusion machinery gives our customers an efficient route to improved productivity. With over 250 machines in use worldwide, KJX presses have become an industry standard in many market sectors.

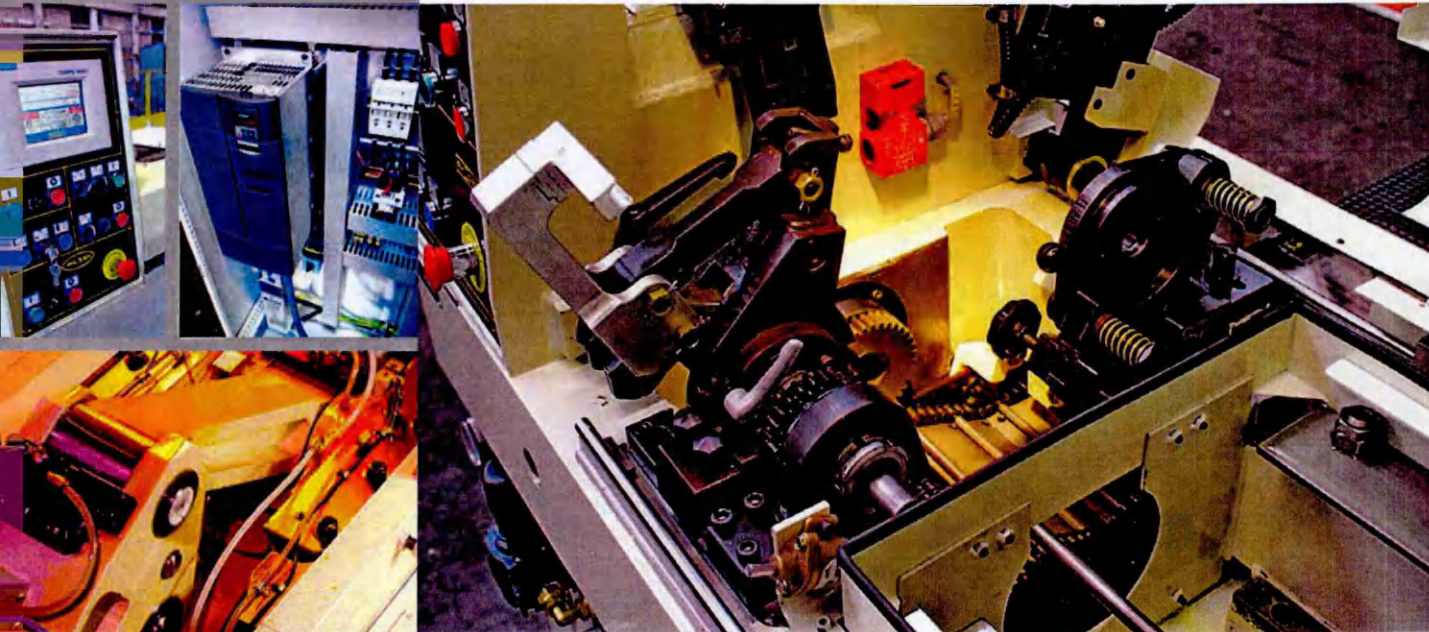

In (right): Tool space area showing feed plate, upper bracket and take-off system.
 (left): Integrated PLC touch screen control. (Also available as a free standing control unit).
 (right): AC main drive motor control.
 Bottom: KJX linkage system.
 Bottom: Slug feed arrangement.

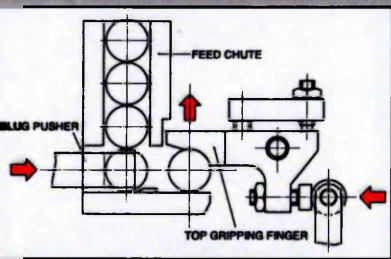

CONTROLS

For ease of operation the main control panel is conveniently located adjacent to the tool area and allows pushbutton initiation of single, continuous or inch cycle. The sub control panel at the conveyor outlet side of the press houses duplicate pushbuttons for start/inch, 'controlled' or 'emergency' stop.

All Rhodes KJX Presses are designed to provide maximum operator safety and prevent any damage to the machine. The press will stop automatically in the event of low air or oil pressure, failure of the extrusion to eject from the die, empty slug feed chute, opening of the tool guard and faults in the main motor fan, flywheel brake, control cabinet and conveyor clutch.

The press electrical control equipment can either be mounted on the press or housed in a freestanding cabinet. (Subject to customer preference).

CONTROL TECHNOLOGY

Using Rhodes' extensive experience of PLC and CNC microprocessor technology, comprehensive systems can be offered to control the machine's major functions, thereby ensuring faster production set up times. Full diagnostics, cam settings, auto wedge positioning and main press speed are amongst the features available through the Siemens PLC based Human Machine Interface (HMI). (Other systems available upon request.)

SLUG FEED SYSTEMS AND TOOLSPACE AREA

A slug feed pusher, operated by a timed cam, moves the slug to the gripping finger(s) which open by means of a rotating cam and pivot lever. The tool space area is designed with operator access in mind. The slug feed mechanism, the extrusion take-off system, and the extrusion stripper plate can all be swung clear of the tool space area, providing uninterrupted access to the extrusion tools and conveyor.

LINE SYNCHRONISATION

The Rhodes Extrusion Press is the first machine in a complex line of automated equipment. The KJX range has therefore been designed to fully integrate with such production lines through the provision of the necessary electrical and/or mechanical interconnection with tube lathes or can trimmers.

"Best Metalforming Machine Tool"
 MACH International Machine Tool
 Awards (sponsored by MWP).



Optional Extras

Joseph Rhodes takes particular pride in its ability to design and manufacture bespoke machinery and complete turnkey solutions. 'Special' extrusion presses can be manufactured to custom specification, and optional extras added where required (see below).

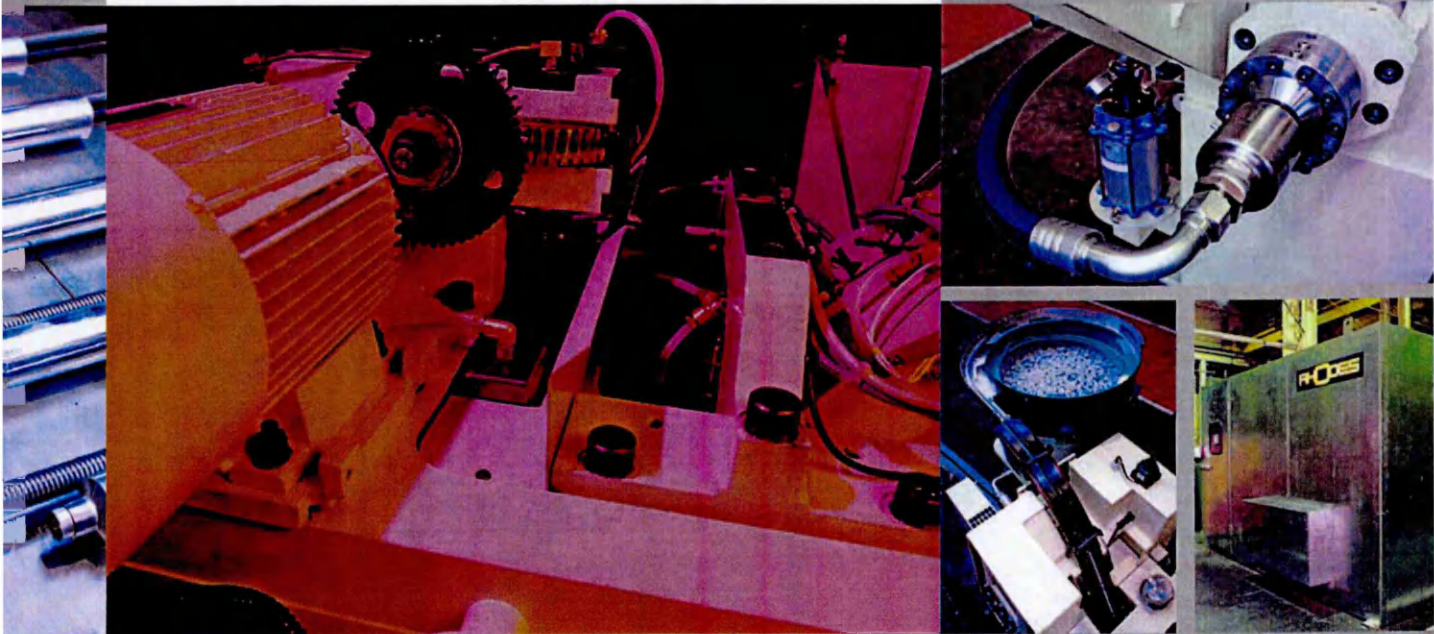

HOPPER ELEVATORS

For use in conjunction with slug bowl feeders, the Rhodes hopper elevators enable press operation over long periods without constant slug replenishment.

MOTORISED SLIDE ADJUSTMENT

The motorised slide adjustment provides rapid and accurate setting of the slide using a two speed motor operated from the press control panel. An electronic digital readout indicator shows the degree of slide adjustment. Fitted as standard with this system is a load measurement unit to indicate press loading and to monitor for tonnage overload on the press.

EJECTORS AND COMPENSATORS

Rhodes offers a full range of adjustable ejectors and compensators, both light and heavy duty for all types of extruded components.

BOWL FEEDERS

The Rhodes KJX range of Presses can be supplied with either vibratory or mechanical rotary bowl feeders, the choice of which depends upon the type of slug being handled.

SOUNDPROOF ENCLOSURES

The Rhodes walk-in acoustic enclosure is specifically designed to reduce noise levels to below 80 dBA. Access doors and force ventilation are provided. All panels are removable.

EXTRUSION TOOLING

Presses can be supplied complete with extrusion tooling to suit DIN standard collapsible tubes or aerosol cans. Rhodes experience in extrusion tool design and application also enables special and non-standard tooling to be quoted.

Main (left): Motorised slide adjustment.

Top: Hydraulic compensator (for membrane nozzle tube production.)

Bottom (left): Vibratory slug bowl feeder.

Bottom (right): Sound reducing enclosure.

TECHNICAL EXTRUSIONS

The KJX range of extrusion presses are used extensively within the Technical Extrusion products market place.

Components manufactured on the KJX range include complex technical housings for automotive, defence and specialist packaging applications.

Product Specification

DETERMINATION OF MAXIMUM EXTRUDED LENGTHS OBTAINABLE

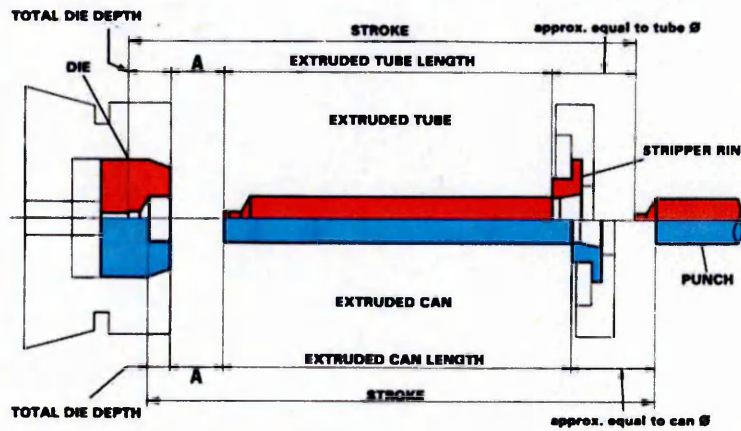

Model No.	Stroke mm)	A
KJX.25	254	25
KJX.35	300	30
KJX.35S	300	30
KJX.50	330	35
KJX.50S	314	35
KJX.50L	381	35
KJX.63	381	38
KJX.63S	280	38
KJX.63L	457	38
KJX.75	457	40
KJX.90	520	45
KJX.120	585	50

EXAMPLE:-
 press model No. KJX.50
 40 mm Ø collapsible tube.
 total die depth - 28 mm.
 Maximum overall extruded length,
 = 330 - (28 + 35 + 40)
 = 330 - 103
 = 227 mm.

This calculation should be used as a guide only



Left: Technical extrusion products.
 Right: A selection of extruded rigid cans.
 Bottom: Production process for rigid cans.

	Zinc			Aluminium												
Model Ref. (Note 1)	KJX 24	KJX 32	KJX 8	KJX 25	KJX 35	KJX 35S	KJX 50	KJX 50L	KJX 50S	KJX 63	KJX 63L	KJX 63S	KJX 75	KJX 90	KJX 120	
Pressure Capacity (Tons)	60	120	5	60	100	100	160	160	200	325	325	325	400	650	1000	
Rating from B.D.C (mm) (Note 2)	5	7.0	4.5	4.5	4.5	9.7	4.5	4.5	7.0	4.5	4.5	8.0	10	25	35	
Stroke (mm) (Note 1)	130	172	102	254	300	300	330	381	314	381	457	280	457	520	585	
Speed (spm)	150/280	150/280	150	80/170	100/200	100/200	80/150	60/120	80/170	60/120	40/80	80/170	40/80	25/50	30	
NB. Higher speeds may be available. Machine speed and capacity requirements vary significantly between specific applications.																
Maximum Ø with 0.12mm Wall (A1.)	-	-	8	25	35	35	50	50	50	63	63	60	75	90	110	
Maximum Ø with 0.30mm Wall (A1.)	-	-	10	30	42	40	56	56	55	73	73	70	87	100	130	
Maximum Ø with 0.30mm Wall (Zinc.)	24 mm	32 mm	-	-	-	-	-	-	-	-	-	-	-	-	-	
Drive Motor (KW)	18.75	37	1.1	10	17.5	30	40	40	48	65	65	80	70	80	120	
Press Weight (Kg)	5800	10000	1000	6000	9500	10200	9500	10000	12400	19000	21000	23000	40000	68000	85000	
OVERALL SIZES (mm) (Note 3)	Length	2100	2770	1375	2870	3340	3350	3470	3760	3650	4200	4650	4000	5100	5950	6550
	Width	1380	1730	610	1310	1980	2000	2310	2310	2090	2170	2170	2610	3050	3500	3950
	Height	1300	1650	690	1520	1550	1550	1750	1780	1830	1920	1920	2170	2400	2850	2960

Notes:

- This specification table is provided as a guide only. Machine speed and capacity requirements vary significantly between specific applications. Please contact our technical sales department for further advice on model selection.
- Rating from Bottom Dead Centre (B.D.C) is the distance (mm) through which maximum pressure capacity can be applied.
- Overall press sizes are approximate.

Data provided in this literature is an approximate guide and shall not be contractually binding. The policy of Joseph Rhodes is one of continuous product development. The right to change specification and design at any time without notice is reserved. 0.2M/1008/A

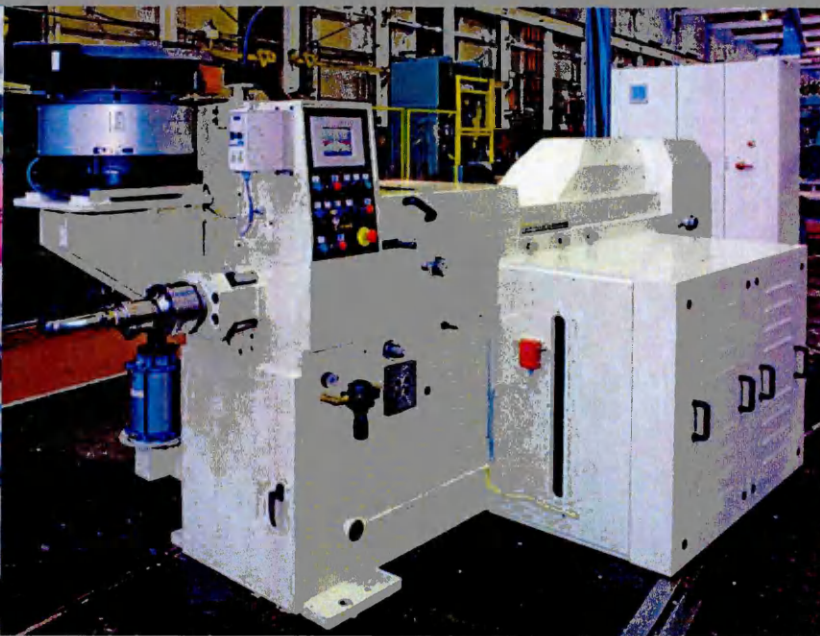

Belle Vue Wakefield WF1 5EQ England

Tel: +44 (0)1924 371161 Fax: +44 (0)1924 370928

E-mail: sales@grouprhodes.co.uk

www.josephrhodes.com

GROUP
RHODES 
Joseph Rhodes is a member
of Group Rhodes



THE QUEEN'S AWARDS
FOR ENTERPRISE:
INNOVATION
2010

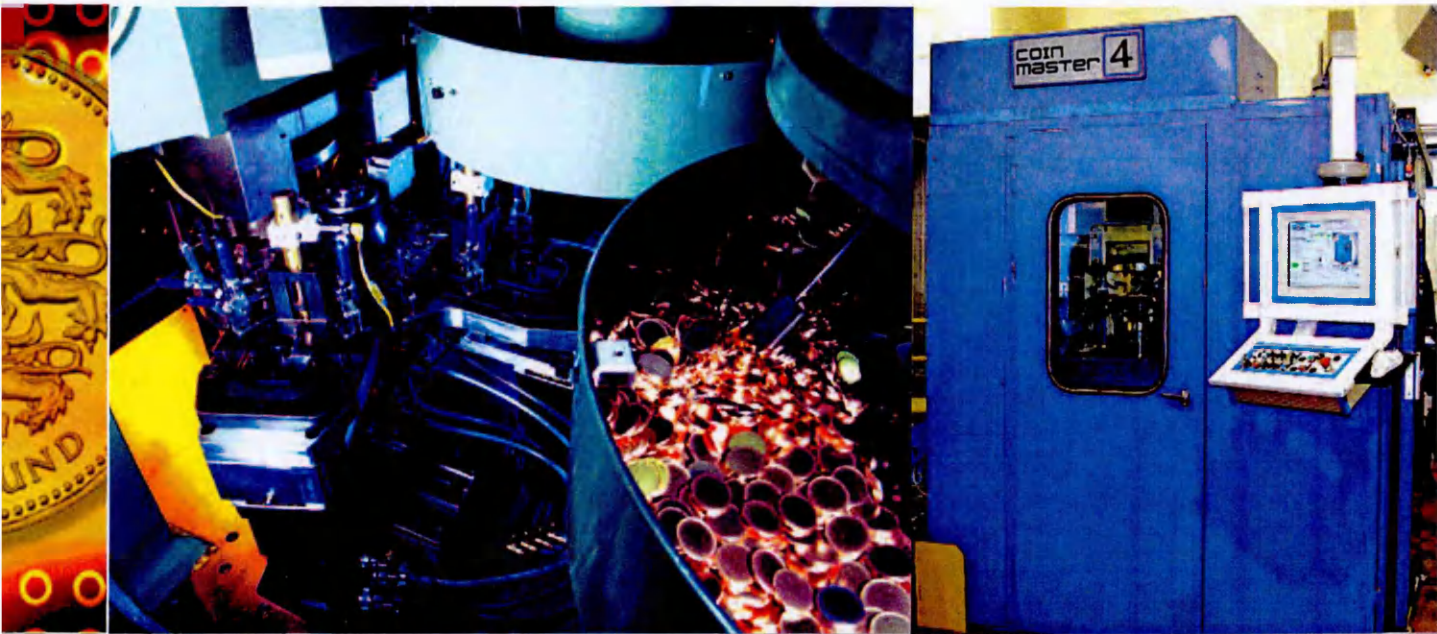

Special Purpose Machinery for the Minting Industry

Coinmaster 4™
*Homogenous and Bi-Metal
High Speed Coining Press*

HME
Minting

Our Minting Heritage

From the early years of automated coin production, HME has offered unrivalled expertise in the supply of Minting Machinery. Today our presses produce precision engineered coins for leading Mints throughout the world.

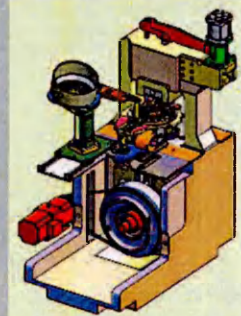
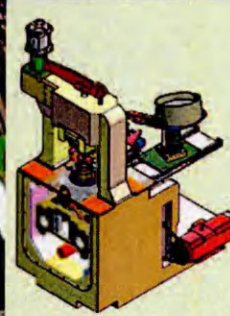

HME MINTING INNOVATION

With in excess of 350 machines sold to over 34 mints worldwide, HME minting presses have an established reputation for offering technical solutions to a wide variety of coining, embossing, forming and sizing requirements.

Extending this reputation into a new era of coining technology, the all new and patented Coinmaster 4™ homogenous and bi-metal coining press sets new standards in minting press performance. Based on the revolutionary new Twin-Link drive system, the Coinmaster 4™ offers fully variable operating speeds of 350 – 850 strokes per minute, state-of-the-art blank control and the latest in networked I/O machine control systems.

The Coinmaster 4™ has been designed in close cooperation with the Royal Mint in order to ensure that it meets the demands of today's modern high speed minting operations. New technologies have been carefully introduced to protect industry standards, thereby ensuring that the new generation of HME Coinmaster™ presses can efficiently operate alongside minting presses of other makes.

SERVICE AND SUPPORT

HME's design and manufacturing facilities enable the Company to offer a total service from initial concept through to site installation and commissioning. All major research and development work for the Coinmaster™ range is conducted in-house and is supported by a well equipped Computer Aided Design Department covering mechanical, electrical, hydraulic and software engineering disciplines.

Main (left): Aerial Photograph of the Company's 8-acre Wakefield site.

Above (Top): Technical Design Department

Above (Bottom): 3D Model of Coinmaster 4™

Below: Lord Digby Jones, UK Minister of Trade, (second left) visits HME to observe the new Coinmaster 4™ minting press.



Key Design Features

Utilising state of the art technology, perfected over years of in-house research and development, HME minting presses have been designed to provide smooth and balanced running at high speeds.

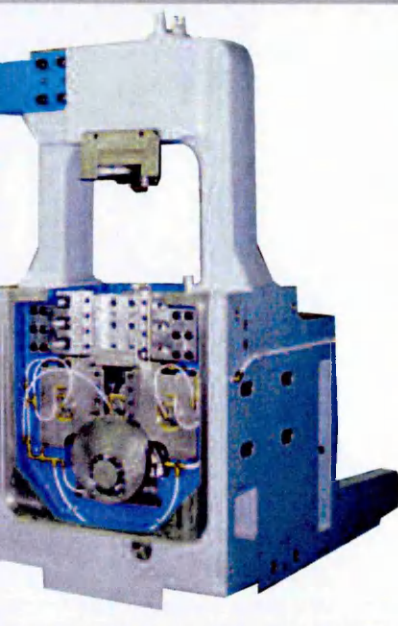

Main (Right): HME Coinmaster 4™ in operation at the Royal Mint in Llantrisant, Wales.

Above: Main frame and Twin-Link mechanism during press build.

Below: Copy of a Patent pertaining to the HME Coinmaster 4™.



HME TWIN-LINK DRIVE SYSTEM

The Coinmaster 4™ is the first commercially available minting press to utilise a link drive system that is inherently balanced throughout its entire operating speed range. This revolutionary Twin-Link mechanism has been designed and engineered by HME to eliminate the harmonic interference under acceleration that is commonly associated with existing "secondary" or counterbalanced machines that utilise knuckle-joint systems.

Following successful operating trials of the mechanism at the British Royal Mint, and enhancements to the lubrication system, motor drive system, and blank pusher mechanism, Coinmaster 4™ has pushed back the productivity boundaries of circulation coin production.

HME PATENTED FEED SYSTEMS

Patents have been granted on new Coinmaster 4™ feed systems, capable of feeding coins at rates far in excess of today's industry standard press speeds.

KEY FEATURES OF THE COINMASTER 4™ INCLUDE:

- New Twin-Link drive ensuring smooth and balanced operation at ALL speeds.
- Near perfect 130° dwell of the Twin-Link mechanism at bottom dead centre allows reliable coin ejection and feeding.
- New mechanical bowl feed system together with an in-line sorter incorporated into the feed system.
- A sixteen-station dial feed plate serviced by a single or dual blank pusher mechanism.
- State-of-the-art blank control, utilising an optimised linear speed profile for moving the blank from the stack into the dial plate.
- Improved pneumatic ejector system.
- Siemens "profibus" networked I/O control system with full colour TFT LCD display.

Highly Commended
"Best Metalforming Machine Tool"
MACH International Machine
Tool Awards



Quality Engineering

HME has a reputation in the market place not only for the technical and innovative nature of its products, but also for the workmanship, longevity, service and finish of its machinery.

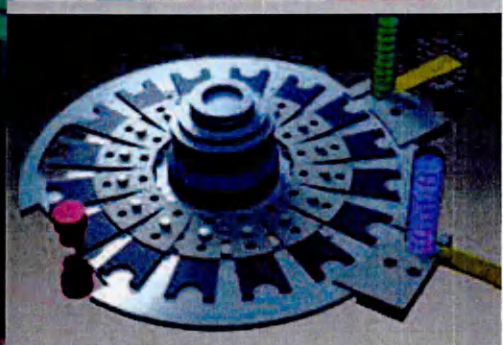
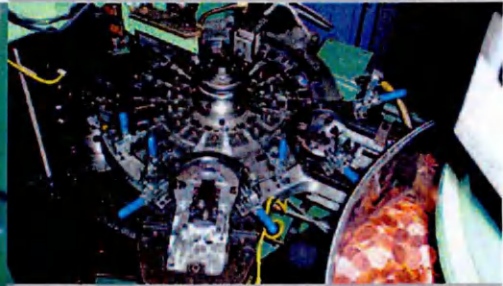
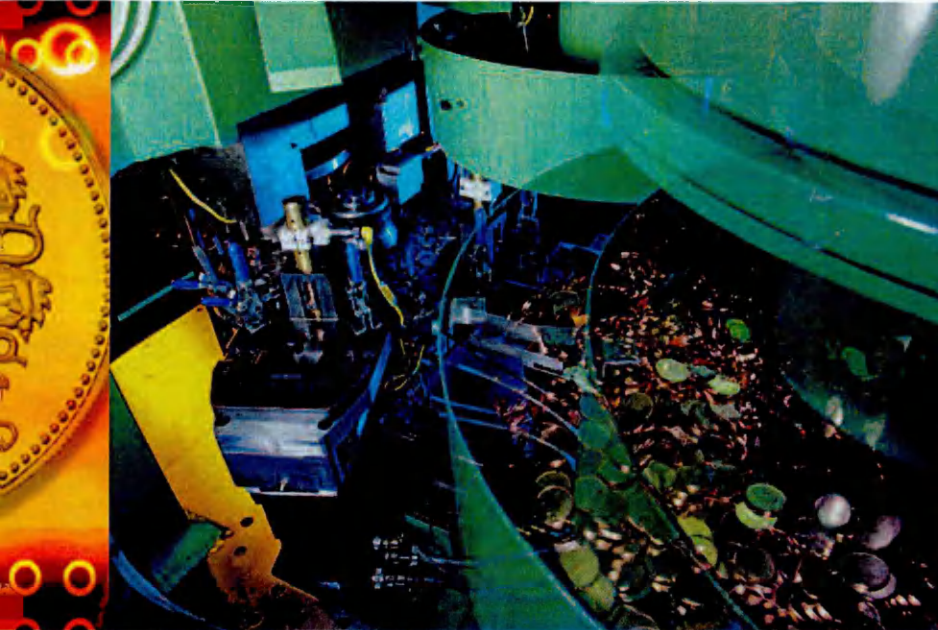

KEY DESIGN FEATURES (CONT)

FRAME

Of heavy-duty one piece, cast alloy steel construction, fully stress relieved before machining for highest accuracy. Compact and space saving frame design analysed using finite element principles to ensure maximum strength with minimum deflection and excellent damping characteristics.

MAIN DRIVE

By means of a AC motor, incorporating infinitely variable speed settings, driving a balanced flywheel by means of a multi-groove belt. The flywheel rotates on anti-friction roller bearings and is supported on a quill rigidly attached to the press frame, thereby avoiding unbalanced crankshaft loading. A 'Crawl' mode is available for tool setting purposes with a cycle speed of 30 strokes per minute.

SLIDE

Constructed of a high tensile high-grade aluminium alloy to give maximum strength and minimum weight. Slide guidance by precision, pre-loaded roller bearings with prismatic adjustment to achieve 'play-free' operation with minimal friction.

TWIN-LINK DRIVE SYSTEM

The Twin-Link drive system has been designed to produce an optimum 'motion profile' for both coining and feeding at high speeds. An exceptional near perfect 130° slide dwell at bottom dead centre allows accurate and reliable coin ejection and feeding. The system also provides for positive contact of all linkage components at all stroke positions.

To further enhance press operating life, the unique Twin-Link drive incorporates full dynamic balancing over the entire speed range, eliminating the need for special foundation requirements.

Main (left): Coin blank feed mechanism for bi-metal coins.

Above (Top): Dual Feed Pusher system with feed tubes removed for illustration.

Above (Bottom): The latest 3D CAD design technology is used in the development of the HME Coinmaster 4™ feed systems.

Below: Twin coin blank feeders on a Coinmaster™ bi-metal press.

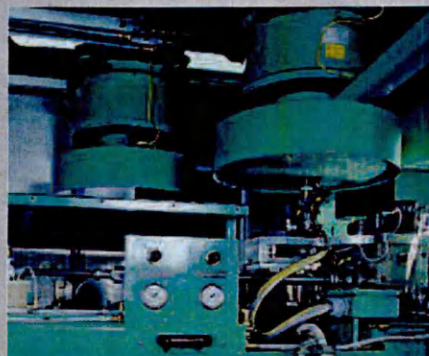

Bi-Metallic Press

Operational Efficiency

In a competitive industry, HME minting machinery gives our customers an efficient route to improved productivity. With over 350 machines sold worldwide, Coinmaster™ presses have become an industry standard in the minting market. The all new Coinmaster 4™ continues this tradition by setting new standards in high speed coin production.

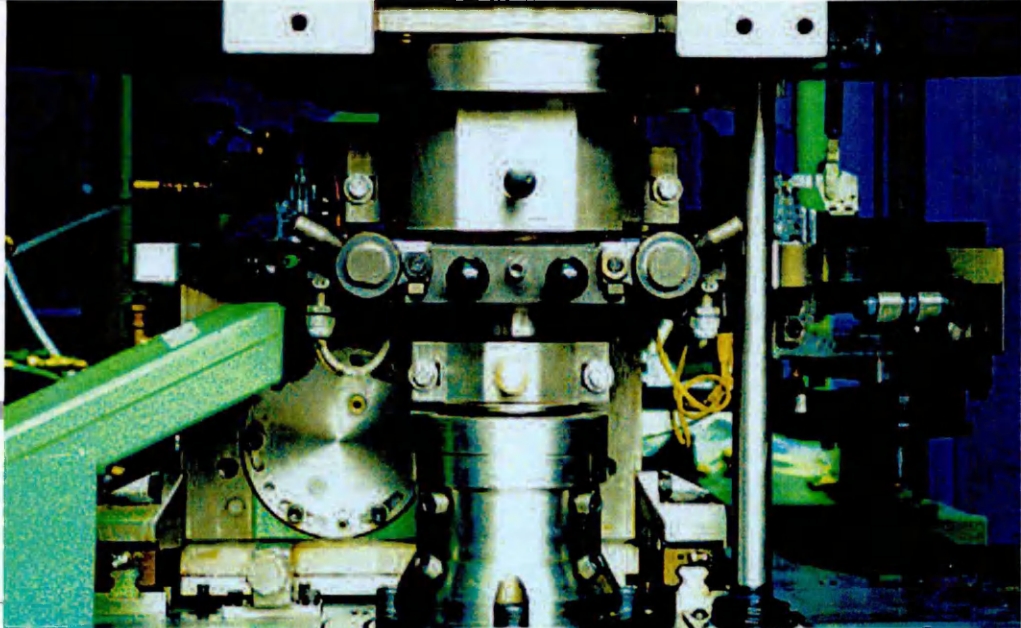
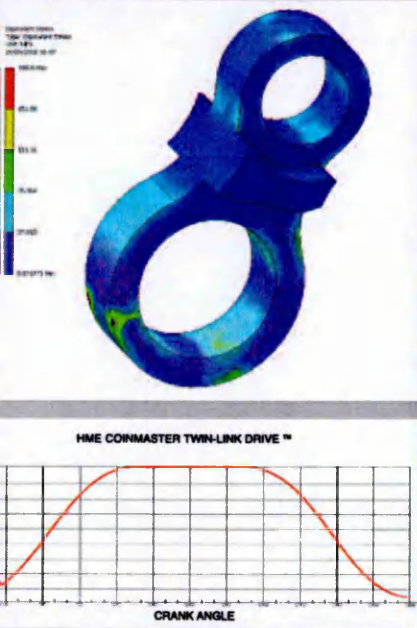

(Right): Tool area of press showing tooling dies and in situ.
 (Top): Stress analysis of upper link.
 (Bottom): Slide displacement graph showing dwell side dwell for reliable coin blank feeding and discharge.

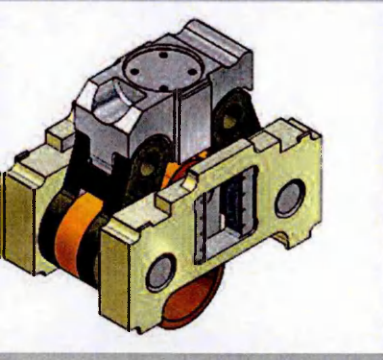

Twin Link System

KEY DESIGN FEATURES (CONT)

CRANKSHAFT BALANCING

The crankshaft runs in maintenance free hydrodynamic 'DYN' alloy phosphor bronze bearings. The rotating crankshaft is fitted with two counter balanced masses to eliminate the force produced by the crank pin and coupling head. The mirror effect design of the Twin-Link drive automatically produces a balanced system. Anti-vibration mounts specifically calibrated and designed are fitted under the feet of the press to prevent forces being transmitted to the factory floor.

LOW INERTIA CLUTCH & BRAKE

High efficiency low inertia combined pneumatic friction clutch & brake unit to achieve immediate motion arrest.

BLANK FEED SYSTEM (HOMOGENOUS AND BI-METAL)

The blank feed mechanism comprises a mechanical rotary bowl feed mounted on pre-loaded linear guide rails enabling the bowl to be retracted for accessibility. The blank discharge chute is adjustable to accommodate varying sizes of blanks and incorporates a blank sorting station to reject rogue blanks. The blanks are channelled into a vertical feed chute from where the bottom blank is fed by a pusher mechanism into the indexing dial plate. The dial plate is equipped with an overload protection system and can be retracted along with the indexing gear to facilitate a die change. (Push button controls). Backlash free indexing gear ensures high positional accuracy. Twin coin blank feed bowls are available for bi-metal coin production. Blank feed change parts are available for alternative diameters of coin blank.

TOOL HOLDERS (COIN PRESS TOOLING)

The tool holders are designed and supplied to suit our customers existing coining tools (dies and collars). The bottom tool holder incorporates both precision spherical alignment and lateral tool adjustments. Both top and bottom coining dies, and collar, are provided with quick release clamping systems to provide a changeover system that ensures minimum press downtime.

Highly Commended
 "Best Metalforming Machine Tool"
 MACH International Machine
 Tool Awards



Optional Extras

HME takes particular pride in its ability to design and manufacture bespoke machinery and complete turnkey solutions. 'Special' minting presses can be manufactured to custom specification, and optional extras added where required.

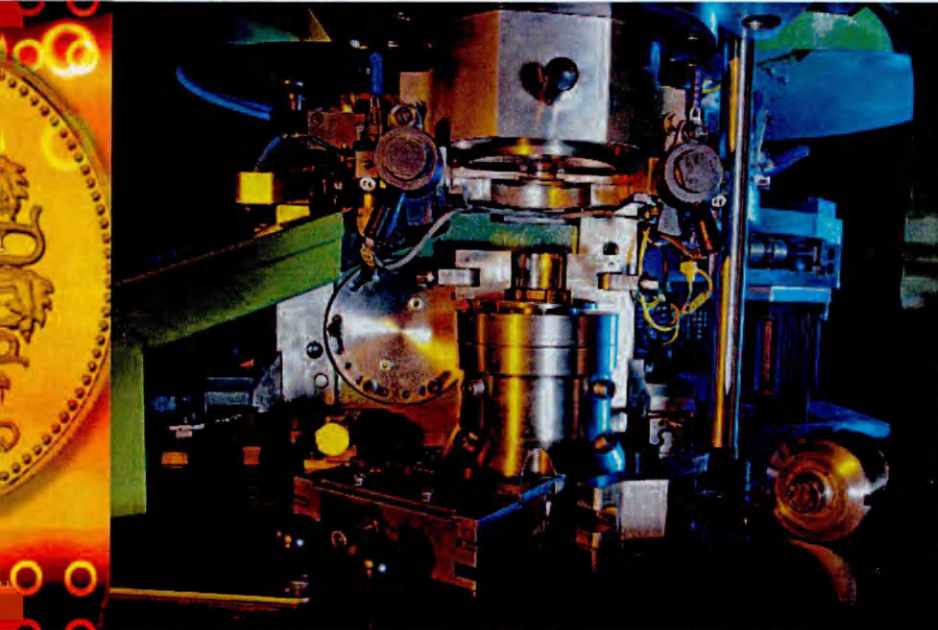

KEY DESIGN FEATURES (CONT)

AUTOMATIC COIN BLANK SORTING MECHANISM

The inclined feed chute from the mechanical rotary bowl blank feed incorporates a coin blank sorting mechanism.

EJECTOR MECHANISM

The ejector system is a pneumatically locked mechanism with pivoting displacement connected directly to the slide. A fine adjusting device is incorporated for accurate setting.

CONTROL TECHNOLOGY

Using HME's extensive experience of PLC and CNC microprocessor technology, a comprehensive system is offered to control all major machine functions, thereby ensuring faster production set up times. Full diagnostics, tool data sets cam settings, auto wedge positioning and press speed are amongst the features available through the Siemens PLC based Human Machine Interface (HMI).

LUBRICATION

Press lubrication is achieved by a fully automatic re-circulating oil system complete with cooling circuit.

ACOUSTIC ENCLOSURE

The machine is provided with an integral Acoustic Enclosure incorporating a forced ventilation system which can be arranged to provide either a positive or negative pressurisation. Lighting, viewing windows and interlocked access doors are provided for maintenance and press setting purposes. The measured sound level outside the enclosure under normal operating conditions will not exceed a peak reading of 85dBA.

Main (left): Tool space area of press utilising the industry standard tool change system.

Above (Top): Typical HMI screen image.

Above (Bottom Left): Sample rings produced on the Coinmaster 4™.

Above (Bottom Right): Siemens PLC based Human Machine Interface (HMI).

Below: Full front access to the Coinmaster 4™ facilitates tool changing and maintenance.



Technical Specification

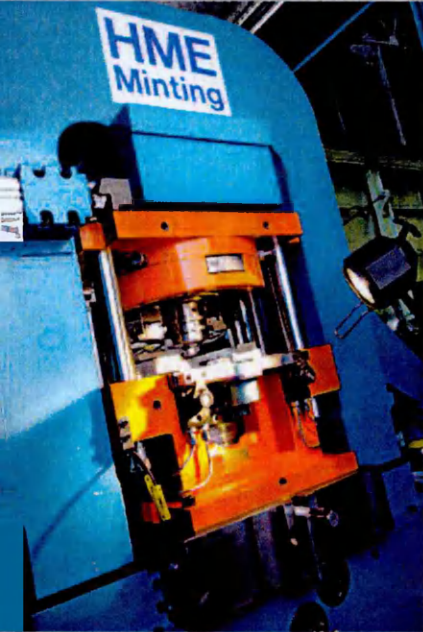

re: Front view of the optional HME fast Hydraulic Clamping System.

elow: Automatic Coin Blank Sorting Mechanism.

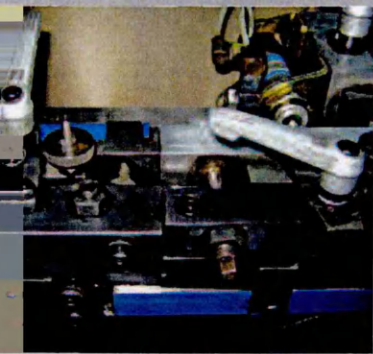

HME COINMASTER 4™ - HSC 160

Nominal Rating	1600 KN	
Maximum Coin Diameter	34 mm	
Maximum Coin Thickness	3.5 mm	
Stroke	8.5 mm	
Number of Strokes (Variable)	350 to 850 spm	
Crawl Speed	30 spm	
Tool Holder Adjustment	4 mm	
Ejector Force	30 KN	
Ejector Stroke	6.2 mm	
	Press	Press with Enclosure
Width	1770 mm	2080 mm
Depth	1870 mm	2210 mm
Height	2520 mm	2780 mm
Net Weight	9000 kgs	9400 kgs

KEY DESIGN FEATURES (CONT)

COINING FORCE ADJUSTMENT

A motorised wedge adjustment mechanism is incorporated into the upper tool holder. This adjustment is pushbutton controlled and can be operated whilst the press is in operation. Adjustment positions can be stored in the press control memory and recalled for automatic positioning of the upper coining tool.

OTHER OPTIONAL FEATURES INCLUDE

LOAD MEASUREMENT

Coinmaster 4™ can be supplied complete with a coining load measurement system. The system measures coining load at each press stroke, and can be used in conjunction with the Coining Force Adjustment to apply the optimum coining pressure to each coin blank.

RING PRODUCTION

Tool and tool holder packages are available for ring production. Bi-metal rings can be produced at normal press operating speeds. The outer ring and inner core are discharged separately.

HYDRAULIC TOOL CLAMPING

Fast hydraulic tool clamping can be offered improving the HME hydro-mechanical fail-safe facility. This system can also be retrofitted to all models of Coinmaster presses.

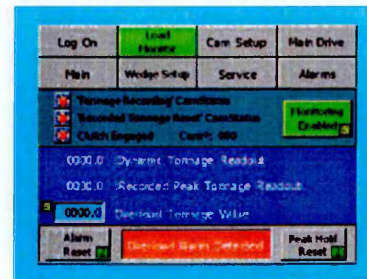

Load display monitor.

Highly Commended
"Best Metalforming Machine Tool"
MACH International Machine
Tool Awards



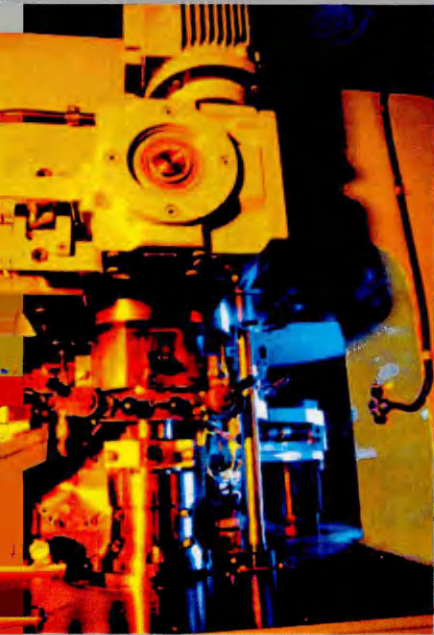

His Royal Highness, the Duke of Kent KG (left), inspects circulation coins produced on a HME Coinmaster 4™ Minting Press with HME Chairman, Ian Ridgway.

HME Minting

Belle Vue Wakefield WF1 5EQ England

Tel: +44 (0)1924 371161 Fax: +44 (0)1924 370928

E-mail: sales@grouprhodes.co.uk

www.hmeminting.co.uk

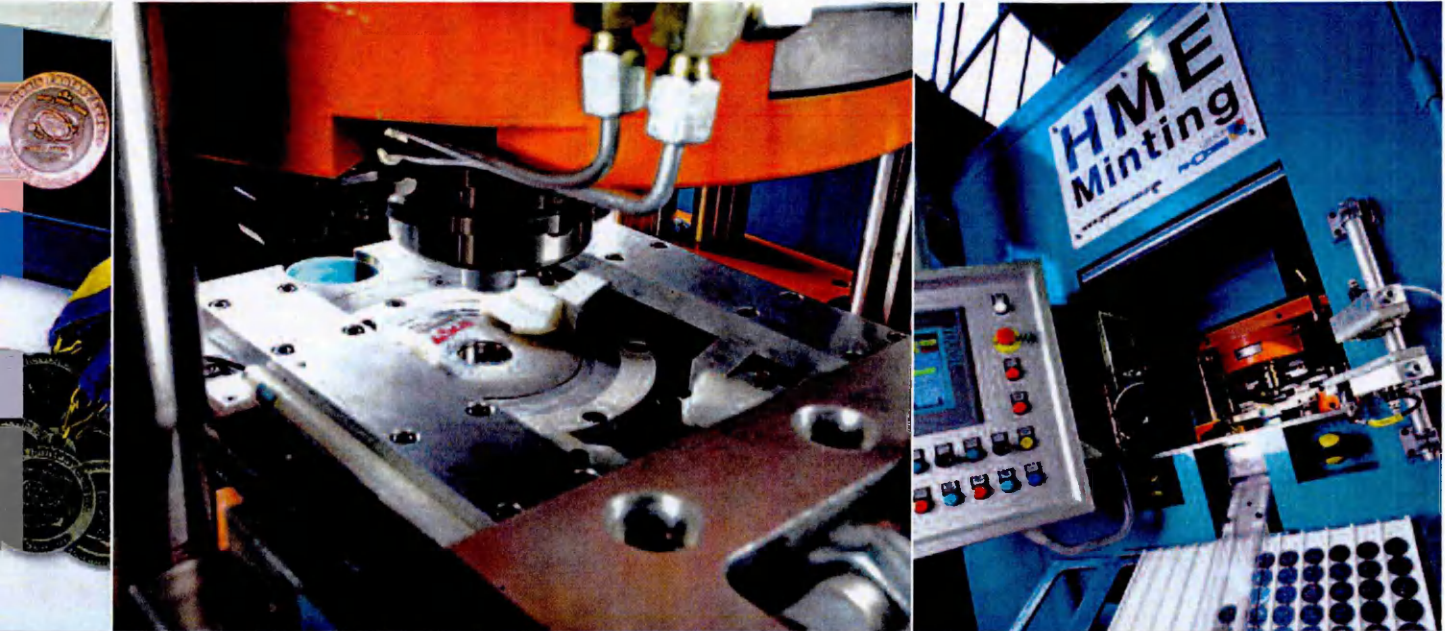

Special Purpose Machinery for the **Minting** Industry

HME K-Series
Coin and Medal Embossing Presses

HME
Minting

Our minting heritage

With over 250 machines installed worldwide, HME has offered unrivalled expertise in the supply of Minting Machinery. Today our presses produce precision engineered coins for leading Mints throughout the world.

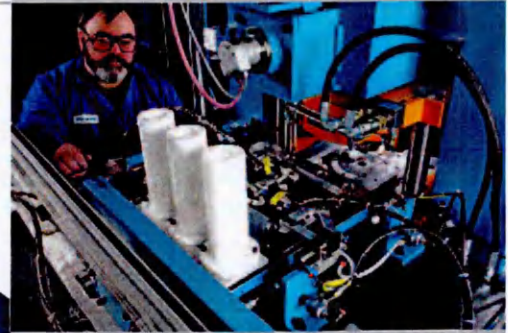
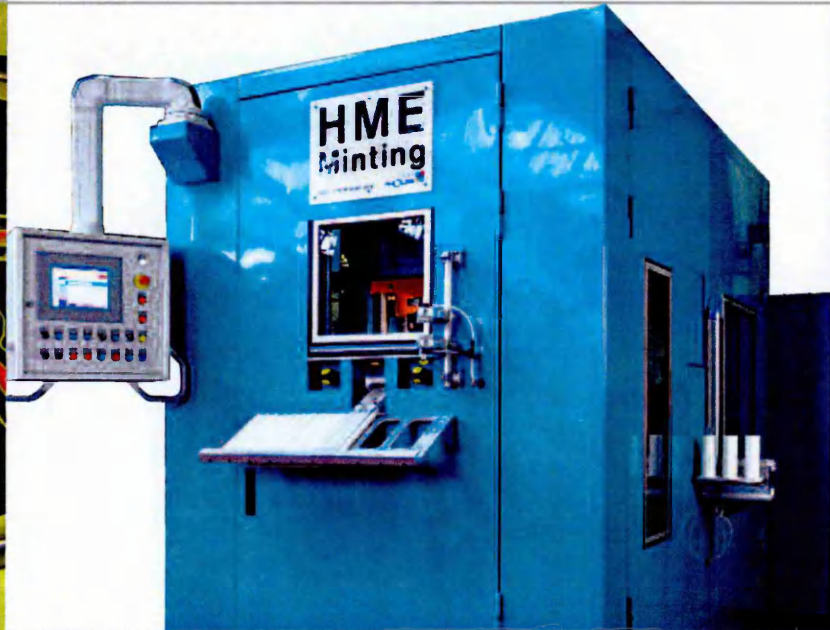

HME K-SERIES

The HME K-Series offers a market leading solution to a wide variety of coining, embossing, forming and sizing operations. The K-series Knuckle Joint Under-Driven Coining Machines are available in 180, 360 and 600 tonnes capacity, and are able to emboss a range of exotic materials, including Silver, Gold and Platinum.

The powerful coining action of the HME knuckle action drive combined with a choice of manual or fully automated feed systems makes these machines ideally suited for the production of medals and proof coins.

HME K-Series Minting machines are designed and built for quality, value and reliability. Compact frame construction minimises deflection through equal distribution of load, whilst pre-loaded linear bearings provide slide guidance promoting accurate die alignment. Pneumatic slide balancing, motorised top tool wedge adjustment and a multi-strike facility ensure a high degree of proof coin detail.

SERVICE AND SUPPORT

HME's design and manufacturing facilities enable the Company to offer a total service from initial concept through to site installation and commissioning. All major research and development work for the HME K-series range is conducted in-house and is supported by a well equipped Computer Aided Design Department covering mechanical, electrical, hydraulic and software engineering disciplines.

Main (left): HME K360 with acoustic enclosure.

Above (top): HME minting presses utilise a triple cartridge coin blank feed system to ensure optimum operation at continuous speeds.

Above (Bottom Left): Front view of the HME fast Hydraulic Tool Clamping system.

Above (bottom right): Press tool area with precision guided pillar die set.

SPECIFICATION

Maximum pressure (tonnes)

Maximum Stroke (mm)

Top Tool Adjustment (mm)

Speed (strokes per minute)

Main Motor (KW)

Net Weight (kg)

Key Design Features

HME takes particular pride in its ability to design and manufacture bespoke machinery and complete turnkey solutions. 'Special' minting presses can be manufactured to custom specification, and optional extras added where required.



- (right): Pendant mounted press control station for ease of operation.
- (top left): Typical touch screen HMI display.
- (top right): Bespoke HME automated indexing feeding system.
- (bottom): Proven design of the HME Minting Link Mechanism provides a short stroke and maintains positive control of the press slide over the entire cycle.

KEY DESIGN FEATURES OF THE HME K-SERIES INCLUDE:

KINEMATICS OPTIMISATION

Computer aided kinematics optimisation ensures that the modified harmonics of the press slide provide sufficient time for the blank material to flow, thus ensuring high quality precision coins are struck every time.

CONTROL TECHNOLOGY

Siemens touch screen Human Machine Interface (HMI), provides production and process information on all aspects of the press. The PLC control also includes a modem to enable on-line support.

TOOL HOLDER (COIN PRESS TOOLING)

Fast hydraulic tool clamping is offered as part of the HME hydro-mechanical fail-safe facility. Both top and bottom coining dies and collar are provided with quick release clamping systems to ensure minimum press downtime during tool changeover. The K-series also incorporates a programmable closed die multiple strike capability to produce high definition mirror finished coins.

MAIN DRIVE

The main drive is controlled via an AC Inverter providing infinitely variable speed settings, driving a balanced flywheel by means of a multi-groove belt. The flywheel rotates on anti-friction roller bearings and is supported on a quill rigidly attached to the press frame. A 'Crawl' mode is available for tool setting purposes.

AUTOMATED BLANK LOADING SYSTEM

HME minting presses utilise a triple cartridge coin blank feed system to ensure optimum operation at continuous speeds.

ISOLATING MOUNTS

Isolating mounts fitted to the press body reduce the vibration transferred into the foundations. This enables the machine to be installed on any floor providing it has the required load carrying capacity.

	K360	K600
	360	600
	60	100
	7	7
	40-80	35
	22	30
	10000	12200



Aerial photograph of the Company's 8 Acre Wakefield site.
Left: HME K360 undergoing final inspection prior to dispatch.



KEY DESIGN FEATURES (CONT):

BOTTOM EJECTOR

Fixed stroke hydraulic ejector with manual die height adjustment is fitted to suit different blank sizes.

LOW INERTIA CLUTCH AND BRAKE

High efficiency low inertia combined friction clutch & brake unit achieves immediate motion arrest.

LUBRICATION

Press lubrication is provided by a fully automatic re-circulating oil system complete with cooling circuit.

COINING FORCE ADJUSTMENT

Motorised wedge adjustment mechanism is incorporated into the upper tool holder. This adjustment is pushbutton controlled and can be operated whilst the press is in operation. Adjustment positions can be stored in the press control memory and recalled for automatic positioning of the upper coining tool.

LOAD MEASUREMENT

The HME K-Series can be supplied complete with a coining load measurement system. The system measures coining load at each press stroke, and can be used in conjunction with the coining force adjustment to apply the optimum coining pressure to each coin blank.

ACOUSTIC ENCLOSURE

HME acoustic enclosures are designed to reduce noise levels to below 80 dBA. Access doors and face ventilation are provided. All panels are removable to aid routine maintenance

GROUP RHODES
HME Minting is a member of Group Rhodes

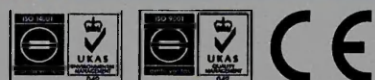

Data provided in this literature is an approximate guide and shall not be contractually binding. The policy of HME Minting is one of continuous product development. The right to change specification and design at any time without notice is reserved. 0.2/W/0411/A

Belle Vue, Wakefield, WF1 5EQ England
Tel: +44 (0)1924 371161 Fax: +44 (0)1924 370928
E-mail: sales@grouprhodes.co.uk
www.hmeminting.co.uk



THE QUEEN'S AWARDS
FOR ENTERPRISE:
INNOVATION
2010



Superplastic Forming and
Diffusion Bonding Presses

Special Purpose Machinery
For the **Aerospace** Industry



GROUP
RHODES

Press Manufacture

Aerospace and automotive design presents many fundamental metalforming problems. At Group Rhodes we are committed to first class, design led engineering solutions geared directly to addressing these technical needs.

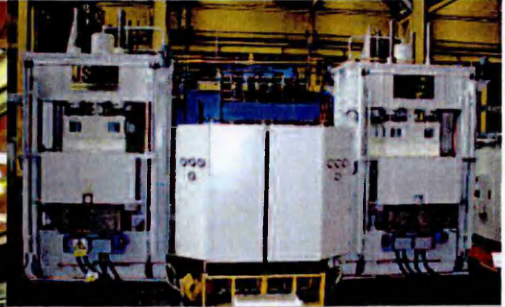
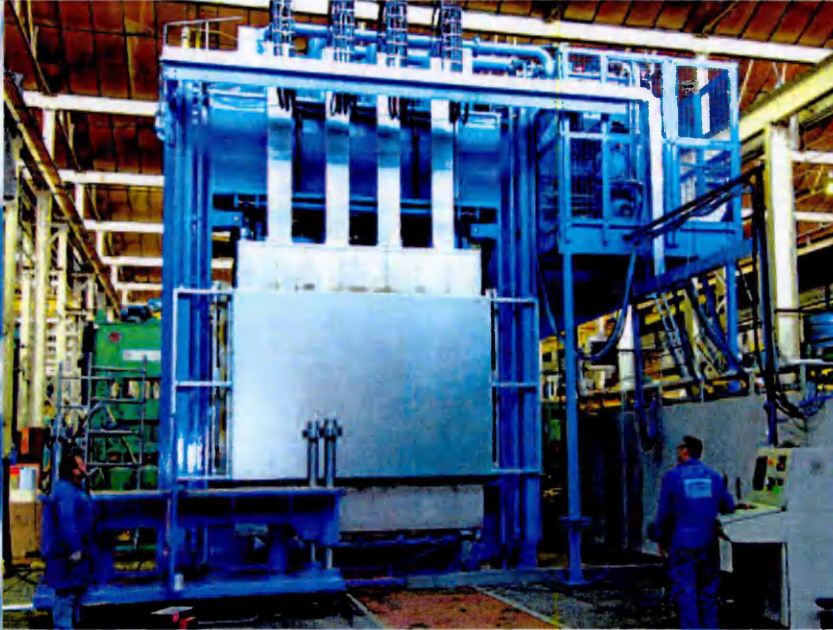

Group Rhodes (incorporating John Shaw and Chester Hydraulics) have continually been at the forefront of designing and manufacturing Superplastic Forming (SPF) and Diffusion bonding (DB) presses since the mid 1970's, a period when material analysts primarily in the aircraft industry were investigating the phenomena of superplasticity in Aluminium and Titanium alloys.

Today Group Rhodes is the only UK Company, and one of only a few operations in the World capable of developing commercially available automatic SPF/DB presses. International sales success demonstrates that the company continues to be at the forefront of the design and manufacture of this innovative technology.

RHODES SPF/DB PRESS INNOVATION & DESIGN FEATURES

THERMAL INSULATION

Group Rhodes has recently undertaken extensive research and development to improve the thermal insulation qualities of their SPF/DB presses, significantly reducing heat loss during the press cycle by up to 25%, (which in many cases could be up to 100 kW)

This reduction in thermal energy loss is as a direct result of Rhodes engineers working closely with ceramic specialists to obtain a material that is both mechanically strong yet thermally efficient. These new materials are now used in various forms to encapsulate the hot dies and components within the press hot zone.

METALLIC PLATENS

Platens are usually assembled from individual segments of high temperature alloy. By segmenting the platens, overall thermal expansion is greatly reduced and the segment interfaces are easily utilised for tool fixing. Metallic platens are ideal for use in a production workshop environment and a service life in excess of 10 years is not uncommon. Ceramic (Fused Silica) platens are also available as a cost-effective option.

Main (left): Cycle testing on a 1650 tonne aluminium SPF Press

Top: Two 150 tonne SPF/DB Presses undergoing final inspection prior to dispatch. In the background a 2000 tonne SPF/DB press with hot die loading system is under construction

Bottom: The Trent engine used on the A380 Airbus includes fan blades manufactured on SPF Presses

PRESS CONSTRUCTION

Group Rhodes offers a range of press products, power requirements, desired floor space.

SPF/DB presses are available as:

- Upstroke Presses
- Down-stroke Presses
- Pull-down Presses
- Four Column Presses

SPF/DB Design Features

Utilising state of the art technology perfected over many years of in-house research and development, Rhodes SPF/DB presses have been designed to provide accurate temperature control of press tooling (to within +/- 5 Deg C), accurate gas process forming control (to within +/- 0.15 Millibar) and accurate reaction load application control (to within +/- 2 Bar).

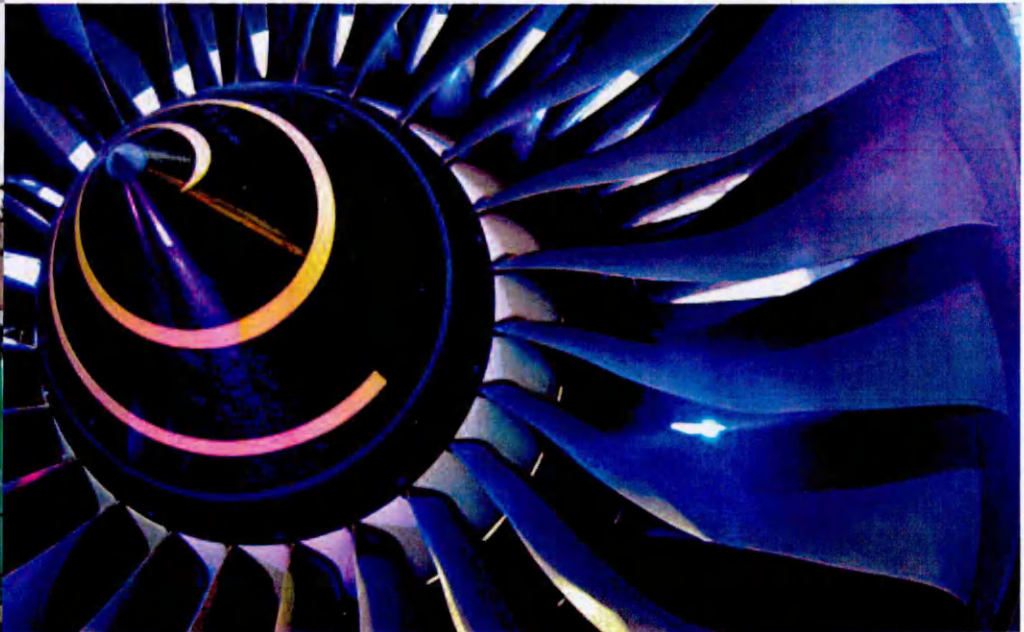

(right): Jet engine hollow wide chord fan blades

The exhaust bay doors for the F35 JSF are produced on a Rhodes SPF Press

(left): Twin modular 1650 tonne DB Presses

(right): 150 tonne SPF Press ready for dispatch

des to cater for specific forming techniques and available

- Single Frame Presses
- Multiple Frame Presses
- Shuttle Table Presses
- Modular Portal Frame Presses

SPF/DB DESIGN FEATURES (Continued)

ELECTRICAL RESISTANCE HEATING

Electrical Resistance Heating can take the form of single or multi zone cartridge type elements inserted into gun drilled holes in metallic platens, or alternatively can be a simple bare wire element laid in troughs or holes cast in ceramic platens. Multi zone cartridge elements (3 zones/cartridge element) achieve a very high degree of platen temperature control. As the platen temperature control zones can be easily balanced, there is no restriction to the size and shape of the process tooling, assuming it falls within the physical platen design parameters.

GAS FORMING CONTROL

Forming gas can be introduced from a single line for forming single sheet components using male or female dies or it can be fed via multiple control lines for forming sheet components. Group Rhodes Gas Management Systems offer complete control of multiple gas lines complete with purging, forming and vacuum facilities. Gas forming control can be achieved by one of two basic methods:-

Mass flowrate control

This method is usually used when forming enclosed capsular products where it is critical to know that internal forming is actually being achieved. The forming gas (Argon or compressed air) is introduced to the product in known volumetric quantities at predetermined pressures. Alternatively mass flow-rate meters can be utilised.

Pressure control

Forming gas is admitted to the product in an extremely accurate, controlled manner via servo controlled pressure regulators, having their own individual PID control loops.

ADVANCED ELECTRONIC CONTROL SYSTEMS

Group Rhodes control systems offer complete integration of heating, hydraulic, gas and machine functional control, together with on line and off line system monitoring.

HANDLING EQUIPMENT

Hot Die Changing Equipment

Hot Die Changing Equipment allows the safe removal and insertion of tools still at their elevated forming temperatures in single or multiple press layouts. The press is maintained at its forming temperature and production down time is reduced to an absolute minimum. A typical Handling System would incorporate a semi automatic tool charger complete with tool pre heat oven, cool down table and tool location table to form a complete operational facility.

Hot component loading Equipment

To eliminate the need for operators to be in close proximity with the hot die area during loading and unloading, Group Rhodes has developed various forms of semi automatic manipulators. Each system is custom designed to suit the particular product being formed.

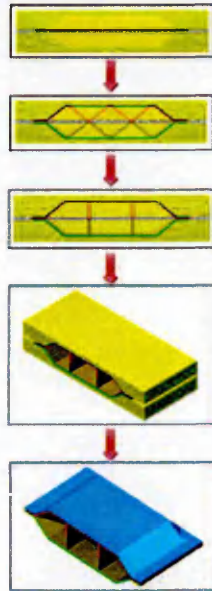
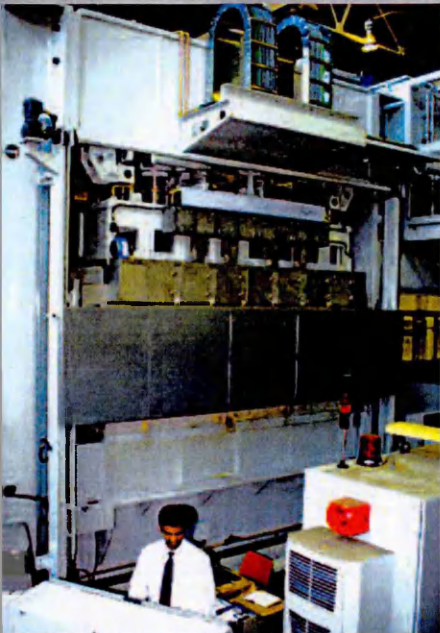

Left: 1200 tonne SPF Press undergoing final inspection prior to despatch

Centre: Multi sheet forming

Right: typical components manufactured on SPF presses include canard wings, jet engine fan blades and exhaust units.



The Art of Metalforming

The SPF/DB process offers freedom to produce more complex, stiffer, stronger and lighter structures in one piece thus giving improved component integrity. Efficient SPF/DB manufacturing techniques can create components that offer typical savings of 30% in cost and 20% in component weight.

SUPERPLASTIC FORMING

Superplastic Forming (SPF) offers engineers a method of accurately forming, single or multiple sheets of material into extremely complex, accurate, deep drawn shapes. The process involves heating the component sheet to a specific, accurately controlled, temperature and forming the sheet, or multiple sheets, into a mould cavity or over a male former by the application of controlled gas pressure. The process greatly reduces the formation of rippling, tearing and thickening of components, which usually occurs when they are cold formed.

DIFFUSION BONDING

Diffusion Bonding (DB) is a joining process achieved by the application of load at elevated temperatures. The resultant molecular bond offers a fully homogeneous joint, which, in many cases, is undetectable under microscopic examination.



300 Tonne SPF Press



Jet Engine Exhaust Manifolds



SPF Control System



Fan Casing



Data provided in this literature is an approximate guide and shall not be contractually binding. The policy of Group Rhodes is one of continuous product development. The right to change specification and design at any time without notice is reserved. 0.1M/0611/A

Belle Vue, Wakefield, WF1 5EQ, England
Tel: +44 (0) 1924 371161, Fax: +44 (0) 1924 370928
E-mail: sales@grouprhodes.co.uk
Website: www.grouprhodes.com

IMPROVED SAFETY

A new Safety Scotch Locking System for De-Hacking machinery has been designed by Craven Fawcett engineers to enable maintenance work to be undertaken in a safe manner. Installed at Istock Doblet Head, on a non-Craven Fawcett De-Hacker, Engineering Manager Kevin Tomlinson commented, "The Safety Scotch Lock has dramatically reduced the risk of potential accidents".

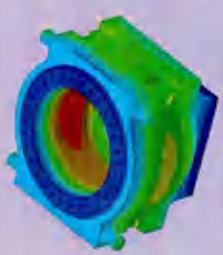

The latest 3D CAD and Finite Element Analysis technology is used in the design of new Craven Fawcett products.

The Craven Fawcett Safety Scotch Lock is a mechanical locking system, which uses rollers and a hydraulic cylinder to lift the De-Hacker Head off the chains. Cranes then lock into position to carry the weight of the Head, preventing it from falling. The permanent lock makes it safe to undertake the required maintenance work.

The Safety Scotch Lock can be further adapted to allow installation onto any CF or non-CF Setting Machine.

Service Engineers install European Equipment

Wienberger Ltd has chosen Craven Fawcett service engineers to project manage the installation of 'previously owned' capital equipment, which includes three box feeders, a crusher, a pan mill and a smooth roller mill.

Craven Fawcett design engineers produced the layout and foundation drawings required for the installation, and our service team will undertake the installation and commissioning work.

Service Manager, Gavin Richardson commented, "From first customers contact, through to the involvement of our design team, Wienberger have been kept informed of all project milestones. This process will continue throughout the installation of the equipment in order to ensure a successful project outcome."



Craven Fawcett service engineers ensure European customers are always covered.

INTERNATIONAL NEWS...

OUR MAN IN MALAYSIA!

We are currently in the final stages of agreeing a joint Venture Agreement with a Malaysian company to supply Craven Fawcett OEM parts to the Malaysian ceramic industry. Craven Fawcett has a successful history of supplying Clay Preparation machinery to the country, however a recent upturn in demand has warranted the need for a permanent presence in the country. The joint venture will allow Craven Fawcett to better serve existing Malaysian customers, and help generate new business.

OTHER NEWS...

Craven Fawcett recently received a delegation from Russia, who are looking to modernize their existing Clay Preparation production process. Further international interest in Craven Fawcett products has also come from China, Nigeria, Algeria, South Africa, Egypt, and Botswana, with enquiries ranging from spare parts to full day preparation lines.



Craven Fawcett Sales Manager, Glynn Dixon, visits Malaysia to discuss the supply of new Clay Preparation machinery.

WE'VE GOT YOUR BACK!

Craven Fawcett parent company Group Rhoddes has experienced a third consecutive year of 25% growth in annual turnover. Sales Manager, Glynn Dixon commented, "The Company's strong financial situation helps Craven Fawcett finance turnkey plant projects which can often cost millions of pounds."

Current orders received by Group Rhoddes include, a 10,000 Tonne Flobble Die Press, a 2500 Tonne Passive Test Rig and three Super Plastic Forming Presses. Destined for a major aerospace manufacturer, the 10,000 Tonne Flobble Die Press is the largest of its kind in the world, and will be used to produce nacelles for aircraft engines.

The Super Plastic Forming (SPF) presses, which are to be supplied to the aerospace and automotive industries, utilise high temperatures, with relatively low gas pressures to form aluminium and titanium alloys into strong, complex yet lightweight structures.



Presses for the new Aston Martin, Morgan and Ford GT are manufactured on a Rhodes Super Plastic Forming Press.

© Aston Martin

Reduced Maintenance Cost

One of the UK's largest tile manufacturers recently took delivery of a pair of newly designed rotors for their Craven Fawcett High Speed Crusher, which is set to dramatically reduce maintenance costs and improve machine performance.

Designed, manufactured and installed by Craven Fawcett, the new rotor is covered by a hard wear-resistant plate for improved longevity, and features 'easy change' hardwearing crusher tips.

The Maintenance Manager for the customer commented, "The new rotor looks very promising; output for the crusher has increased to over 100 tonnes per hour."



The new Crusher rotor has been designed for increased production and reduced maintenance costs.

Invention and innovation have always been at the heart of Craven Fawcett products. The Company is currently working in conjunction with Huddersfield University on a number of projects involving new materials and processes to improve wear capabilities.

PUT THE SLEDGEHAMMER DOWN!



Craven Fawcett has designed a Vibration System to help alleviate the problem of 'sticking material' in rotary silo feeders. The system consists of an air operated vibratory arrangement mounted to the Silo walls that can be operated manually or linked to the operation of the plough unit. Two, three or four vibrators can be fitted to each Silo.

Several customers, including Hanson Plc (Howley Park) and Istock Brick Ltd (Tyrore) have already taken advantage of the system and are now enjoying the advantages of labour free operation. Like many Craven Fawcett developments, this system can also be adapted to fit non-Craven Fawcett machinery.

Improving safety is always a key aspect of new Craven Fawcett product developments.

5 BOX FEEDER SLAT CONVERSIONS

Craven Fawcett has received five orders for Box Feeder Slat conversions over recent months. Hearty Elliott, Istock and Hanson are amongst those who have recently upgraded their Box Feeders to the new, Track Plate System.

The new system utilises a chain link with sealed bearings, which minimises friction and do not require greasing. In addition, less power consumption and reduced wear and tear on the gearbox has ensured a significant saving in maintenance costs. A much tighter fit between plates has also resulted in an average reduction of 10% in material spillage in comparison to the conventional cast steel link design.

Hanson Wilneote, Works Manager Chris Purcell commented, "The new Track Plate system has significantly improved the operational efficiency of our day feed."



2021 Tonne Box Feeder System with DHI Trazon Track Plate System.

Take Control of Our Stock

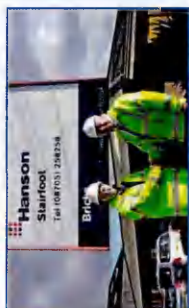

Hanson Stairfoot 141 (0870) 248234

Craven Fawcett, Wicky Bowring and Hanson Stairfoot, Factory Manager, Dave Mason, regular visits are undertaken to ensure the correct assignment stock is supplied.

Hanson Stairfoot: is the latest Clayworking factory to take advantage of the Craven Fawcett Consignment Stock Service (CSS). The Stairfoot factory is to pilot the scheme on behalf of the Hanson Heidelberg CEMENT Group.

The consignment stock will allow the Stairfoot factory to place high usage spare parts on their shelf at no additional cost, only paying for what is used, not for what is stocked. As well as an immediate reduction in invoice values, the CSS will allow Hanson Stairfoot to benefit from adjustable stock levels tailored to both meet production schedules and also ensure the elimination of unplanned down time. Factory Manager for Stairfoot, Dave Mason, commented, "The Craven Fawcett Consignment Stock will undoubtedly help the factory run more efficiently, improve cash flow and optimise our stock holding."

FREE CUTTING WIRES!

Manufactured in the UK, on a Craven Fawcett Wire Looping Machine, cutting wires have been brought back into the Craven Fawcett product range. To further show our confidence in the product, Craven Fawcett are currently offering FREE samples, to ensure customers are happy with design and durability of the wires prior to purchase.

'BEST MANUFACTURING SYSTEM' AWARD

The ability of the Group's design engineers has recently been recognised, by an international panel of judges. Winning the MACH award for Best Manufacturing System ahead of German and Japanese competition, the Company demonstrated its expertise at combining technology and innovation with cost effective design.

Craven Fawcett engineers project managed the system automation programming of the machine, which is now manufacturing quick fastening captive screws for the automotive industry.

The Craven Fawcett Range Of Machinery

Box Feeders • Worm Feeders • Crushers • Wet and Dry Grinding Mills • Mixers • Storage Hoppers • Extrusion Machines • Cutting Tables • Refractory Equipment • Vertical and Horizontal Pipe Machines • Pipe Trimming and Handling Equipment • Stiff Plastic Presses • Ancillary Equipment and Spare Parts for the Heavy Clay Industry.



Craven Fawcett cutting wires can be used on CF and non-CF crushing machinery.



Craven Fawcett

Special Purpose Machinery for the **Clayworking** Industry



Mechanical Brick Press

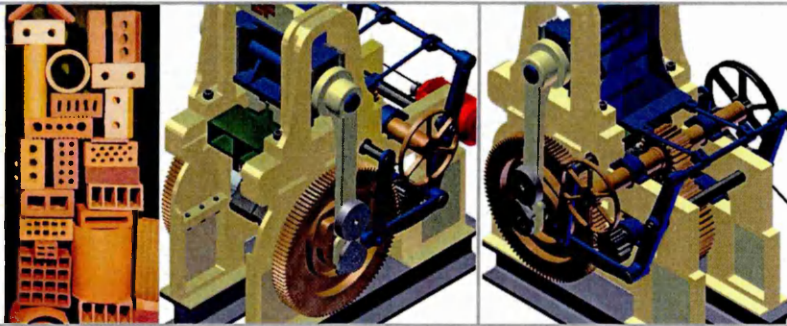

Craven Fawcett's Mechanical Brick Press offers:

- *A production rate of up to 1300 bricks per hour*
- *Re-pressed High Density Bricks*
- *A simple mechanical construction and operation ensuring ease of maintenance.*
- *Low energy requirements (5.5 kW).*
- *Portable, due to its relatively lightweight structure.*
- *Reduced noise levels, to provide a quieter environment for machine operators.*



Craven Fawcett is a member of Group Rhodes

SHAPING THE ELEMENTS FOR THE NEXT BUILDING GENERATION'

ADVANCED ENGINEERING FOR A GREENER FUTURE

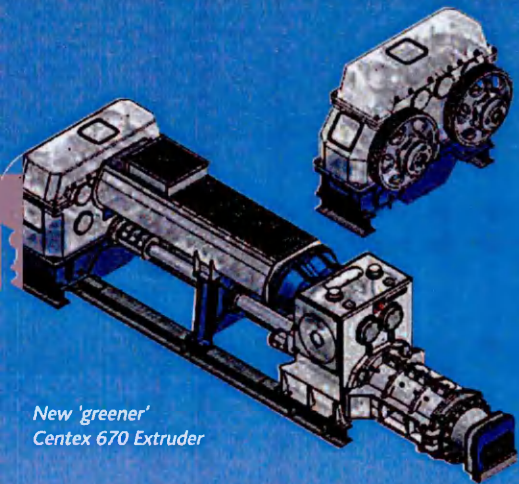

New 'greener'
Centex 670 Extruder

As part of the Company's strategic policy to develop 'greener' machinery, Craven Fawcett's new range of Centex and Centrim extruders have significantly increased the production of large format hollow blocks, but kept energy consumption constant. The innovative new design will allow the extrusion of multi-hollow blocks up to 6 units wide.

An expanded extrusion chamber, larger diameter worm sections, and a larger and longer barrel, are a few of the developments implemented on the new extruders. The machines also include independently driven packer shafts (previously driven by the main gearbox) which are used to pack the clay into the main extruder worm and avoid clay spillage.

The new layout results in more power being available to the main gearbox without increasing the motor size. The ability to vary the speed and power of each packer shaft also ensures much greater control of the clay and easier maintenance, all of which contribute to the machine operating more efficiently.

Further developments include a new 6-Point oil lubrication system implemented on the CF 90 Extruder. This upgrade has reduced the energy consumption of the machine and also improved the characteristics of the extruded product. Fitted to the end of the barrel, the new system ensures even lubrication around the clay to allow easier extrusion and minimises the problem of a 'pull-effect' should there be an air gap in the extruded material.

The positive nature of the new developments has been reflected in customer feedback and recent extruder sales in both Africa and Asia.

Another recent development project has involved one of the UK's largest tile manufacturers, who recently took delivery of a pair of newly designed rotors for their Craven Fawcett High Speed Crusher. The Company has since experienced dramatically reduced maintenance costs and improved machine performance. The rotor is covered by a hard wear-resistant plate for improved longevity, and features 'easy change' hardwearing crusher tips. The new rotor design has also allowed Craven Fawcett to further develop its range of high speed crushers, enabling the company to build much larger capacity machines, crushing up to 200 tonnes per hour.

Also included
in this issue:

Linear Plough improves
material throughput

Craven Fawcett
secures Saudi deal

D500 Disintegrator helps
in Bentonite Research

Benefits of
Refurbished Machinery

Queen's Award for
Enterprise: Innovation

Green Olympic Village:
Craven Fawcett's Managing Director,
Mark Ridgway, who is the UKTI's
Olympic Sector Champion for
Advanced Engineering, commented
"The Olympic Village (shown below)
aims to have the lowest carbon
footprint of any Olympic
stadium, hosting the
greenest games ever."

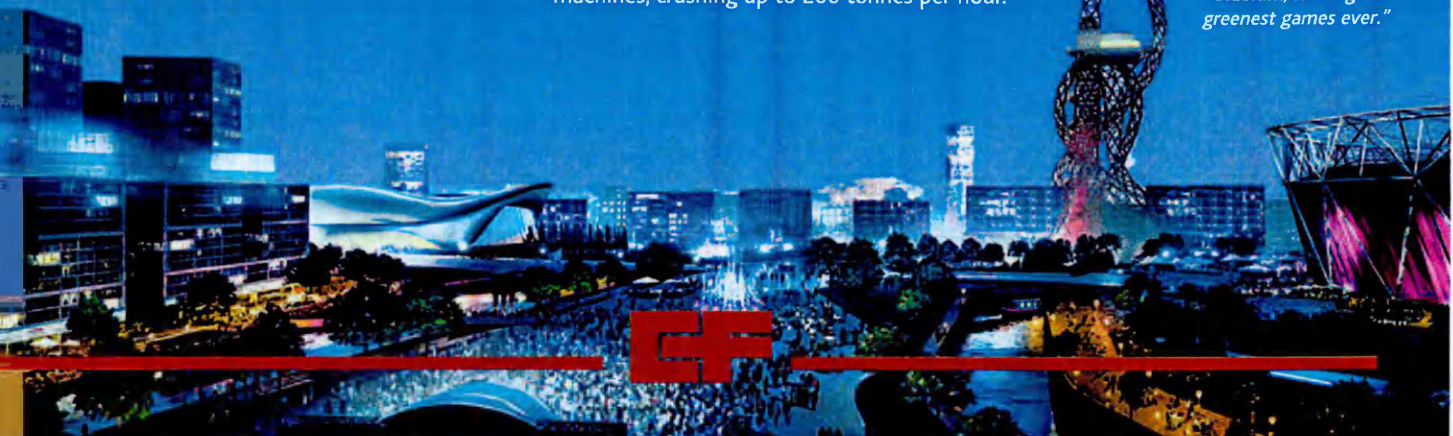

International Men of Engineering

Craven Fawcett Service Engineers recently installed and commissioned a Centrim 410 Extruder in Nigeria. Installed into a new production line, the extruder will be used to manufacture bricks, blocks and pavers.

The Nigerian Company are expanding production to cater for increased demand, and were delighted when the installation and commissioning was successfully completed to schedule. All relevant start-up and operation performance checks were undertaken to ensure the extruder was optimised for maximum throughput, and the Craven Fawcett engineers also ensured the smooth integration of the Centrim Extruder with the rest of the Customers clay preparation plant. This new Nigerian installation also included cutting and handling equipment, and in order to save cost, Craven Fawcett engineers designed a foundation drawing to reflect the existing infrastructure.



Craven Fawcett service engineers are based in the field to ensure a rapid response to customer requirements.

Taking comfort in the knowledge that Craven Fawcett engineers are always on hand to deal with issues ranging from standard servicing, replacement of machine parts and unforeseeable breakdowns, the Nigerian customer was confident that Craven Fawcett had the technical ability to undertake the project. The project was specified and negotiated over a ten month period, with Craven Fawcett's expertise in stiff extrusion being a critical factor in the Company being awarded the contract.

Equipment To Die For!

Craven Fawcett's relationship with Tecnofiliere has recently resulted in a major ancillary contract to supply 10 Dies and a Mouthpiece. Installed onto a Craven Fawcett Centrim 410 Extruder, the dies are proving very effective in producing a range of clay products, from bricks and blocks through to slip bricks.



The Tecnofiliere product range includes a wide selection of dies, lubrication systems and die washing machines.

As the official UK and Eire agent for Tecnofiliere s.r.l., Craven Fawcett work with experienced supply partners and apply their engineering expertise and product range to develop innovative solutions to the heavy clay working industry.

Situated in Modena Italy, Tecnofiliere s.r.l. manufacture bespoke custom made dies and associated ancillary equipment for hollow block and brick production. The Company is renowned for developing extruder dies that simplify and shorten the setting operation and thereby help to eliminate the disadvantages of conventional dies, such as lost production during die replacement.

New Design proves a sweeping success

Craven Fawcett has designed a new Linear Plough for its Rotary Silo Feeders to increase material throughput. Independently mounted, the linear plough unit extends close to the centre cone, thereby removing more material out of the Silo when compared to the conventional swing arm method. Further benefits of the new system include easier maintenance and fewer wearing parts, thereby reducing the 'whole-life-cost' of the unit.

Like many Craven Fawcett developments, this system can also be adapted to fit non-Craven Fawcett machinery. Istock Brick Limited (Throckley) has already taken advantage of the new equipment. After installing the system on a non-CF Silo, and experiencing the benefits of increased material throughput, they have since modified an additional two Silos to incorporate the new linear plough.



Increasing output and reducing operating costs are key aspects of any Craven Fawcett product developments.

Strategic Spares for CF and non-CF Machinery



The Stinger (Iii) CMM offers an Ultra-portable design. Weighing only 4.5 kg, the arm can be moved easily throughout a job site.

The recent manufacture and installation of a vertical shaft for a non-CF Wet Pan Mill at Northcot Brick, and the reconditioning and installation of a turning attachment for a Fine Roller Mill at Bovingdon Brick, are just two examples of Craven Fawcett's ability to design and manufacture strategic spares for a full range of non-CF machinery.

The Company continues to invest in new technology to enhance both its R&D and reverse engineering capabilities. Its latest purchase of equipment, a STINGER Iii(tm) portable Coordinate Measuring Machine (CMM), is ideally suited for inspection, measuring and reverse engineering challenges, with powerful features such as infinite rotation and, according to our design department, integrated counterbalance (sounds like an essential feature! -ed.)

From the design and purchase of materials, through to the machining and fitting of a component, the complete production of strategic spares is undertaken in-house to ensure correct design and exact fit, while keeping cost and lead times to a minimum.

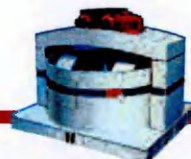

Record Machine Sales!

Craven Fawcett has achieved its highest recorded level of annual machine sales since the Company joined Group Rhodes in 2001. The sales which have been achieved during a difficult trading period, reflect a combination of innovative products and group financial strength.

"The industry has been hard hit by the recent economic downturn," said Craven Fawcett Sales Manager, Glynn Dixon, "yet over the past 24 months Craven Fawcett's financial stability has differentiated the Company and opened up new markets for our business".

As one of a few companies in the world capable of manufacturing a full range of clay preparation plant, Craven Fawcett machinery offers a solution to a wide range of production challenges world wide.

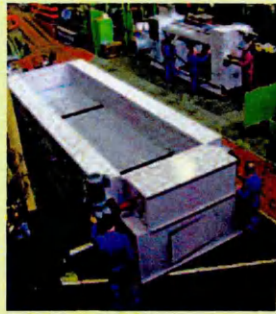

A Box Feeder and Centex 430 Extruder being assembled at the Wakefield site.

D500 Disintegrator to Help in Bentonite Research

One of the Middle East's leading research and development companies focussed on the applications of Bentonite, Egypt Nano Technologies, has purchased a Craven Fawcett D500 Disintegrator, to further its research into this versatile product.

Although utilised in an extensive range of sectors within the ceramic and building industry, Bentonite is mixed with clay and sand to form an adhesive.



The main frame of the D500 is of a fabricated steel construction, amply proportioned to keep vibration and deflection to a minimum.

The D500 order was won against strong international competition and offers a feed size of between 100-150 mm, and an output of 2mm depending upon the gap and bar settings. The machine consists of two independently driven rollers of different diameters between which the material passes. The large slow roll has a smooth renewable shell whereas the smaller, faster roll is fitted with renewable bars.

Craven Fawcett Secures Saudi Deal

Ceramic Pipes Company (CPC), based in Riyadh, Saudi Arabia, has taken delivery of 3 Craven Fawcett Vertical Pipe Machines.

Manufactured at the Company's Wakefield site and installed and commissioned by Craven Fawcett engineers, CPC purchased the 3 pipe machines to achieve an annual capacity of 100,000 tonnes of socketed clay pipes, ranging from 200 up to 800 mm diameter by 2 meters long. CPC was delighted with the on-time delivery of the machines and with the first unit in operation and the second awaiting commissioning, the Company is on schedule to achieve its target output.

Two of the machines are supplied with a hydraulic powered lift table that functions as a pipe support during the process of extrusion, and also with a complete set of dies for various diameter sizes of pipe. The extruders are equipped with vacuum pumps for a dense, robust pipe, and the control system allows for sequential automatic operation.

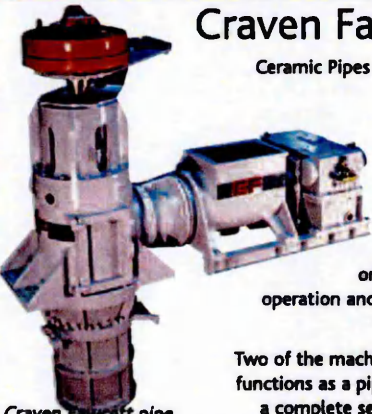

Craven Fawcett pipe machines are available with various auger sizes.

CF Flexibility Secures Machine Orders In Malaysia.

Over the past year, Craven Fawcett has supplied a new Centex 430 extruder, a reconditioned Centrim 410 extruder and a pre-owned PMT Extruder to customers in Malaysia. The sales indicate CF's flexibility and willingness to adapt to market requirements, a fact that has allowed Craven Fawcett to secure a position as one of the nations preferred suppliers of clayworking machinery.

All pre-owned machines are dispatched with CF's quality and reliability assurance, and are priced to suit a variety of budgets.

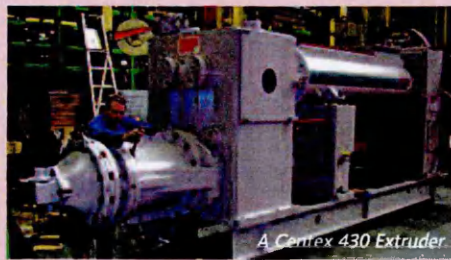

A Centex 430 Extruder

Refurbished Machinery

Arab Company, KEPCO, recently took delivery of a refurbished combined 17-21 De-Airing Extruder and Pug Sealer

One of the largest manufacturers of clay and concrete products in the Middle East, KEPCO (based in Egypt) has purchased a number of Craven Fawcett machines, which are used to produce clay pipes and pressed bricks. The heavy-duty 17-21 De-Airing Extruder and Pug Sealer will be used to extrude Refractory Bricks, Acid Resistant Bricks and Insulating Fire Bricks.

The decision to purchase the Craven Fawcett extruder was based on the machines excellent reputation for stiff extrusion of abrasive materials. The 17-inch diameter Extruder and Single Shafted Mixer/Pug Sealer is ideal for processing difficult clays, and will produce up to 18,000 perforated bricks or hollow blocks per hour. Encompassing a large De-Airing chamber with a single packer to reduce bridging, the extruder includes wear resistant augers of 28% chrome alloy and chrome mixer blades of variable pitch.

As part of the current heightened awareness of the benefits of machine rebuilds as a cost effective alternative to new machinery, Craven Fawcett has a proven ability to refurbish a full range of clay preparation plant, including equipment of other makes.



A Craven Fawcett 17-21 De-airing Extruder and Pug Sealer destined for Egypt.

The Craven Fawcett Range Of Machinery

- Box Feeders • Worm Feeders • Kibblers • Crushers • Wet and Dry Grinding Mills • Mixers • Storage Hoppers • Extrusion Machines
- Cutting Tables • Refractory Equipment • Vertical and Horizontal Pipe Machines • Pipe Trimming and Handling Equipment
- Stiff Plastic Presses • Ancillary Equipment and Spare Parts for the Heavy Clay Industry.

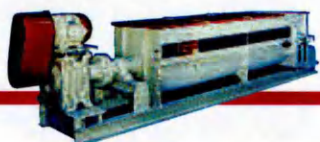

Queen's Award for Sister Company

Craven Fawcett's sister company, Joseph Rhodes received a Royal representative visit on 22 September when Dr Ingrid Roscoe, Lord-Lieutenant of West Yorkshire formally presented Joseph Rhodes (part of Group Rhodes) with a Queen's Award for Enterprise: Innovation at a ceremony attended by over 100 guests.

Made annually by HM The Queen, the awards are only given for the highest levels of excellence demonstrated in each category.



Managing Director, Mark Ridgway, receives the Queen's Award from Dr Ingrid Roscoe, Lord Lieutenant of West Yorkshire.



A Rhodes SPF/DB press destined for an automotive manufacturer to produce panels for the new Aston Martin, Morgan and Ford GT.

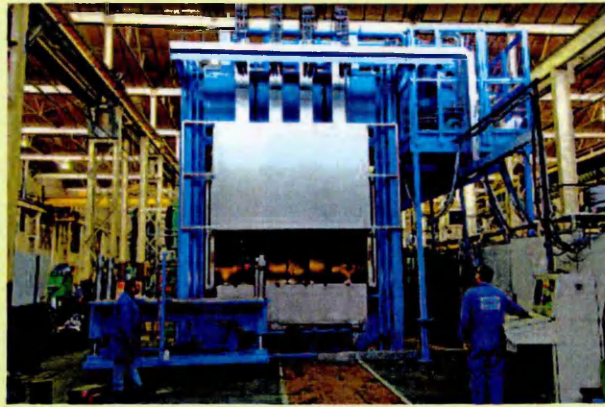

The Queen's Award was presented to Joseph Rhodes in recognition of its continuous development of Super Plastic Forming and Diffusion Bonding Presses (SPF/DB) specifically designed for the high temperature forming of titanium and aluminium alloys, primarily used in the aerospace and automotive industry.

The company's cutting edge skills have been recognised across the globe and its customers include BAE Systems and Rolls Royce.

Accepting the 2010 Queen's Award, Group Rhodes Managing Director Mark Ridgway said: "Winning this award for innovation is an incredible achievement for the business. In particular, it is a testimony to the dedication of our engineers and our innovative approach to product development throughout the group."

New Apprentices and Graduate Trainees



Rosie Baker
Secretarial Support
& Administration



Mark Shaw
Graduate
Accounts Trainee



Kumar Kandasamy
Graduate
Design Engineer



Siddharth Vadde
Graduate
Management Trainee



Jake Durham
Apprentice
Inspection Engineer



Jake Lawrence
Apprentice
Mechanical Engineer



Anthony Smith
Apprentice
Mechanical Fitter



Jermane Cockerill
Apprentice
Hydraulic Engineer

Richard Plantagenet, Duke of York

The Very Reverend George Nairn Briggs asked Craven Fawcett Chairman, Ian Ridgway, who has long standing ties with Wakefield Cathedral, if he would be kind enough to produce 12 plaques to commemorate the funeral journey of Richard Plantagenet, Duke of York.



Ian suggested ceramic plaques, which would make use of the Company's expertise in the clayworking industry and would also echo the materials available in the fifteenth century. Produced in association with Ibstock Brick, and donated to the Wakefield Historical Society, the plaques were presented to each church where vespers is sung on the commemorative pilgrimage from Pontefract to Fotheringhay.

CRAVEN FAWCETT LIMITED

Belle Vue, Wakefield, WF1 5EQ

Tel: +44 (0) 1924 375444 • Fax: +44 (0) 1924 290245

E-mail: sales@grouprhodes.co.uk • Internet: www.cravenfawcett.com



Appendix -3

JOSEPH RHODES - 3D DRAWINGS

SPECIFICATION

ONE SINGLE ACTING MAIN RAM = 1350 MM DIAMETER

TWO DOUBLE ACTING LIFT/RETURN RAMS = 250 X 180 MM DIA

MAXIMUM PRESSING CAPACITY = 10672 TONNE

MINIMUM PRESSING FORCE = 200 TONNE

MAXIMUM PAD PRESSURE = 454 BAR



10600 TON- RUBBER DIE PRESS
 2008 - BEST METAL FORMING/ FABRICATION
 MACHINE TOOL

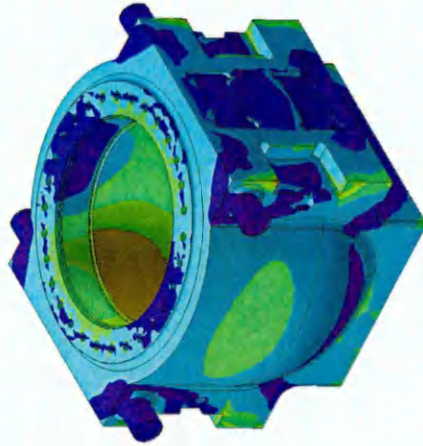

HYDRAULIC CYLINDER

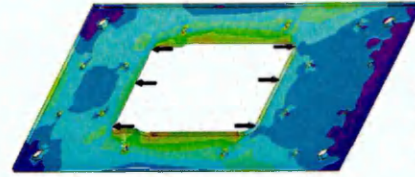

FRAME

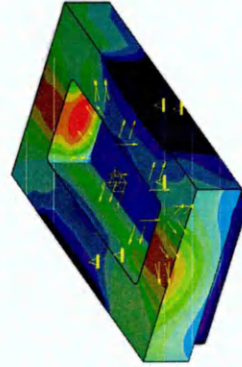

PAD HOLDER

STRESS ANALYSIS

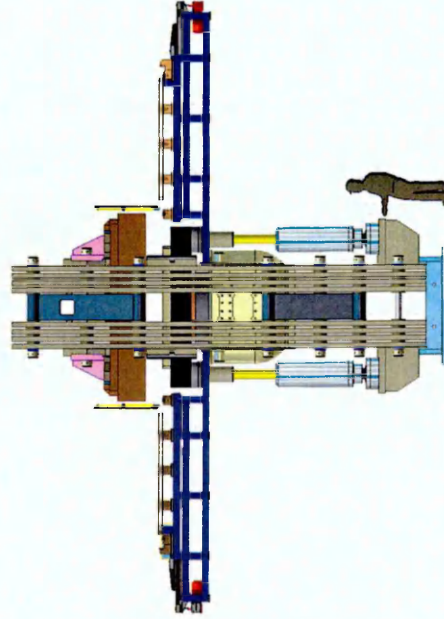
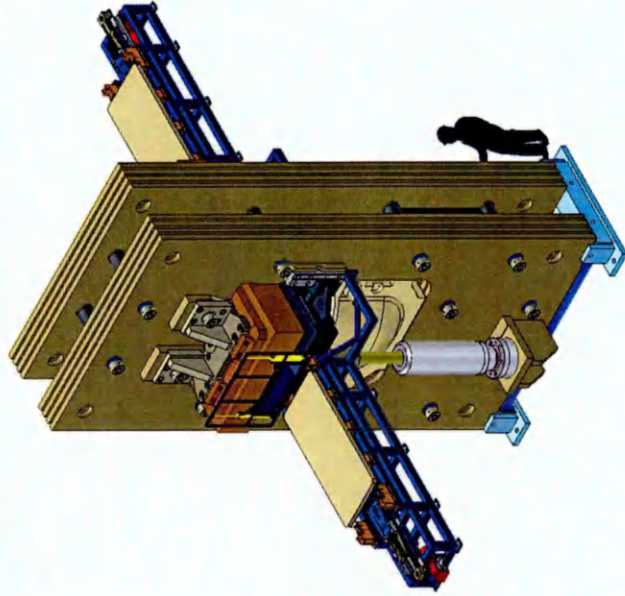

MAIN ASSEMBLY

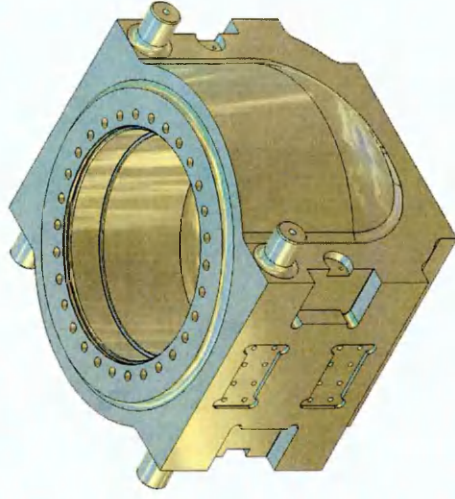

HYDRAULIC CYLINDER

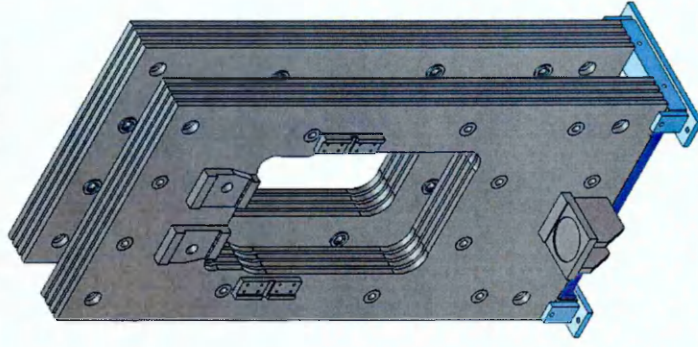

MAIN FRAME

SPECIFICATION

CONVENTIONAL HORIZONTAL IMPACT EXTRUSION MACHINE

PRESSING CAPACITY = 5 TO 1000 TONNES

APPLICATION : NONFERROUS RECYCLABLE TUBES - BATTERY CASES, TOOTHPASTE TUBES, COSMETIC, MAGCINE PHARMACEUTICAL TUBES AND AEROSOL CANS

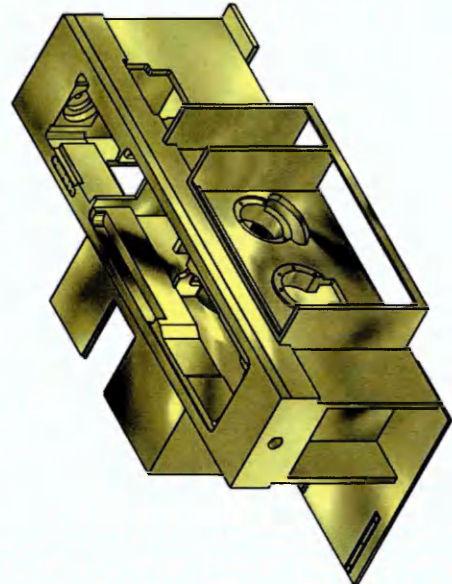

FRAME

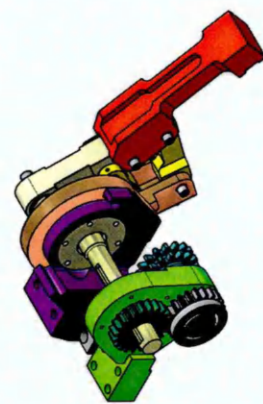

CAN-TAKE OF SYSTEM

KNUCKLE JOINT PRESS

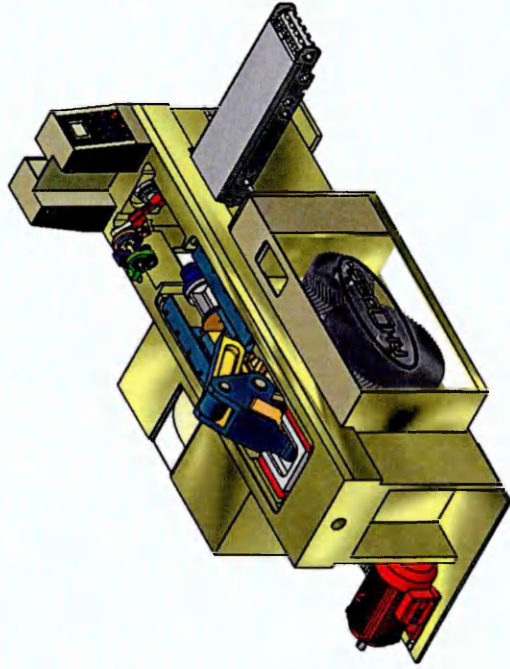

MAIN ASSEMBLY

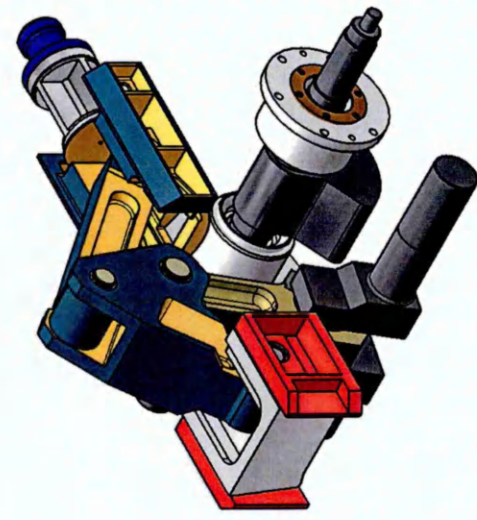

LINKAGE ASSEMBLY

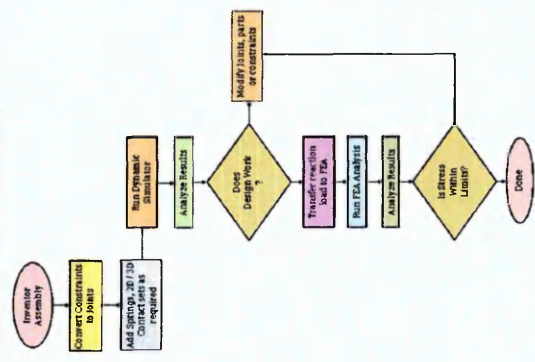

DYNAMIC SIMULATION

TOTAL INERTIAL FORCE - (DYNAMIC SIMULATION)

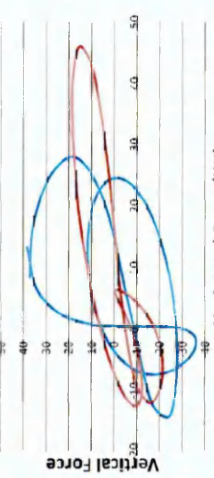

TOTAL INERTIAL FORCE - (THEORETICAL GRAPH)

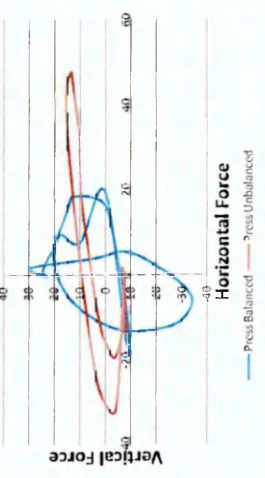

VECTOR GRAPH

SPECIFICATION

NEW GENERATION 160 TON HIGH SPEED COINING PRESS

CONVENTIONAL KNUCKLE JOINT LINKAGE ASSEMBLY

NUMBER OF COINS PER MINUTE = 750 - 1000

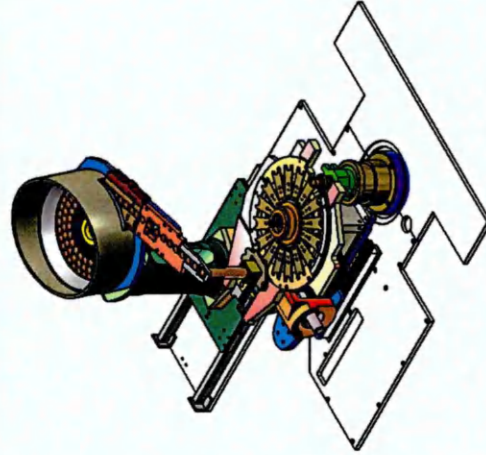
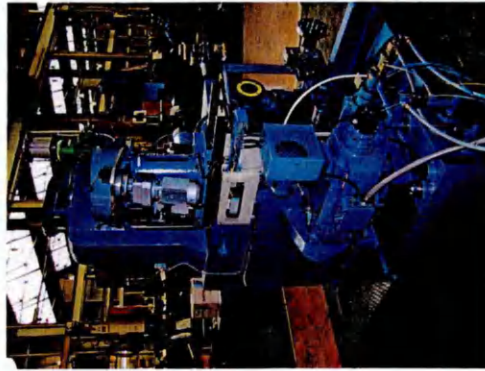

COIN FEEDER

HME COINMASTER IV

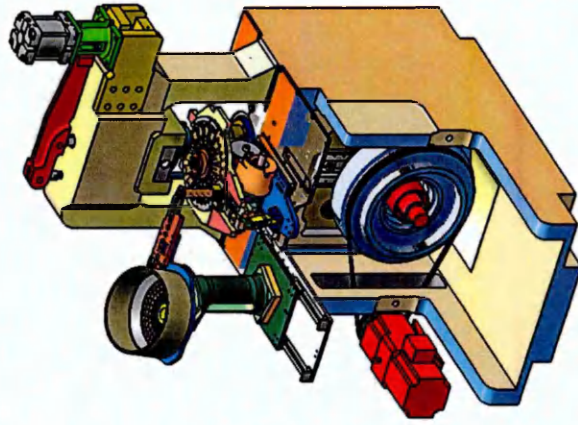

MAIN ASSEMBLY

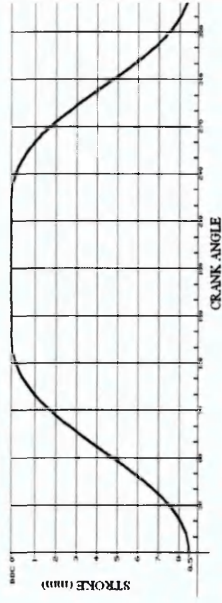
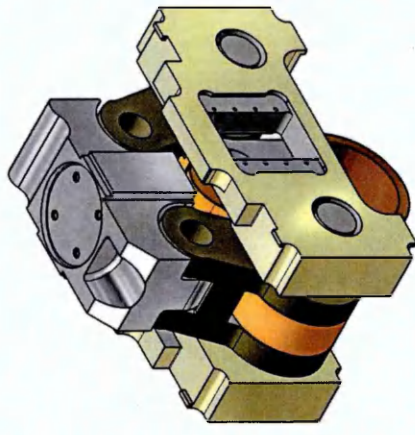
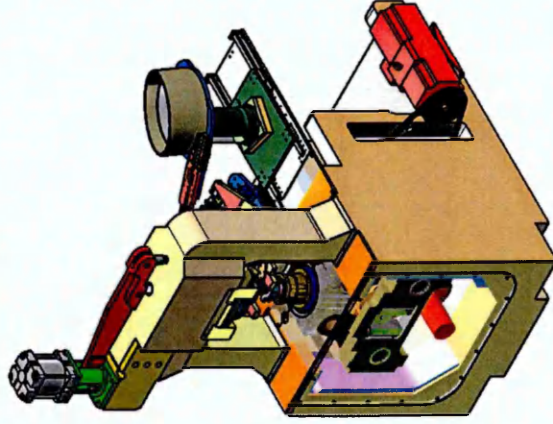

LINKAGE ASSEMBLY

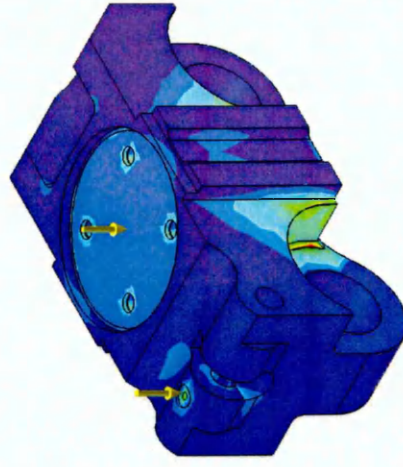

SLIDE-STRESS ANALYSIS

SPECIFICATION

1. APPLICATION: PRODUCTION OF SOLID OR PERFORATED BRICK OR HOLLOW BLOCKS
2. CAPACITY: UPTO 20,000 BRICKS / HOUR (70 TON)
3. DOUBLE SHAFTED MIXER = 3200 MM LONG X 1150 DIAMETER
4. LARGE DE-AIRING CHAMBER WITH TWIN PACKERS
5. BIGGER WORMS WITH 28% CHROME ALLOY METAL
6. LUBRICATED MOUTHPIECE WITH VALVE, GAUGE, PUMP AND OIL TANK
7. SEPARATE DRIVES FOR MIXER AND EXTRUDER VIA AIR OPERATED CLUTCHES

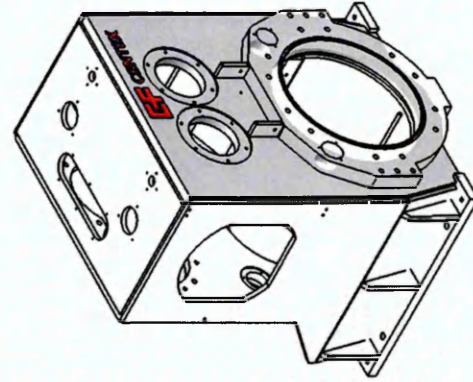

DE-AIRING CHAMBER

CRAVEN FAWCETT - CENTEX 430 EXTRUDER

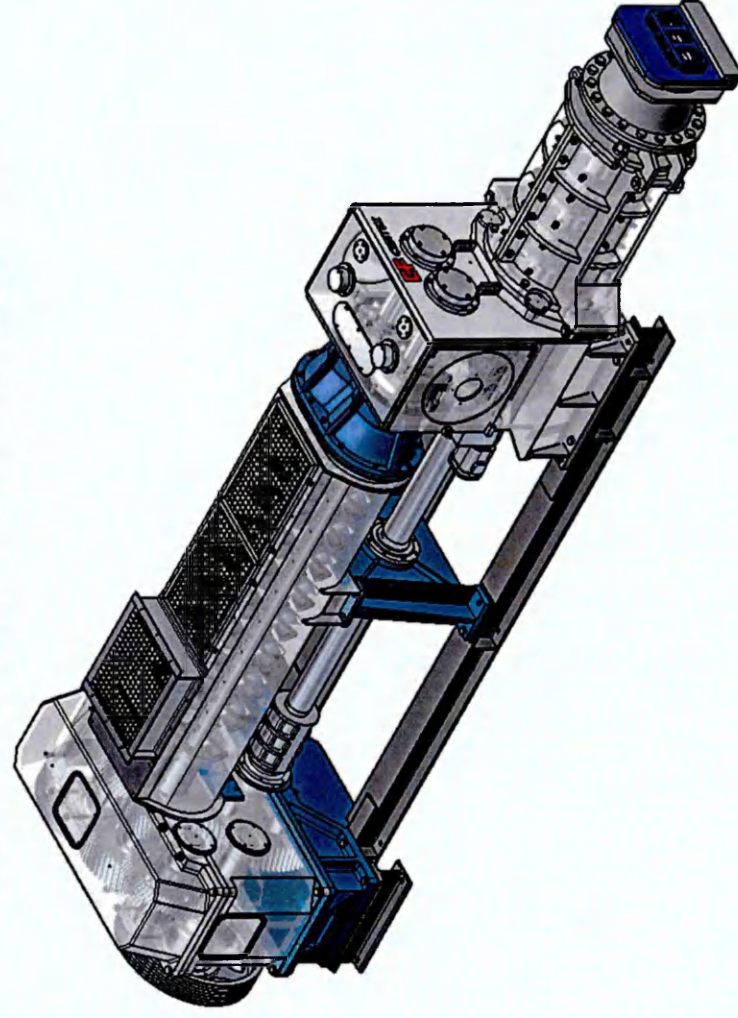

MAIN ASSEMBLY

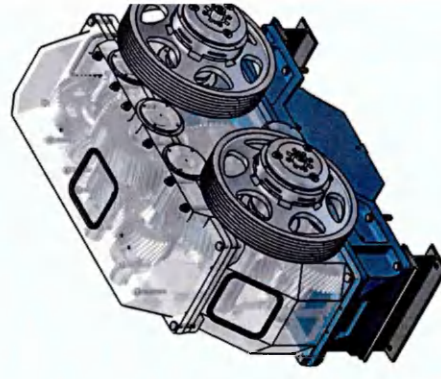

GEAR BOX ASSEMBLY

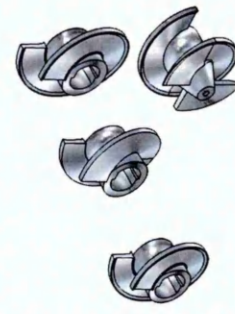

WORMS

10600 TON RUBBER DIE PRESS

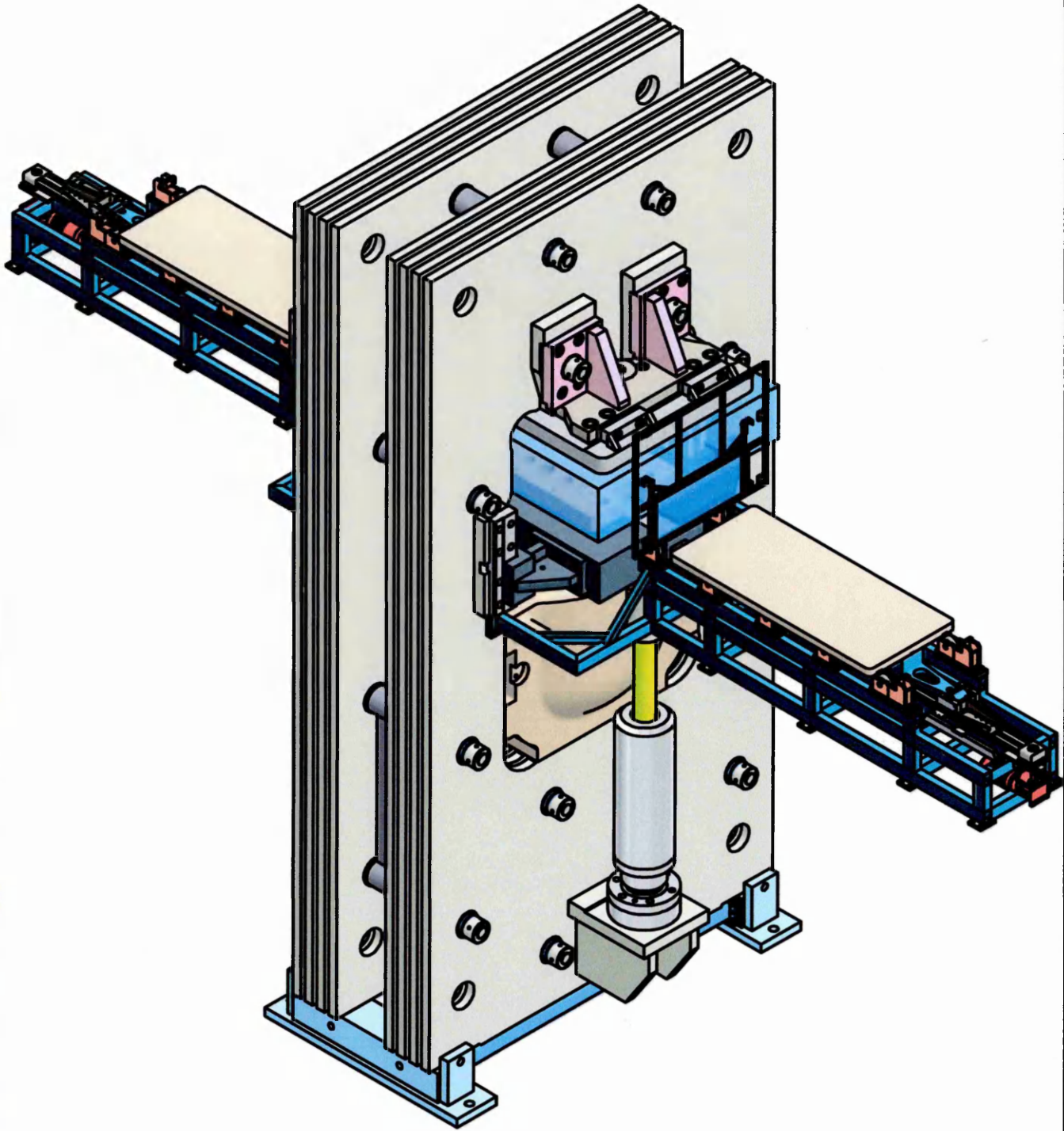

JOSEPH RHODES LTD, WAKEFIELD

10600 TON RUBBER DIE PRESS - HYDRAULIC CYLINDER

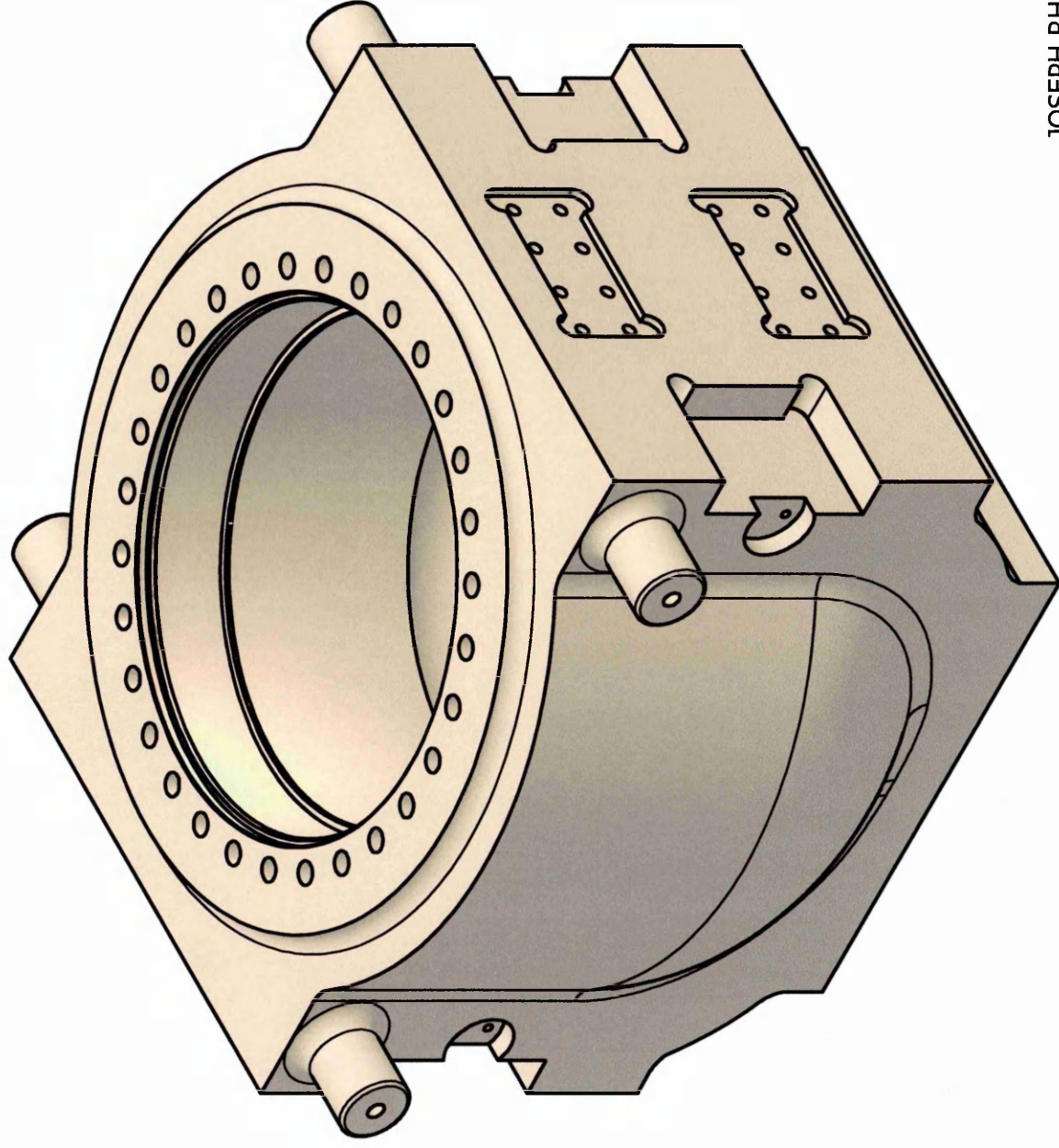

JOSEPH RHODES LTD, WAKEFIELD

KJ 35-HORIZONTAL IMPACT EXTRUSION ASSEMBLY

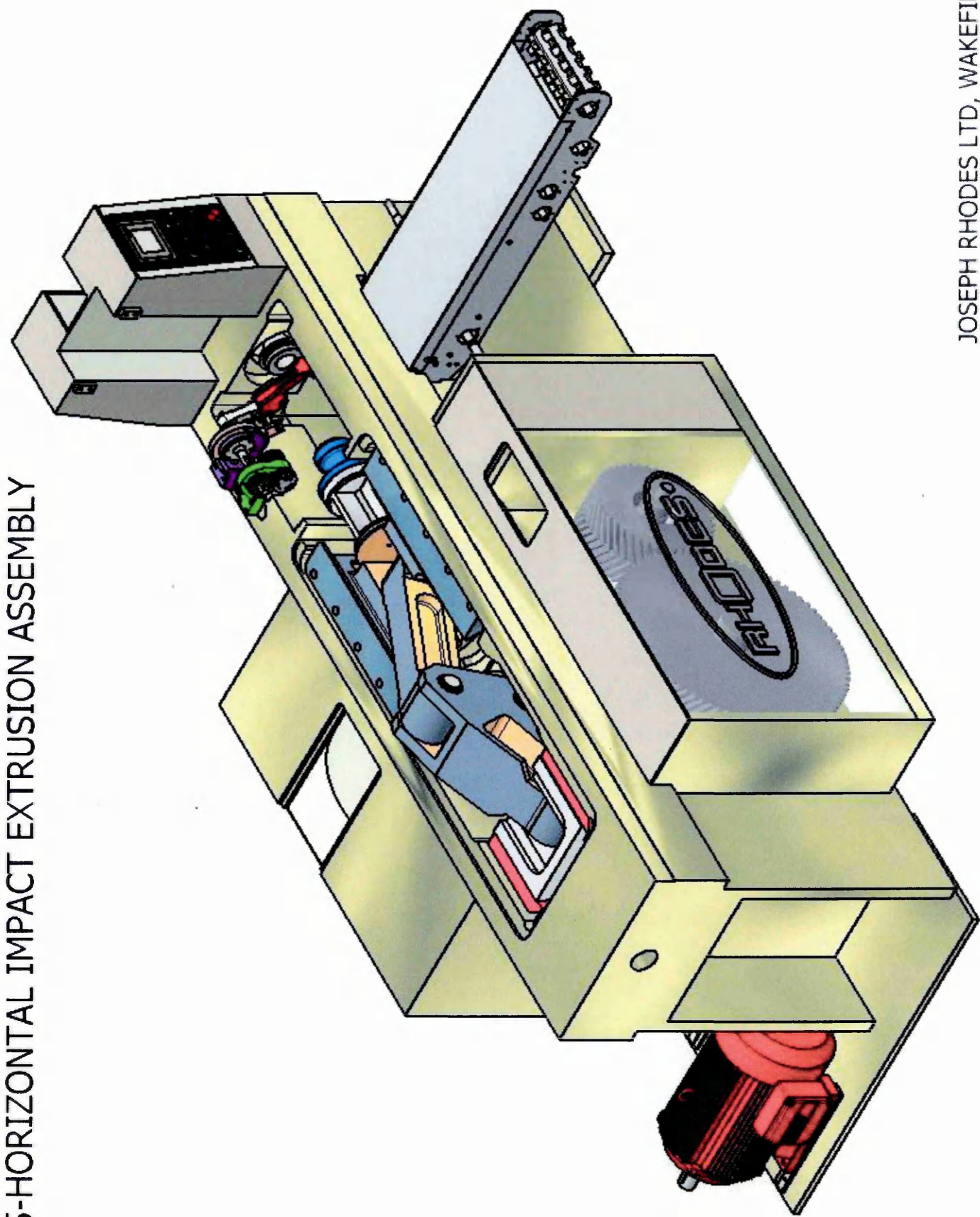

JOSEPH RHODES LTD, WAKEFIELD

HME COINMASTER

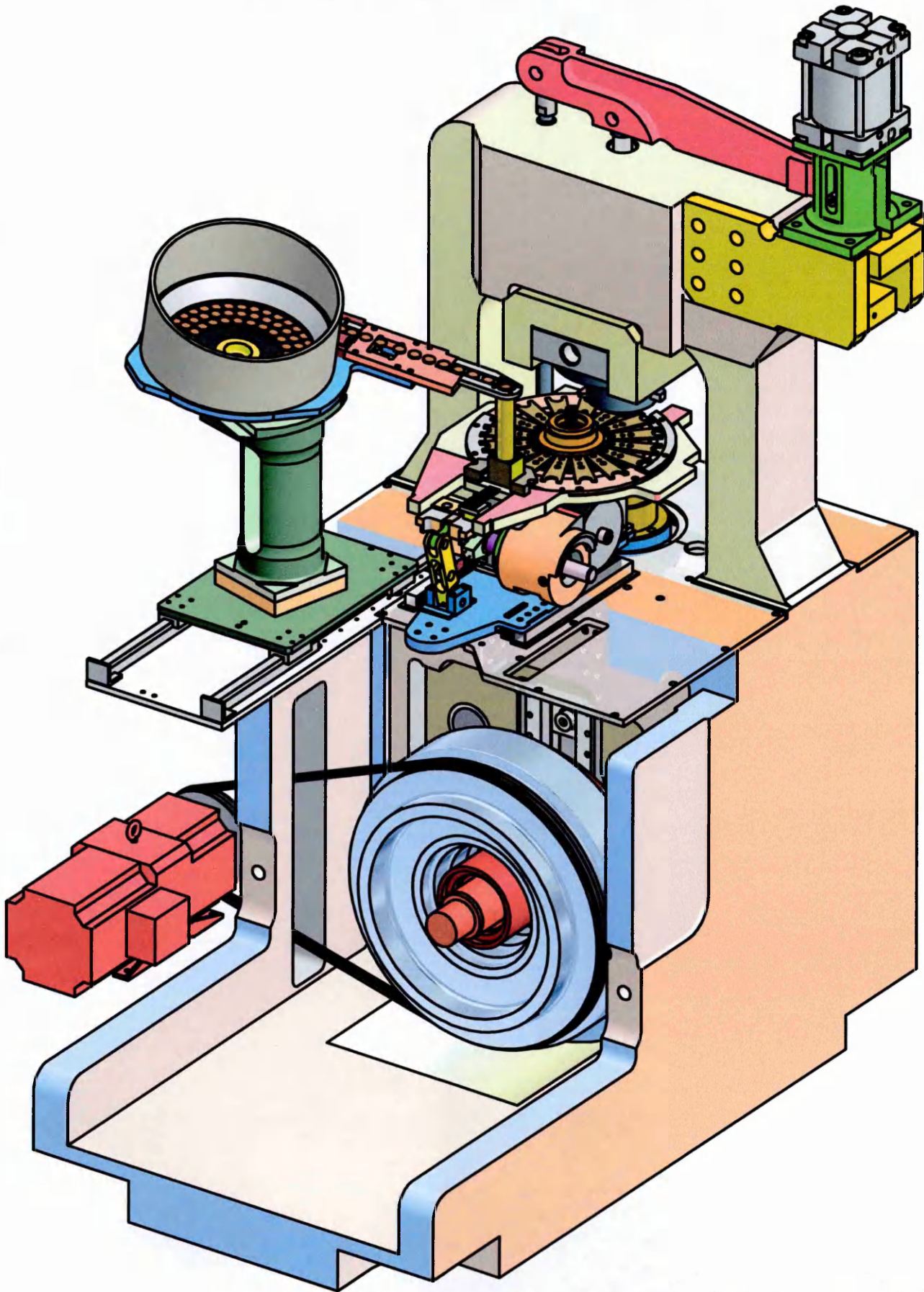

JOSEPH RHODES LTD, WAKEFIELD



HME COINMASTER

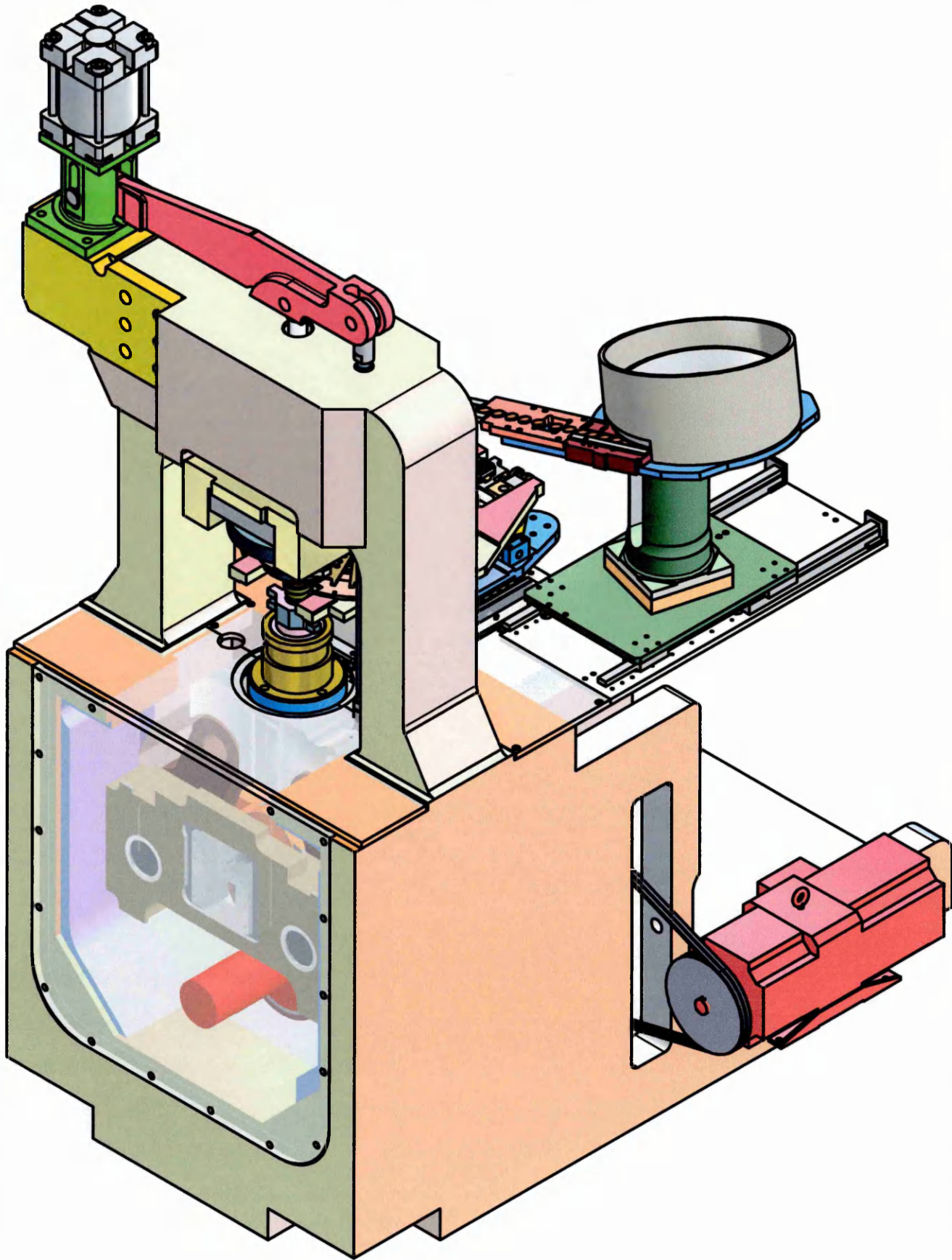

JOSEPH RHODES LTD, WAKEFIELD



LINKAGE ASSEMBLY - COIN MASTER

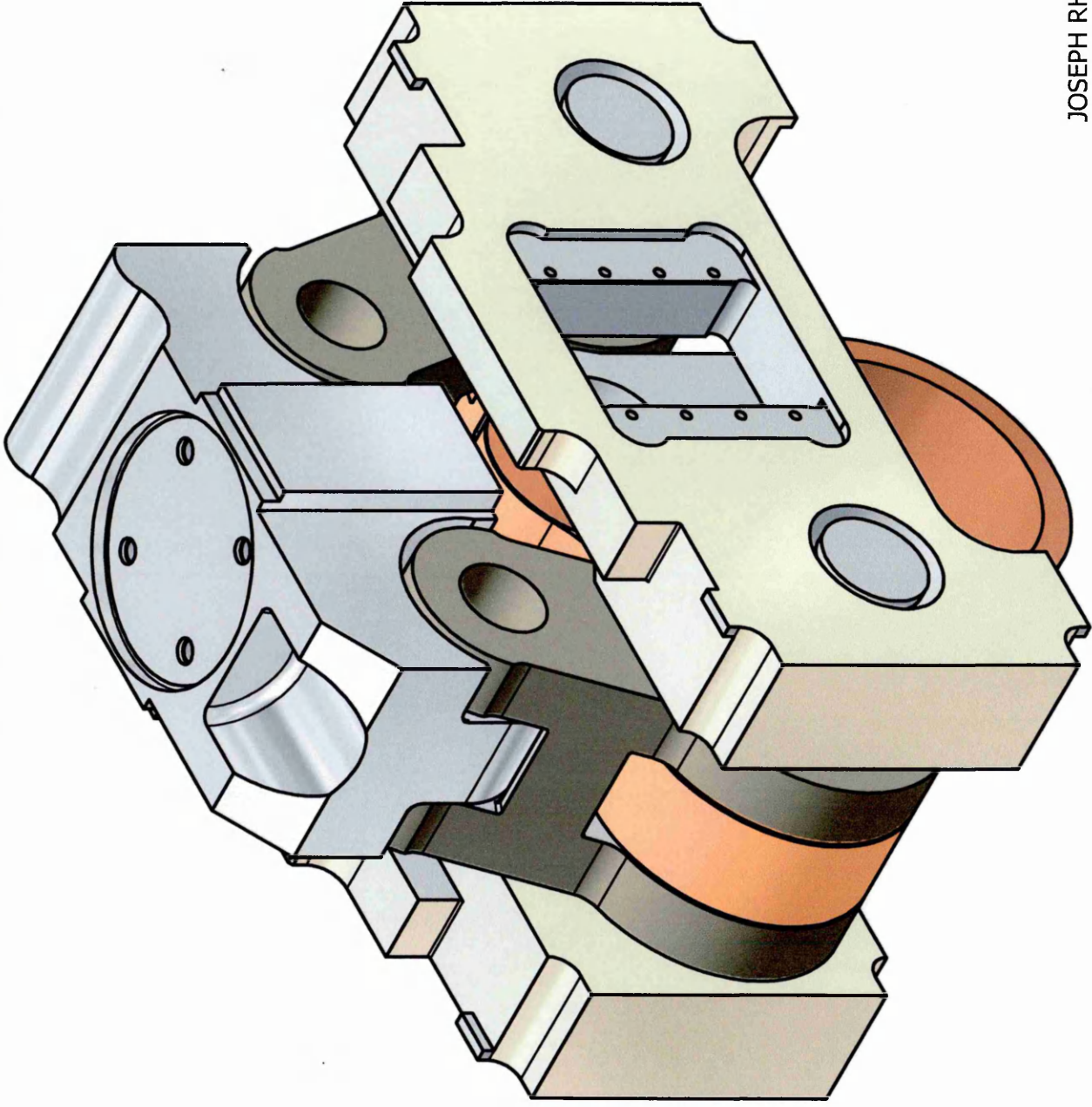

JOSEPH RHODES LTD, WAKEFIELD

CRAVEN FAWCETT - CENTEX 430

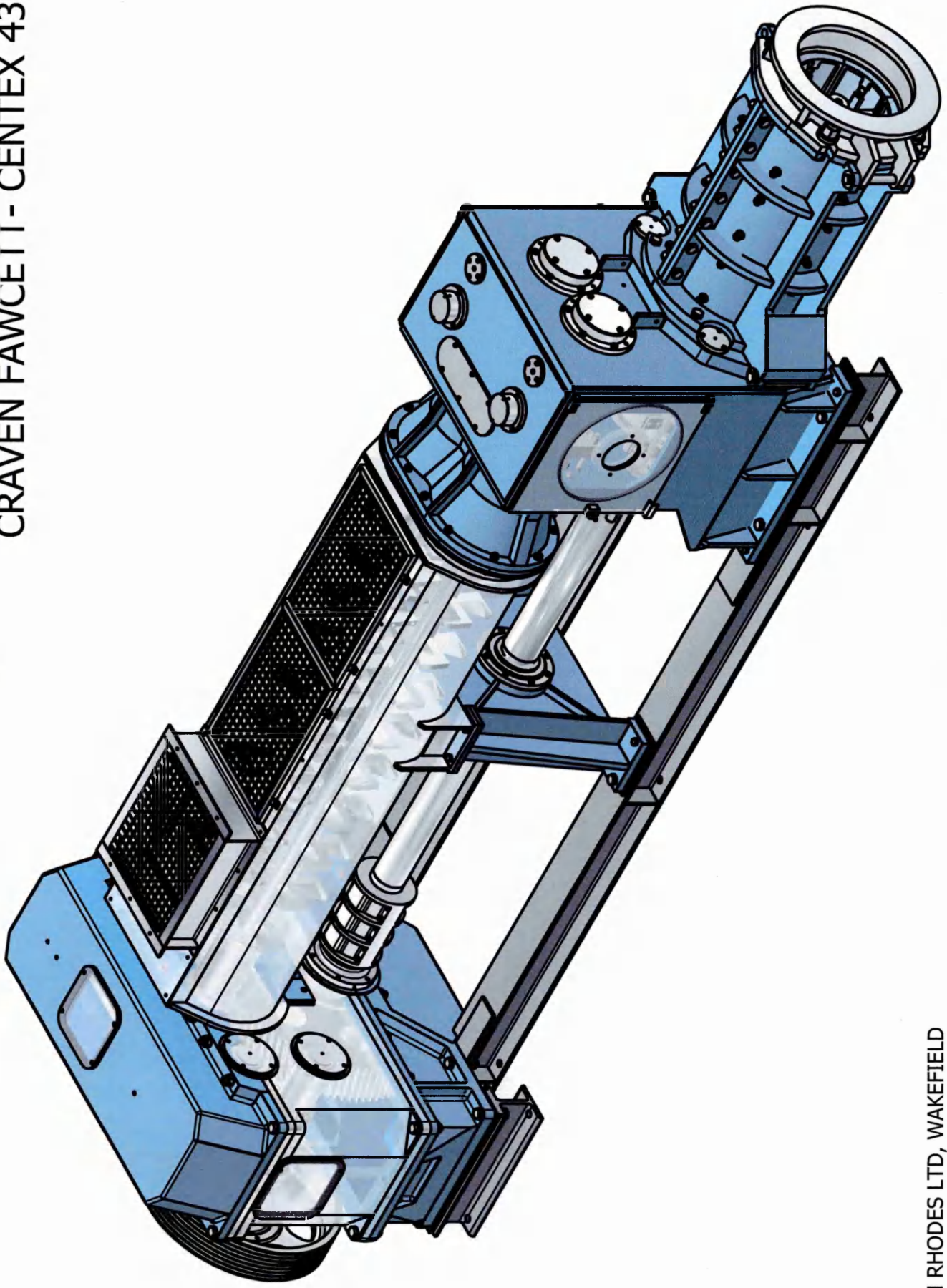

JOSEPH RHODES LTD, WAKEFIELD



DOUBLE BRICK REPRESS

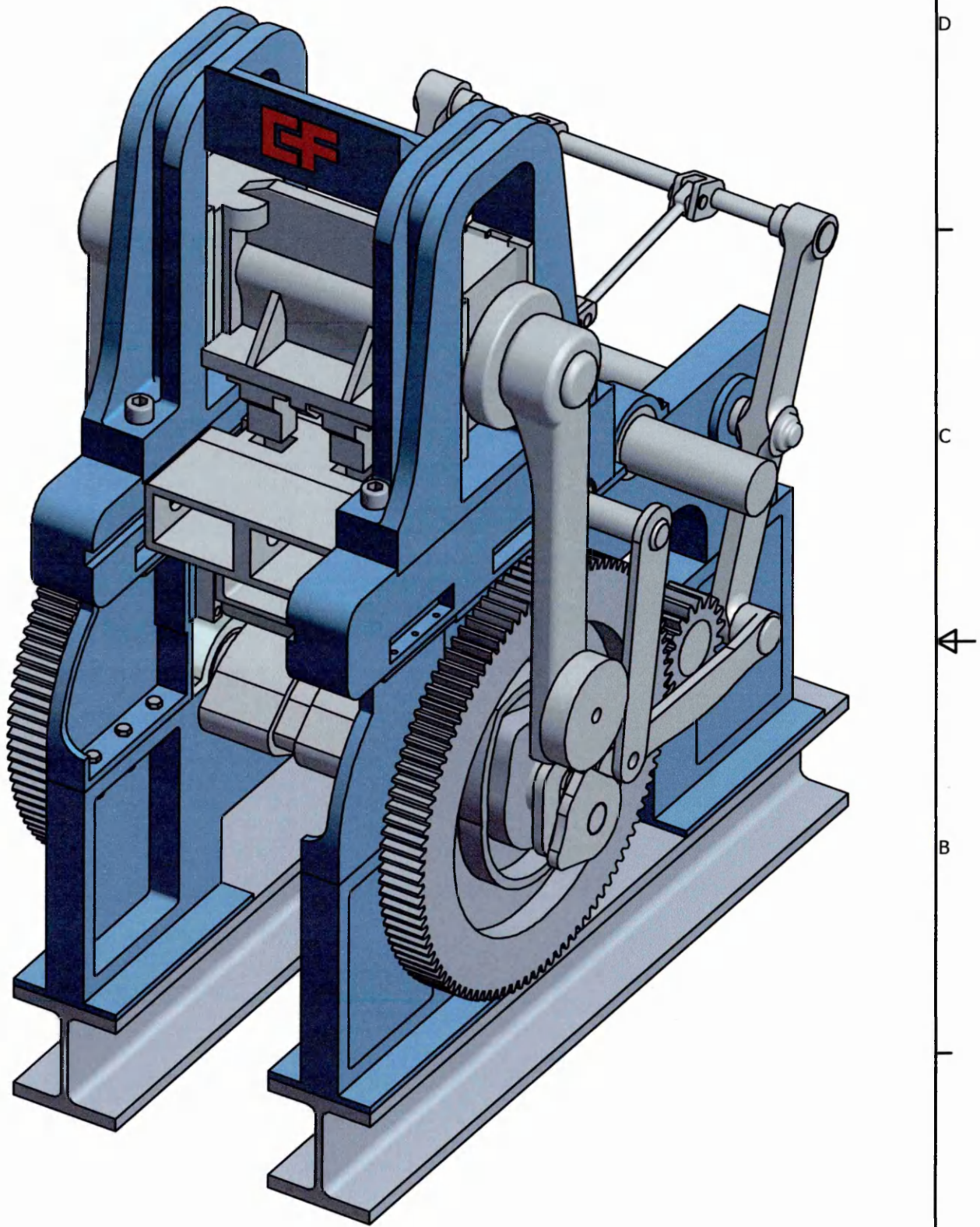

JOSEPH RHODES LTD, WAKEFIELD

Appendix - 4

JOSEPH RHODES - 3D ANIMATION DISC